

Ingersoll Rand

LIFTCHAIN® Air & Hydraulic Hoists



Contents

LIFTCHAIN® Air Chain Hoists 2

Available in hook, standard and low headroom trolley mount configurations, these hoists are ideal for hazardous or high duty cycle applications. Experience-proven features and safety enhancements include exclusive air gear motor, automatic fail-safe brakes, corrosion resistant load chain, spark resistant packages, overload protection and E-stops along with CE compliant packages.



LIFTCHAIN® Hydraulic Chain Hoists 13

Providing the exceptionally smooth and precise control that hydraulics offer the LCH series of hoists and trolleys are available in hook and standard or low headroom trolley configurations. Hydraulic motors and controls are particularly well suited for integration with complex programmable logic control (PLC) systems and other automated applications.



How To Order 22

Detailed model driver chart to direct you through the creation of the LIFTCHAIN® part number creation



Service & Accessories 23

Ingersoll Rand offers a full line of accessories and service solutions beginning with simple repair and maintenance kits and extending to complete on-site inspections, maintenance, and training provided by factory trained technicians anywhere in the world.



Solutions 32

Ingersoll Rand believes solutions begin with the specification of a product or service to meet your specific applications requirements and then continues through the products' entire lifecycle. We have over 100 years of experience in providing safe and cost effective lifting solutions.



Winch & Hoist Checklist 33

A comprehensive checklist to assist us in providing the best product or service to meet your applications specific requirements.



WARNING: Unless otherwise noted this equipment is not designed for transporting people or lifting loads over people. It is the user's responsibility to determine the suitability of this product for any particular use and to check compliance with applicable regulations. Before installation, see maintenance and operations manual for additional warnings and precautions.

LIFTCHAIN® Air Chain Hoists



Ingersoll Rand has over 40 years of experience in heavy load lifting applications in the most difficult and extreme environments around the world. The new range of LIFTCHAIN® LC2A series hoists incorporates the best of what we have learned over this time.

Featuring a compact, robust and modular design, the LIFTCHAIN® hoists offer a range of capacities from **1.5 to 100 metric tons** with a variety of configurations including hook mount or with plain, geared, or motorized trolleys for mounting on jibs or beams.

Experience drives features and options, and four decades of experience means we have plenty of both to choose from; Chain containers, CE approved models, cold weather designs, spark and corrosion resistant versions, 5:1 design factors, articulating trolleys, custom control systems, and low headroom models; the list goes on.

Whether it's lifting bags of farm produce or carefully positioning a 100 ton piece of equipment on a North Sea oil platform, we have the hoisting system to get the job done on time, every time, and at cost-effective price.

LIFTCHAIN® Air Hoist Series: 1.5 to 100 ton

Features and Options

LIFTCHAIN® Air Hoists Series Common Features

- **Rugged, Compact Design and Light Weight**
 - All steel construction for better durability. Particularly adapted for difficult environments.
 - Insensitive to dust and humidity
 - 100% duty cycle
- **Suitable for Hazardous Explosion Proof Environments**
 - Air motors (unlike electric motors) are inherently explosion proof
 - ATEX classification (as per directive EC 94/9/EEC)
 - Standard models are suitable for zone 2
 - Marking Ex II 3 GD c IIB 135°C X
 - Optional spark protection package for zone 1
 - Marking EX II 2 GD c IIB 135°C
- **Exclusive Gear Type Air Motor**
 - Better ability than other motors to accept contaminated air
 - High starting torque ensuring good spotting capability
 - Virtually maintenance free
 - Minimal moving parts
- **Automatic Multi Disc Brake**
 - Fully enclosed for better protection and corrosion resistance
 - No adjustment required. Maintenance free
 - Low pressure brake
 - "Venturi Effect" self-cleaning brake enclosure
- **Infinitely Variable Speed Control**
 - Precision spotting control with infinitely variable speed through pilot pendent control or pull chain control
- **Overload Protection Device (Available for non-CE models)**
 - Hoist is shut off and brake sets when overload of 125 – 130% is detected
 - Superior durability compared to mechanical slip clutch which wears and generates damaging heat
 - Prevents high forces being applied to the hoist and the customer support structure
- **Main Air Emergency Stop (Available for non-CE models)**
- **Upper and Lower Limit Switches**
 - Integrated in the hoist body for better protection
 - Allows the hoist to be also used in horizontal position
 - No adjustment required
- **Reduced Maintenance**
 - Innovative modular concept allowing easy inspections and maintenance for major components
- **Corrosion Resistant Load Chain**
 - Grade 80 calibrated load chain
 - Corrosion resistant treated for better protection and longer life
 - 5:1 design factor for safety and durability
- **Improved Exhaust Muffler**
 - Easy cleaning and simple replacement
- **Smart Design Bottom Blocks**
 - Bottom hook mounted on ball bearing for easier, smoother turning under load
 - Water drain hole to drain water from block
 - External lubrication point for better durability & ease of maintenance
- **Options and Accessories**
 - Plain, geared and motorized trolleys
 - Overload protection and E-stop (standard on CE models)
 - Chain containers (canvas or metal)
 - Marine paint systems
 - Spark resistant package for ATEX Zone 1
 - Rack & pinion trolley drive configuration
 - Low Temperature (-20°C) Certified (includes 3.1b material traceability certificates)
 - Air line accessories
 - Recoil festooning systems
 - Mining versions from 1.5 to 12 ton

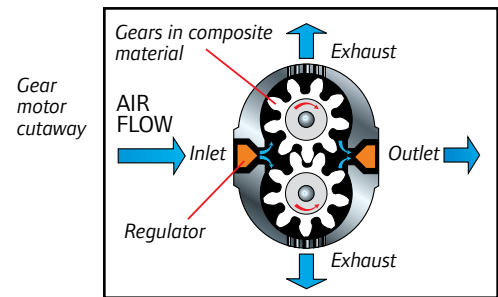

LIFTCHAIN® - Air: 1.5 to 100 ton

Hook Mount & Trolley Mount Specifications & Performance



Selection Guide - Air Chain Hoists

Model #	Capacity metric tons	# Falls	Motor HP	Lifting Speed @ Rated Load		Hook Mount Headroom		Trolley Mount Headroom	
				m/min	ft/min	mm	in	mm	in
LC2A015S	1.5	1	3.5	6.2	20.3	409	16.1	448	17.6
LC2A030D	3	2	3.5	3.0	9.8	549	21.6	592	23.3
New LC2A040S	4	1	5.5	3.9	12.8	580	22.8	590	23.2
New LC2A060S	6	1	5.5	2.2	7.2	717	28.2	730	28.7
New LC2A060Q	6	4	3.5	1.5	4.9	653	25.7	702	27.6
New LC2A080D	8	2	5.5	1.8	5.9	807	31.8	815	32.1
New LC2A120D	12	2	5.5	1.1	3.6	945	37.2	995	39.2
LC2A125S	12.5	1	10	3.2	10.5	865	34.1	1,000	39.4
New LC2A180T	18	3	5.5	0.7	2.3	1,063	41.9	1,195	47.0
New LC2A250Q	25	4	5.5	0.5	1.6	1,156	45.5	1,240	48.8
LC2A250D	25	2	10	1.5	4.9	1,235	48.6	990	39.0
LC2A375T	37.5	3	10	1.0	3.3	1,484	58.4	1,134	44.6
LC2A500Q	50	4	10	0.7	2.3	1,590	62.6	1,182	46.5
LCA750T	75	3	10	0.4	1.3	2,338	92.0	1,845	72.6
LCA1000Q	100	4	10	0.3	1.0	2,455	96.7	1,901	74.8

LIFTCHAIN® - Air: 1.5 to 100 ton

Specifications & Performance

Hook Mount - Performance at 6.3 bar - 90 psi ⁽¹⁾

Model #	Capacity metric		Minimum Headroom		Lifting Speed				Lowering Speed		Hoist Air Consumption @ Rated Load		Chain Weight (per mtr of lift)		Net Weight w/3m of Lift		Air Inlet	Sound Level ⁽²⁾	
	tons	#Falls	mm	in	Rated Load m/min	No Load ft/min	No Load m/min	ft/min	Rated Load m/min	ft/min	m ³ /min	ft ³ /min	Chain Size	kg	lbs	kg	lbs	BSP	dB(A)
LC2A015S	1.5	1	409	16.1	6.2	20.3	11.0	36.1	8.5	27.9	4	141	8x24	1.5	3.3	38	84	3/4	78
LC2A030D	3	2	549	21.6	3.0	9.8	5.5	18.0	4	13.1	4	141	8x24	3	6.6	48	106	3/4	78
LC2A040S	4	1	580	22.8	3.9	12.8	7.0	23.0	4.5	14.8	4.5	159	13x36	3.8	8.4	90	198	3/4	76
LC2A060S	6	1	717	28.2	2.2	7.2	3.6	11.8	2.7	8.9	5.2	184	16x45	5.7	12.5	125	275	3/4	79
LC2A060Q	6	4	653	25.7	1.5	4.9	2.5	8.2	2	6.6	4	141	8x24	6	13.2	74	163	3/4	78
LC2A080D	8	2	807	31.8	1.8	5.9	3.5	11.5	2.2	7.2	4.4	155	13x36	7.6	16.7	118	260	3/4	76
LC2A120D	12	2	945	37.2	1.1	3.6	1.8	5.9	1.3	4.3	5	177	16x45	11.4	25.1	170	374	3/4	79
LC2A125S	12.5	1	865	34.1	3.2	10.5	6.0	19.7	5	16.4	12	424	22x66	10.7	23.5	320	704	1-1/4	93
LC2A180T	18	3	1,063	41.9	0.7	2.3	1.2	3.9	0.9	3.0	5	177	16x45	17.1	37.6	277	609	3/4	79
LC2A250Q	25	4	1,156	45.5	0.5	1.6	0.9	3.0	0.6	2.0	5	177	16x45	23	50.6	324	713	3/4	79
LC2A250D	25	2	1,235	48.6	1.5	4.9	3.0	9.8	2.5	8.2	12	424	22x66	10.7	23.5	470	1,034	1-1/4	93
LC2A375T	37.5	3	1,484	58.4	1.0	3.3	2.0	6.6	1.7	5.6	12	424	22x66	10.7	23.5	820	1,804	1-1/4	93
LC2A500Q	50	4	1,590	62.6	0.7	2.3	1.5	4.9	1.2	3.9	12	424	22x66	10.7	23.5	920	2,024	1-1/4	93
LCA750T	75	3	2,338	92.0	0.4	1.3	0.7	2.3	0.7	2.3	12	424	32x90	24.5	53.9	1,700	3,740	1-1/4	93
LCA1000Q	100	4	2,455	96.7	0.3	1.0	0.5	1.6	0.5	1.6	12	424	32x90	24.5	53.9	2,200	4,840	1-1/4	93

(1) Working pressure from 5 to 7 bar (70 to 100 psi)

(2) Sound pressure levels are measured per European Standard EN 14492-2



LIFTCHAIN® - Air: 1.5 to 100 ton

Specifications & Performance - Standard Headroom ⁽¹⁾

Trolley Mount - Performance at 6.3 bar - 90 psi ⁽²⁾

Model #	Trolley Type	Capacity metric tons	Minimum Headroom		Trolley Speed @ Rated Load ⁽³⁾		Trolley Air Consumption @ Rated Load		Trolley Flange Adjustment		Minimum Curve Radius		Air Inlet BSP	Net Weight w/3m of Lift	
			mm	in	m/min	ft/min	m ³ /min	ft ³ /min	mm	in	m	ft		kg	lbs
LC2A015S	Plain	1.5	448	17.6	-	-	-	-	80-200*	3.1-7.9	1	3.3	-	90	198
LC2A015S	Geared	1.5	448	17.6	-	-	-	-	80-200*	3.1-7.9	1	3.3	-	92	202
LC2A015S	Motor	1.5	448	17.6	17	55.8	1.3	46	80-200*	3.1-7.9	1	3.3	3/4	95	209
LC2A030D	Plain	3	592	23.3	-	-	-	-	80-200*	3.1-7.9	2	6.6	-	98	216
LC2A030D	Geared	3	592	23.3	-	-	-	-	80-200*	3.1-7.9	2	6.6	-	100	220
LC2A030D	Motor	3	592	23.3	17	55.8	1.3	46	80-200*	3.1-7.9	2	6.6	3/4	103	227
LC2A040S	Plain	4	590	23.2	-	-	-	-	80-200*	3.1-7.9	2	6.6	-	140	308
LC2A040S	Geared	4	590	23.2	-	-	-	-	80-200*	3.1-7.9	2	6.6	-	142	312
LC2A040S	Motor	4	590	23.2	15	49.2	1.3	46	80-200*	3.1-7.9	2	6.6	3/4	145	319
LC2A060S	Plain	6	730	28.7	-	-	-	-	100-310	3.9-12.2	3	9.8	-	250	550
LC2A060S	Geared	6	730	28.7	-	-	-	-	100-310	3.9-12.2	3	9.8	-	257	565
LC2A060S	Motor	6	730	28.7	15	49.2	1.3	46	100-310	3.9-12.2	3	9.8	3/4	267	587
LC2A060Q	Plain	6	702	27.6	-	-	-	-	100-310	3.9-12.2	3	9.8	-	200	440
LC2A060Q	Geared	6	702	27.6	-	-	-	-	100-310	3.9-12.2	3	9.8	-	207	455
LC2A060Q	Motor	6	702	27.6	15	49.2	1.3	46	100-310	3.9-12.2	3	9.8	3/4	217	477
LC2A080D	Plain	8	815	32.1	-	-	-	-	100-310	3.9-12.2	3	9.8	-	243	535
LC2A080D	Geared	8	815	32.1	-	-	-	-	100-310	3.9-12.2	3	9.8	-	250	550
LC2A080D	Motor	8	815	32.1	12	39.4	1.3	46	100-310	3.9-12.2	3	9.8	3/4	260	572
LC2A120D	Plain	12	995	39.2	-	-	-	-	130-310	5.1-12.2	3	9.8	-	335	737
LC2A120D	Geared	12	995	39.2	-	-	-	-	130-310	5.1-12.2	3	9.8	-	343	755
LC2A120D	Motor	12	995	39.2	12	39.4	1.9	67	130-310	5.1-12.2	3	9.8	3/4	352	774
LC2A125S	Motor	12.5	1,000	39.4	12	39.4	1.9	67	130-310	5.1-12.2	3	9.8	1-1/4	570	1,256
LC2A180T	Plain	18	1,195	47.0	-	-	-	-	140-310	5.5-12.2	5	16.4	-	652	1,434
LC2A180T	Geared	18	1,195	47.0	-	-	-	-	140-310	5.5-12.2	5	16.4	-	660	1,452
LC2A180T	Motor	18	1,195	47.0	15	49.2	1.9	67	140-310	5.5-12.2	5	16.4	3/4	669	1,472
LC2A250Q	Plain	25	1,240	48.8	-	-	-	-	140-310	5.5-12.2	5	16.4	-	700	1,540
LC2A250Q	Geared	25	1,240	48.8	-	-	-	-	140-310	5.5-12.2	5	16.4	-	708	1,558
LC2A250Q	Motor	25	1,240	48.8	12	39.4	1.9	67	140-310	5.5-12.2	5	16.4	3/4	717	1,577
LC2A250D	Motor	25	990	39.0	12	39.4	1.9	67	140-310	5.5-12.2	5	16.4	1-1/4	845	1,859
LC2A375T	Motor	37.5	1,134	44.6	15	49.2	3.8	134	160-310	6.3-12.2	25	82.0	1-1/4	1,650	3,630
LC2A500Q	Motor	50	1,182	46.5	12	39.4	3.8	134	160-310	6.3-12.2	25	82.0	1-1/4	1,950	4,290
LCA750T	Motor	75	1,845	72.6	10	32.8	7.6	268	160-310	6.3-12.2	130	426.4	1-1/4	4,500	9,900
LCA1000Q	Motor	100	1,901	74.8	10	32.8	7.6	268	160-310	6.3-12.2	130	426.4	1-1/4	4,700	10,340

(1) For Low Headroom version, see page 11

(2) Working pressure from 5 to 7 bar (70 to 100 psi)

(3) In Rack & Pinion configuration, the trolley speed is divided by two

(*) 200-310 with Option W



Dimension Drawings - Air: 1.5 to 25 ton (4 falls)

Hook Mount

See page 27 for
chainbucket
dimension
information

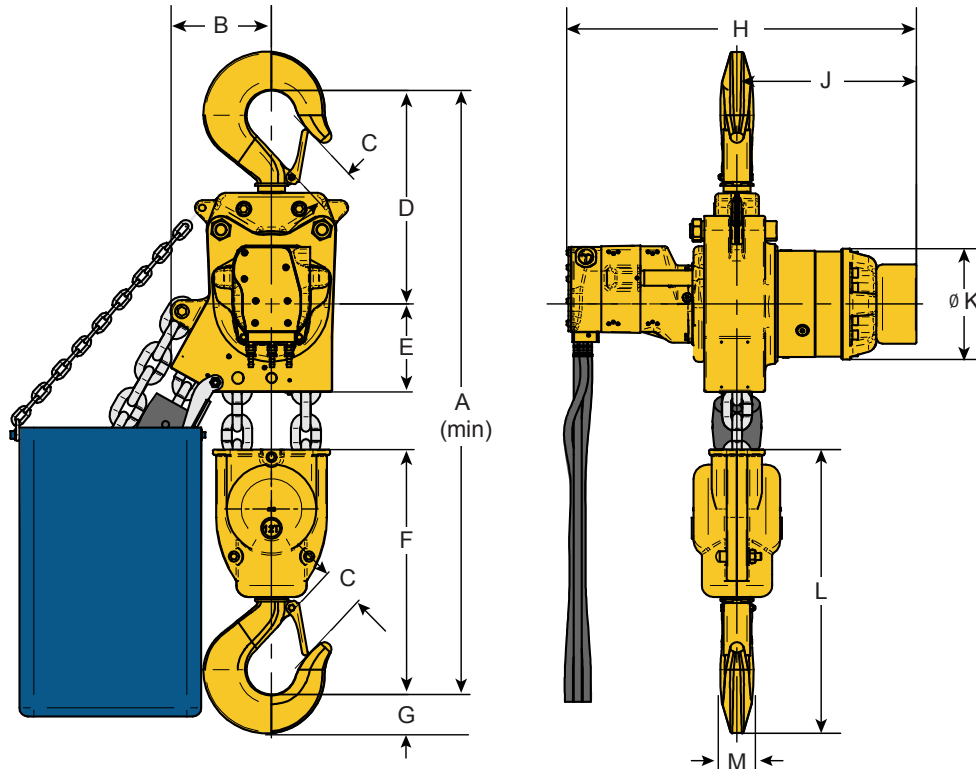

Hook Mount	A		B		C		D		E		F		G		H	
	mm	in	mm	in	mm	in	mm	in	mm	in	mm	in	mm	in	mm	in
LC2A015S	409	16.1	112	4.4	27	1.1	173	6.8	90	3.5	146	5.7	30	1.2	425	16.7
LC2A030D	549	21.6	112	4.4	35	1.4	202	8.0	90	3.5	257	10.1	37	1.5	425	16.7
LC2A040S	580	22.8	183	7.2	35	1.4	264	10.4	127	5.0	190	7.5	37	1.5	606	23.9
LC2A060S	717	28.2	233	9.2	43	1.7	350	13.8	139	5.5	228	9.0	50	2.0	630	24.8
LC2A060Q	653	25.7	112	4.4	43	1.7	266	10.5	90	3.5	296	11.7	50	2.0	394	15.5
LC2A080D	807	31.8	140	5.5	53	2.1	307	12.1	127	5.0	373	14.7	60	2.4	606	23.9
LC2A120D	945	37.2	175	6.9	58	2.3	370	14.6	152	6.0	424	16.7	67	2.6	630	24.8
LC2A125S	865	34.1	276	10.9	58	2.3	368	14.5	200.5	7.9	296	11.7	67	2.6	816	32.1
LC2A180T	1,063	41.9	175	6.9	78	3.1	427	16.8	152	6.0	484	19.1	80	3.1	750	29.5
LC2A250Q	1,156	45.5	175	6.9	87	3.4	474	18.7	152	6.0	530	20.9	96	3.8	750	29.5

Hook Mount	J		K		L		M	
	mm	in	mm	in	mm	in	mm	in
LC2A015S	127	5.0	128	5.0	176	6.9	22	0.9
LC2A030D	127	5.0	128	5.0	294	11.6	32	1.3
LC2A040S	297	11.7	192	7.6	227	8.9	32	1.3
LC2A060S	310	12.2	192	7.6	278	10.9	39	1.5
LC2A060Q	158	6.2	128	5.0	346	13.6	39	1.5
LC2A080D	297	11.7	192	7.6	433	17.0	55	2.2
LC2A120D	310	12.2	192	7.6	491	19.3	57	2.2
LC2A125S	265	10.4	300	11.8	363	14.3	57	2.2
LC2A180T	386	15.2	192	7.6	564	22.2	67	2.6
LC2A250Q	367	14.4	192	7.6	626	24.6	85	3.3

Dimensions are subject to change, contact Customer Services for certified prints.

Dimension Drawings - Air: 25 (double falls) to 100 ton Hook Mount

See page 27 for
chainbucket
dimension
information

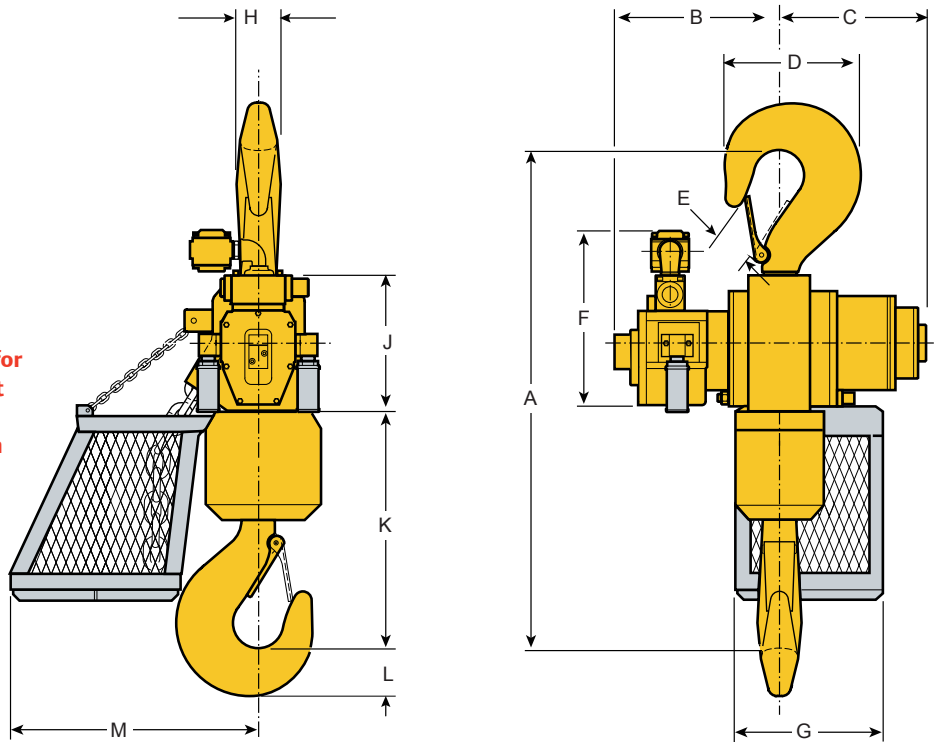

Hook Mount	A		B		C		D		E		F		G		H		J	
	mm	in	mm	in	mm	in	mm	in	mm	in	mm	in	mm	in	mm	in	mm	in
LC2A250D	1,235	48.6	551	21.7	265	10.4	340	13.4	87	3.4	441	17.4	475	18.7	80	3.1	390.5	15.4
LC2A375T	1,484	58.4	605	23.8	373	14.7	390	15.4	103	4.1	441	17.4	475	18.7	125	4.9	406.5	16.0
LC2A500Q	1,590	62.6	632	24.9	346	13.6	440	17.3	118	4.6	441	17.4	475	18.7	140	5.5	415.5	16.4
LCA750T	2,338	92.0	632	24.9	718	28.3	574	22.6	152	6.0	441	17.4	912	35.9	180	7.1	774	30.5
LCA1000Q	2,455	96.7	668	26.3	682	26.9	610	24.0	180	7.1	441	17.4	912	35.9	200	7.9	774	30.5

Hook Mount	K		L		M	
	mm	in	mm	in	mm	in
LC2A250D	572	22.5	94	3.7	836	32.9
LC2A375T	714	28.1	132	5.2	836	32.9
LC2A500Q	763	30.0	150	5.9	836	32.9
LCA750T	1,055	41.5	190	7.5	1,165	45.9
LCA1000Q	1,111	43.7	250	9.8	1,365	53.7

Dimensions are subject to change, contact Customer Services for certified prints.

Dimension Drawings - Air: 1.5 to 25 ton (4 falls)

Trolley Mount - Standard Headroom

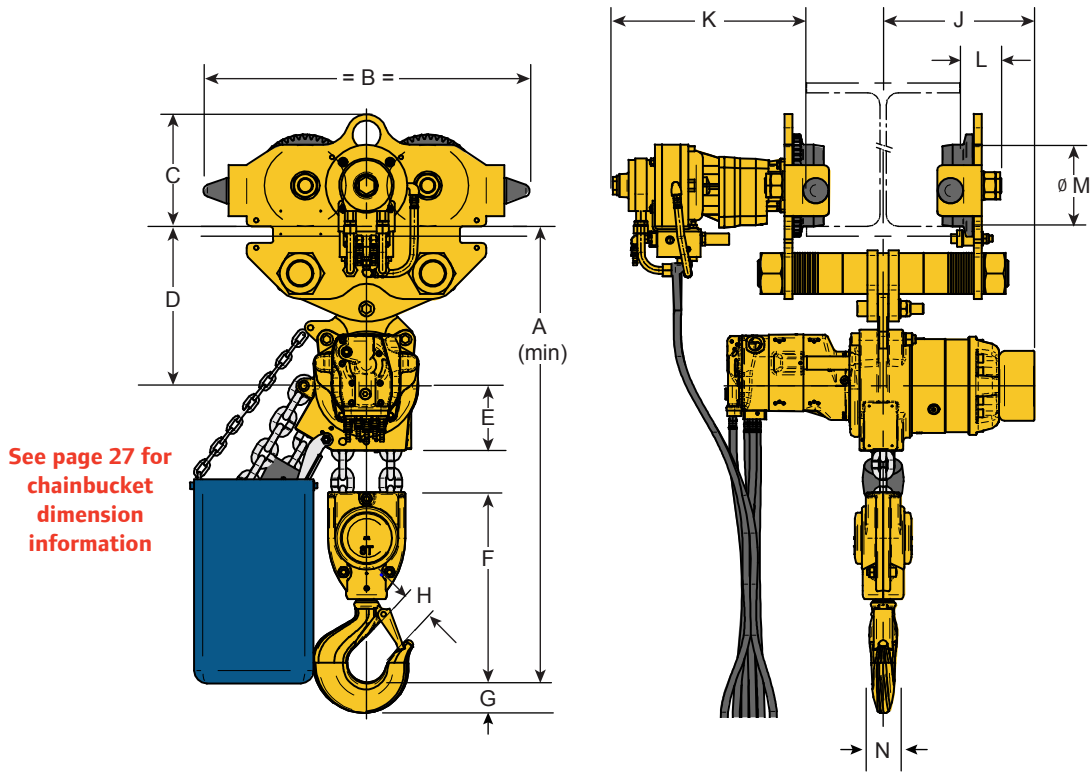

Trolley Mount	A		B		C		D		E		F		G		H	
	mm	in	mm	in	mm	in	mm	in	mm	in	mm	in	mm	in	mm	in
LC2A015S	448	17.6	329	13.0	100	3.9	212	8.3	90	3.5	146	5.7	30	1.2	27	1.1
LC2A030D	592	23.3	436	17.2	147	5.8	244	9.6	90	3.5	257	10.1	37	1.5	35	1.4
LC2A040S	590	23.2	436	17.2	147	5.8	273	10.7	127	5.0	190	7.5	37	1.5	35	1.4
LC2A060S	730	28.7	640	25.2	220	8.7	350	13.8	152	6.0	228	9.0	50	2.0	43	1.7
LC2A060Q	702	27.6	640	25.2	220	8.7	315	12.4	90	3.5	296	11.7	50	2.0	43	1.7
LC2A080D	815	32.1	640	25.2	220	8.7	313	12.3	127	5.0	373	14.7	60	2.4	53	2.1
LC2A120D	995	39.2	622	24.5	220	8.7	420	16.5	152	6.0	424	16.7	67	2.6	58	2.3
LC2A125S	1,000	39.4	622	24.5	220	8.7	498	19.6	201	7.9	296	11.7	67	2.6	58	2.3
LC2A180T	1,195	47.0	790	31.1	270	10.6	558	22.0	152	6.0	484	19.1	80	3.1	78	3.1
LC2A250Q	1,240	48.8	790	31.1	270	10.6	558	22.0	152	6.0	530	20.9	96	3.8	87	3.4

Trolley Mount	J		K		L		M		N	
	mm	in	mm	in	mm	in	mm	in	mm	in
LC2A015S	180	7.1	190	7.5	60	2.4	120	4.7	22	0.9
LC2A030D	180	7.1	190	7.5	60	2.4	120	4.7	32	1.3
LC2A040S	300	11.8	190	7.5	60	2.4	120	4.7	32	1.3
LC2A060S	310	12.2	380	15.0	82	3.2	160	6.3	39	1.5
LC2A060Q	250	9.8	380	15.0	82	3.2	160	6.3	39	1.5
LC2A080D	300	11.8	380	15.0	82	3.2	160	6.3	55	2.2
LC2A120D	310	12.2	410	16.1	91	3.6	160	6.3	57	2.2
LC2A125S	265	10.4	313	12.3	87	3.4	160	6.3	57	2.2
LC2A180T	390	15.4	360	14.2	125	4.9	225	8.9	67	2.6
LC2A250Q	370	14.6	360	14.2	125	4.9	225	8.9	85	3.3



Dimensions are subject to change, contact Customer Services for certified prints.

Dimension Drawings - Air: 25 (double falls) to 100 ton Trolley Mount - Standard Headroom

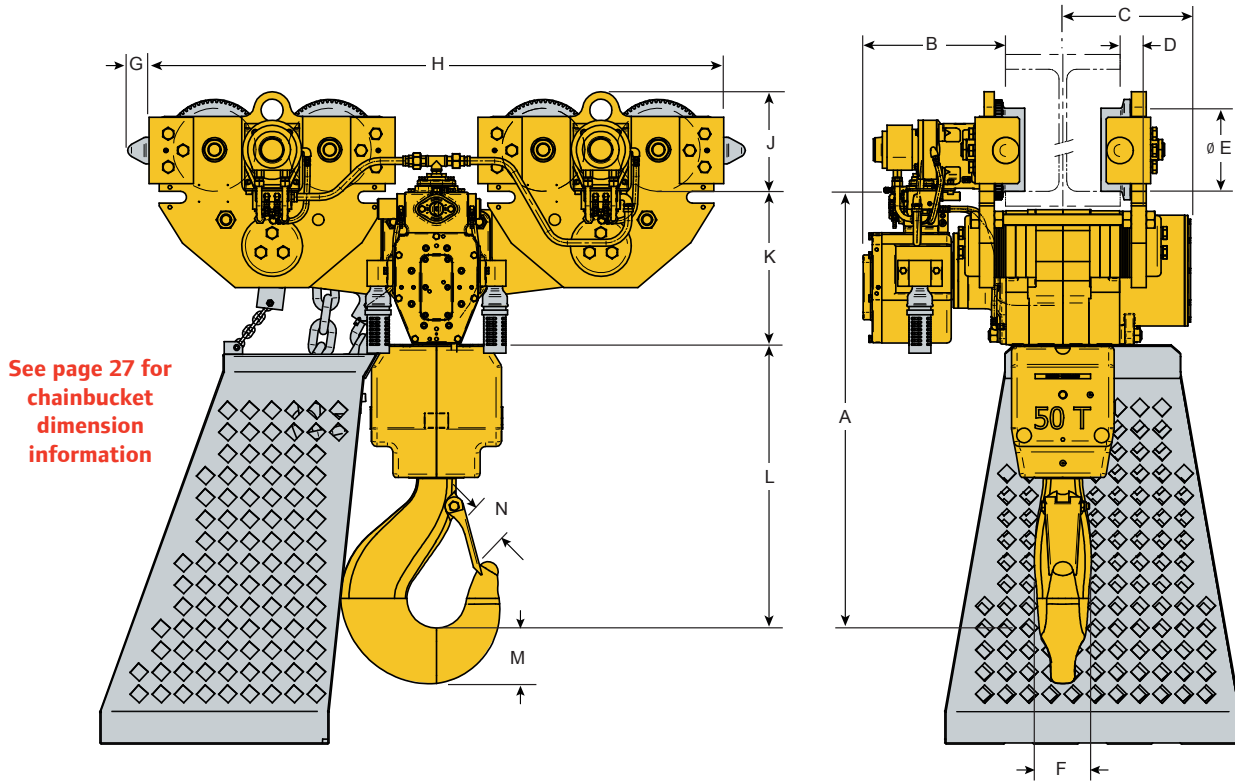

Trolley Mount	A		B		C		D		E		F		G		H		J	
	mm	in	mm	in	mm	in	mm	in	mm	in	mm	in	mm	in	mm	in	mm	in
LC2A250D	990	39.0	484	19.1	265	10.4	87	3.4	160	6.3	84	3.3	58	2.3	1,246	49.1	220	8.7
LC2A375T	1,134	44.6	484	19.1	373	14.7	121	4.8	225	8.9	125	4.9	58	2.3	1,556	61.3	270	10.6
LC2A500Q	1,182	46.5	484	19.1	346	13.6	121	4.8	225	8.9	140	5.5	58	2.3	1,556	61.3	270	10.6
LCA750T	1,845	72.6	484	19.1	714	28.1	341	13.4	225	8.9	180	7.1	58	2.3	3,254	128.1	270	10.6
LCA1000Q	1,901	74.8	484	19.1	678	26.7	341	13.4	225	8.9	200	7.9	58	2.3	3,254	128.1	270	10.6

Trolley Mount	K		L		M		N	
	mm	in	mm	in	mm	in	mm	in
LC2A250D	411	16.2	572	22.5	94	3.7	87	3.4
LC2A375T	416	16.4	714	28.1	132	5.2	103	4.1
LC2A500Q	416	16.4	763	30.0	150	5.9	118	4.6
LCA750T	790	31.1	1,055	41.5	190	7.5	152	6.0
LCA1000Q	790	31.1	1,111	43.7	250	9.8	180	7.1

Ultra Low Headroom chain hoists up to 100 ton capacity are available on request. Contact Technical Sales for further information.

Dimensions are subject to change, contact Customer Services for certified prints.

LIFTCHAIN® - Air: 1.5 to 25 ton

Specifications & Performance - Low Headroom

Low Headroom Motorized Trolley - Performance at 6.3 bar - 90 psi ⁽¹⁾

Model #	Trolley Type	Capacity metric tons	Minimum Headroom		Trolley Speed @ Rated Load		Air Consumption @ Rated Load		Trolley Flange Adjustment		Minimum Curve Radius	Air Inlet BSP
			mm	in	m/min	ft/min	m ³ /min	ft ³ /min	mm	in		
LC2A015S	Motor	1.5	285	11.2	17.0	55.8	1.3	46	82-200	3.2-7.9	NA	3/4
LC2A030D	Motor	3	396	15.6	17.0	55.8	1.3	46	80-200*	3.2-7.9	NA	3/4
LC2A040S	Motor	4	382	15.0	15.0	49.2	1.3	46	80-200*	3.1-7.9	NA	3/4
LC2A060S	Motor	6	443	17.4	12.0	39.4	1.9	67	100-310	3.9-12.2	NA	3/4
LC2A060Q	Motor	6	695	27.4	15.0	49.2	1.3	46	100-310	3.9-12.2	NA	3/4
LC2A080D	Motor	8	521	20.5	12.0	39.4	1.3	46	100-310	3.9-12.2	NA	3/4
LC2A120D	Motor	12	638	25.1	12.0	39.4	1.9	67	130-310	5.2-12.2	NA	3/4
LC2A180T	Motor	18	688	27.1	12.0	39.4	1.9	67	140-310	5.6-12.2	NA	3/4
LC2A250Q	Motor	25	740	29.1	12.0	39.4	1.9	67	140-310	5.5-12.2	NA	3/4

(1) Working pressure from 5 to 7 bar (70 to 100 psi)

(*) 200-310 with Option W



Building rugged and compact hoisting equipment to fit into cramped, confined, and inhospitable spaces is a specialty of Ingersoll Rand.

Our Low and Ultra-Low™ hoisting systems are used in applications where space is at a premium and environments are challenging; offshore oil platforms, underground mining and tunneling, gas processing modules, and shipboard engine rooms.



Dimension Drawings - Air: 1.5 to 25 ton

Trolley Mount - Low Headroom

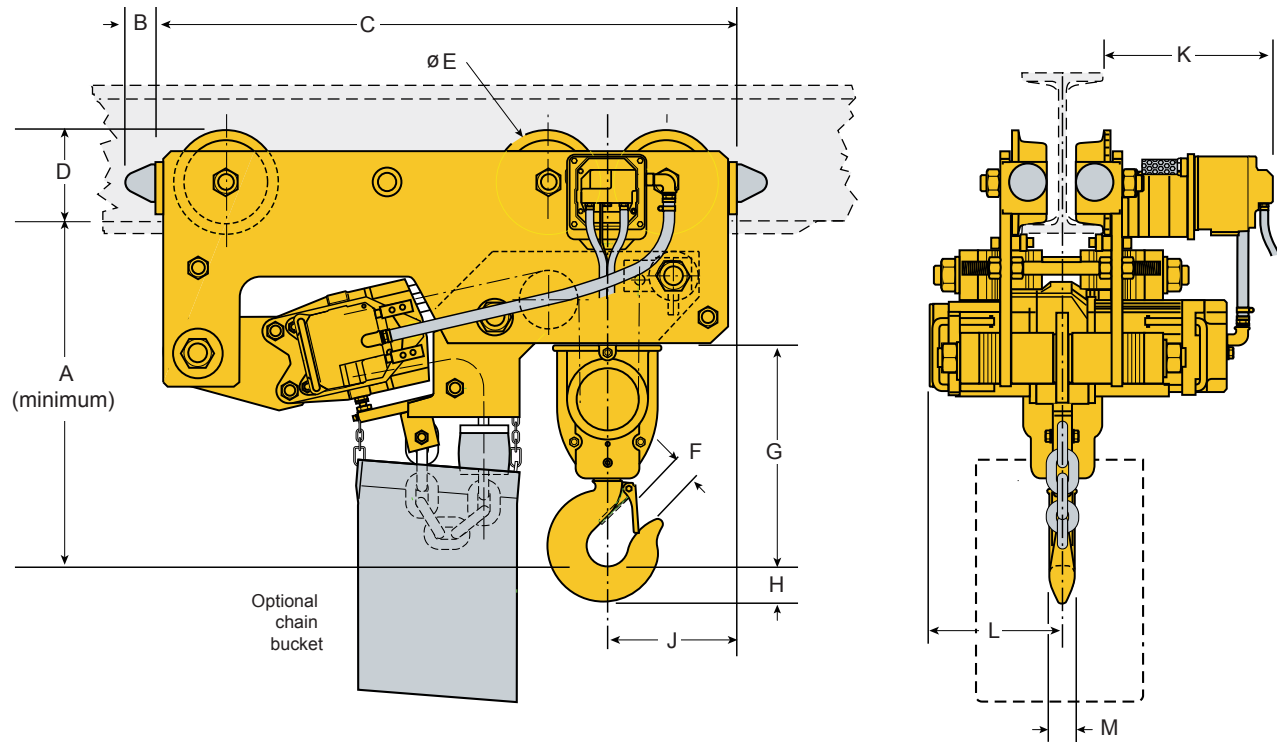

Trolley Mount	A		B		C		D		E		F		G		H		J	
	mm	in	mm	in	mm	in	mm	in	mm	in	mm	in	mm	in	mm	in	mm	in
LC2A015S	285	11.2	19	0.7	631	24.8	135	5.3	120	4.7	212	8.3	560	22.0	27	1.1	147	5.8
LC2A030D	396	15.6	19	0.7	631	24.8	135	5.3	120	4.7	212	8.3	560	22.0	32	1.3	258	10.2
LC2A040S	382	15.0	58	2.3	966	38.0	180	7.1	160	6.3	361	14.2	819	32.2	32	1.3	185	7.3
LC2A060S	443	17.4	58	2.3	1,111	43.7	180	7.1	160	6.3	435	17.1	976	38.4	43	1.7	228.5	9.0
LC2A080D	521	20.5	58	2.3	966	38.0	180	7.1	160	6.3	361	14.2	819	32.2	40	1.6	333	13.1
LC2A120D	638	25.1	58	2.3	1,111	43.7	180	7.1	160	6.3	435	17.1	976	38.4	58	2.3	423.5	16.7
LC2A180T	688	27.1	58	2.3	1,245	49.0	249	9.8	225	8.9	441	17.4	967	38.1	78	3.1	467	18.4
LC2A250Q	740	29.1	58	2.3	1,301	51.2	249	9.8	225	8.9	441	17.4	967	38.1	87	3.4	519	20.4

Trolley Mount	K		L		M	
	mm	in	mm	in	mm	in
LC2A015S	190	7.5	127	5.0	22	0.9
LC2A030D	190	7.5	127	5.0	32	1.3
LC2A040S	190	7.5	300	11.8	32	1.3
LC2A060S	326	12.8	252.5	9.9	39	1.5
LC2A080D	380	15.0	300	11.8	55	2.2
LC2A120D	326	12.8	252.5	9.9	57	2.2
LC2A180T	332	13.1	252.5	9.9	67	2.6
LC2A250Q	332	13.1	252.5	9.9	85	3.3

Ultra Low Headroom chain hoists up to 100 ton capacity are available on request. Contact Technical Sales for further information.

Dimensions are subject to change, contact Customer Services for certified prints.

LIFTCHAIN® Hydraulic Chain Hoists

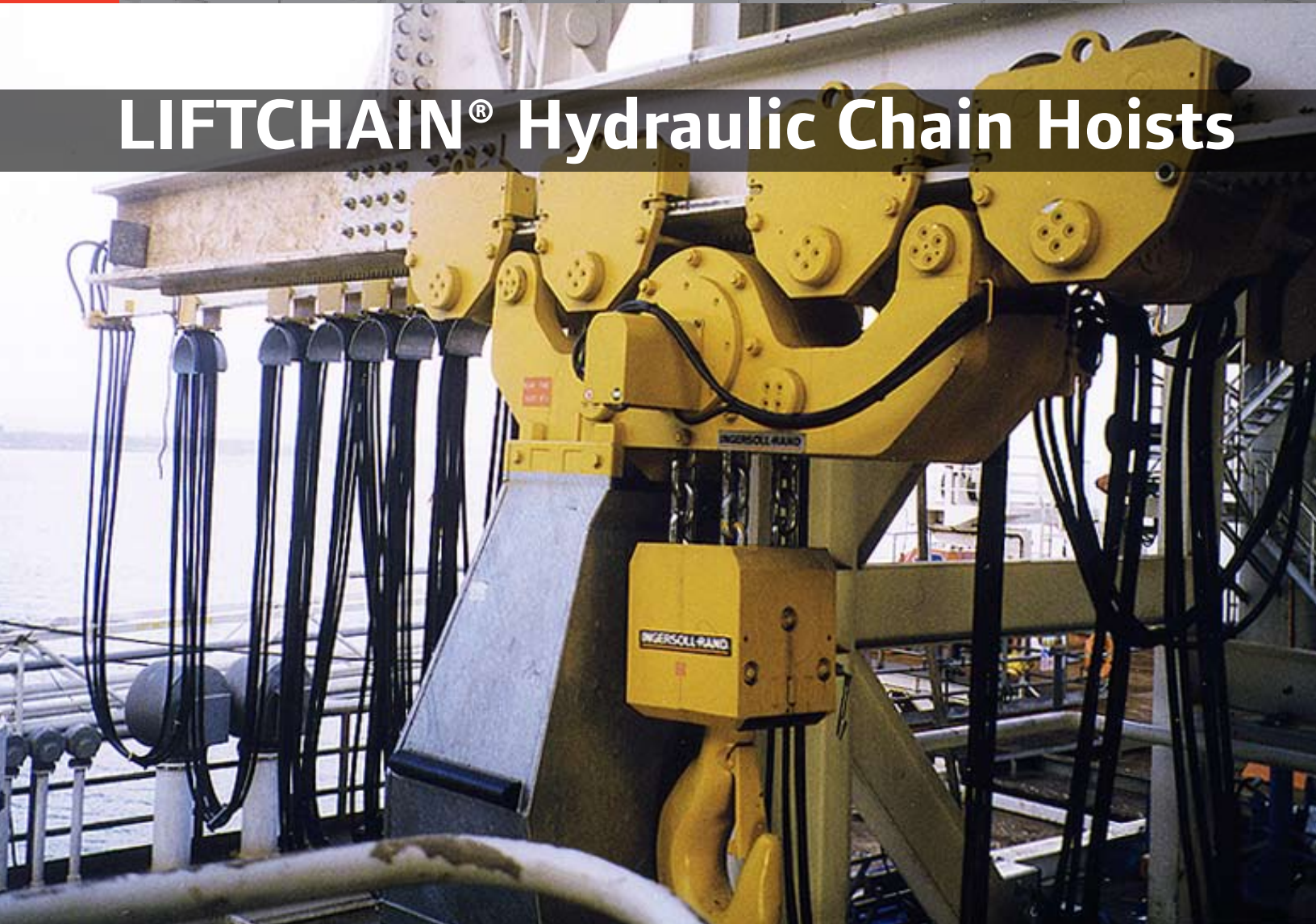

- The LIFTCHAIN® Hydraulic Chain Hoist series is an innovative alternative to our air driven chain hoists. Capacities from 6 to 100 metric ton.
- Very low noise level
- Extremely sensitive variable speed control of lifting and travelling motions
- Easy installation and operation
- Lower energy cost

LIFTCHAIN® Hydraulic Hoist Series: 6 to 100 ton

Features and Options

LIFTCHAIN® Hydraulic Hoists Series Common Features

- **Rugged, Compact Design and Light Weight**
 - All steel construction for better durability. Particularly adapted for difficult environments.
 - Insensitive to dust and humidity
 - 100% duty cycle
- **Suitable for Hazardous Explosion Proof Environments**
 - Hydraulic motors (unlike electric motors) are inherently explosion proof
 - ATEX classification (as per directive EC 94/9/EEC)
 - Standard models are suitable for zone 2
 - Marking Ex II 3 GD c IIB 135°C X
 - Optional spark protection package for zone 1
 - Marking EX II 2 GD c IIB 135°C
- **Automatic Multi Disc Brake**
 - Fully enclosed for better protection and corrosion resistance
 - No adjustment required. Maintenance free.
- **Overload Protection Device**
 - Hoist is shut off and brake sets when overload of 125 – 130% is detected
 - Superior durability compared to mechanical slip clutch which wears and generates damaging heat
 - Prevents high forces being applied to the hoist and the customer support structure
- **Upper and Lower Limit Switches**
 - Integrated in the hoist body for better protection
 - No adjustment required
- **Reduced Maintenance**
 - Innovative modular concept allowing easy inspections and maintenance for major components
- **Corrosion Resistant Load Chain**
 - Grade 80 calibrated load chain
 - Corrosion resistant treated for better protection and longer life
 - 5:1 design factor for safety and durability
- **Smart Design Bottom Blocks**
 - Bottom hook mounted on ball bearing for easier, smoother turning under load
 - Water drain hole to drain water from block
 - External lubrication point for better durability and ease of maintenance
- **Options and Accessories**
 - Plain, geared and motorized trolleys
 - Chain containers (canvas or metal)
 - Marine paint systems
 - Spark resistant package for ATEX Zone 1
 - Rack & pinion trolley drive configuration
 - 3.1b & 2.2 Material traceability certificates
 - Festooning systems

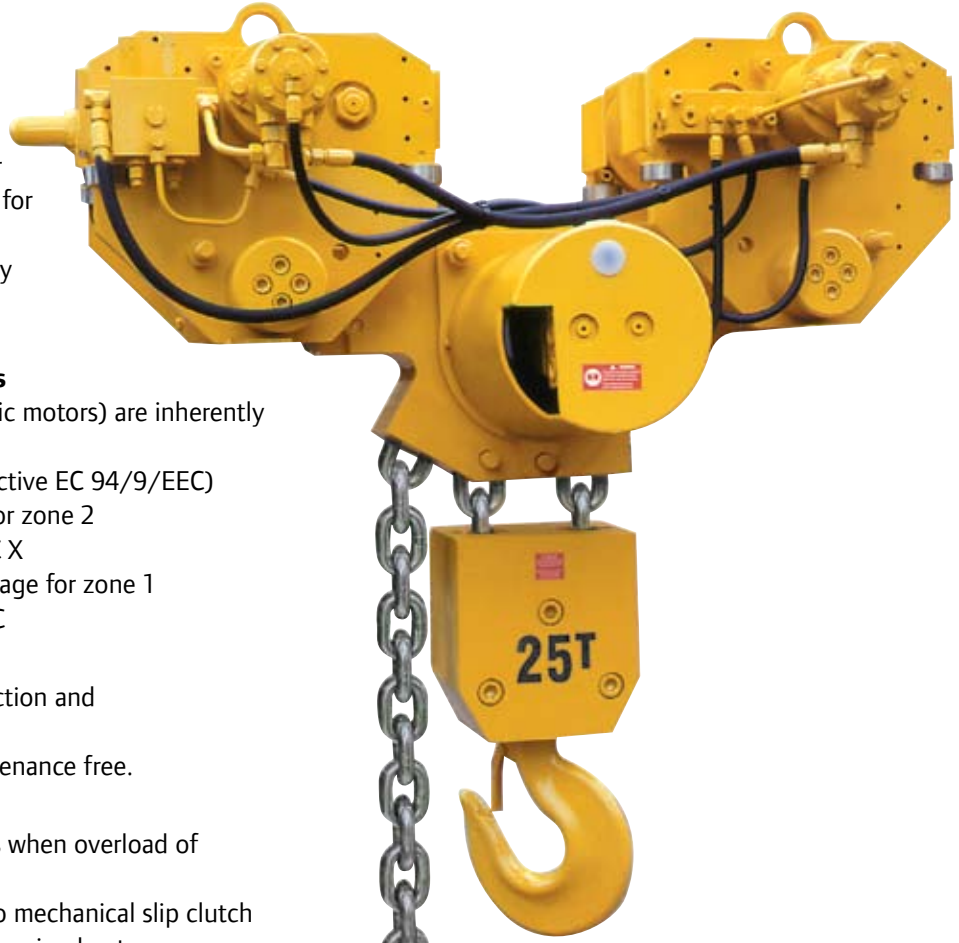

LIFTCHAIN® - Hydraulic: 6 to 100 ton

Hook Mount & Trolley Mount Specifications & Performance



Selection Guide - Hydraulic Chain Hoists

Model #	Capacity		Lifting Speed @ Rated Load		Hook Mount Headroom		Trolley Mount Headroom	
	metric tons	# Falls	m/min	ft/min	mm	in	mm	in
LCH060S	6	1	5.6	18.4	735	28.9	792	30.0
LCH120D	12	2	2.8	9.2	991	39.0	999	39.3
LC2H125S	12.5	1	4.6	15.1	865	34.1	1,000	39.4
LCH180T	18	3	1.9	6.2	1,083	42.6	1,241	48.9
LCH250Q	25	4	1.4	4.6	1,180	46.5	1,290	50.8
LC2H250D	25	2	2.3	7.5	1,235	48.6	990	39.0
LC2H375T	37.5	3	1.5	4.9	1,484	58.4	1,134	44.6
LC2H500Q	50	4	1.1	3.6	1,590	62.6	1,182	46.5
LCH750T	75	3	0.5	1.6	2,338	92.0	1,845	72.6
LCH1000Q	100	4	0.4	1.3	2,455	96.7	1,901	74.8

Controls

Control systems, hoses and fittings are delivered as separate accessories. The LCH Series can be provided with control systems such as:

- Hydraulic control console for hoist only, hoist / trolley combination, or for complete lifting system (e.g. systems with 2 or 4 hoist / trolley combination).
- Electro-hydraulic control console, also available for all types of configurations
- Hydraulic pendant control from 6 ton models with motorized trolley.

All these control systems can be delivered with emergency stop device on request.



LIFTCHAIN® - Hydraulic: 6 to 100 ton

Specifications & Performance

Hook Mount

Model #	Capacity		Minimum Headroom		Lifting Speed				Lowering Speed		Nominal Flow		Working Pressure		Chain Size		Chain Weight (per mtr of lift)		Net Weight w/3m of Lift	
	metric tons	#Falls	mm	in	Rated Load	No Load	Rated Load	No Load	Rated Load	No Load	L/min	g/min	bar	psi	mm	kg	lbs	kg	lbs	
LCH060S	6	1	735	28.9	5.6	18.4	5.6	18.4	5.6	18.4	48	12.68	140	2,030	16x45	5.8	12.7	93	204.6	
LCH120D ⁽¹⁾	12	2	991	39.0	2.8	9.2	2.8	9.2	2.8	9.2	48	12.68	140	2,030	16x45	11.5	25.3	175	385.0	
LC2H125S	12.5	1	865	34.1	4.6	15.1	4.6	15.1	4.6	15.1	50	13.21	180	2,610	22x66	10.7	23.5	500	1,100.0	
LCH180T ⁽²⁾	18	3	1,083	42.6	1.9	6.2	1.9	6.2	1.9	6.2	48	12.68	140	2,030	16x45	17.2	37.8	200	440.0	
LCH250Q ⁽³⁾	25	4	1,180	46.5	1.4	4.6	1.4	4.6	1.4	4.6	48	12.68	140	2,030	16x45	23.0	50.6	430	946.0	
LC2H250D	25	2	1,235	48.6	2.3	7.5	2.3	7.5	2.3	7.5	50	13.21	180	2,610	22x66	21.4	47.1	670	1,474.0	
LC2H375T	37.5	3	1,484	58.4	1.5	4.9	1.5	4.9	1.5	4.9	50	13.21	180	2,610	22x66	32.1	70.6	875	1,925.0	
LC2H500Q	50	4	1,590	62.6	1.1	3.6	1.1	3.6	1.1	3.6	50	13.21	180	2,610	22x66	42.8	94.2	950	2,090.0	
LCH750T	75	3	2,338	92.0	0.5	1.6	0.5	1.6	0.5	1.6	40	10.57	150	2,175	32x90	73.5	161.7	2,800	6,160.0	
LCH1000Q	100	4	2,455	96.7	0.4	1.3	0.4	1.3	0.4	1.3	40	10.57	150	2,175	32x90	98.0	215.6	3,245	7,139.0	

(1) Maximum allowed height of lift is 20 m

(2) Maximum allowed height of lift is 13 m

(3) Maximum allowed height of lift is 10 m



Units Featured:

- 4 hydraulic trolley hoist units, 37.5 metric ton each, used on an offshore rig.

LIFTCHAIN® - Hydraulic: 6 to 100 ton

Specifications & Performance - Standard Headroom ⁽¹⁾

Trolley Mount

Model #	Trolley Type	Capacity metric tons	Minimum Headroom		Trolley Speed @ Rated Load ⁽²⁾		Trolley Nominal Flow		Trolley Flange Adjustment		Minimum Curve Radius		Net Weight w/3m of Lift	
			mm	in	m/min	ft/min	L/min	g/min	mm	in	m	ft	kg	lbs
LCH060S	Plain	6	762	30.0	-	-	-	-	98-310	3.9-12.2	3	9.8	270	594
LCH060S	Geared	6	762	30.0	-	-	-	-	98-310	3.9-12.2	3	9.8	270	594
LCH060S	Motorized	6	762	30.0	15	49.2	10	2.64	98-310	3.9-12.2	3	9.8	292	642
LCH120D	Plain	12	999	39.3	-	-	-	-	131-310	5.2-12.2	3	9.8	335	737
LCH120D	Geared	12	999	39.3	-	-	-	-	131-310	5.2-12.2	3	9.8	335	737
LCH120D	Motorized	12	999	39.3	15	49.2	10	2.64	131-310	5.2-12.2	3	9.8	351	772
LC2H125S	Motorized	12.5	1,000	39.4	15	49.2	10	2.64	131-310	5.2-12.2	3	9.8	420	924
LCH180T	Plain	18	1,241	48.9	-	-	-	-	143-310	5.6-12.2	3	9.8	420	924
LCH180T	Motorized	18	1,241	48.9	15	49.2	10	2.64	143-310	5.6-12.2	3	9.8	435	957
LCH250Q	Plain	25	1,290	50.8	-	-	-	-	143-310	5.6-12.2	3	9.8	440	968
LCH250Q	Motorized	25	1,290	50.8	15	49.2	10	2.64	143-310	5.6-12.2	3	9.8	450	990
LC2H250D	Motorized	25	990	39.0	15	49.2	10	2.64	160-310	6.3-12.2	25	82.0	1,000	2,200
LC2H375T	Motorized	37.5	1,134	44.6	15	49.2	10	2.64	160-310	6.3-12.2	25	82.0	1,600	3,520
LC2H500Q	Motorized	50	1,182	46.5	15	49.2	10	2.64	160-310	6.3-12.2	25	82.0	1,600	3,520
LCH750T	Motorized	75	1,845	72.6	15	49.2	20	5.28	160-310	6.3-12.2	130	426.4	4,720	10,384
LCH1000Q	Motorized	100	1,901	74.8	15	49.2	20	5.28	160-310	6.3-12.2	130	426.4	5,900	12,980

(1) For Low Headroom version, please contact Customer Services

(2) In Rack & Pinion configuration, the trolley speed is reduced to 9 m/min (29.5 ft/min) and the oil flow is increased to 30 L/min (7.92 g/min)

Ingersoll Rand has a global network of authorized service centers which can provide inspection, testing, repair, and a variety of other maintenance services.

Tip:

American National Standards Institute / American Society of Mechanical Engineers (ANSI/ASME) and Ingersoll Rand recommends that a hoist or winch (or any component of said) that has been repaired should be tested prior to being placed into service.



Dimension Drawings - Hydraulic: 6 to 25 ton (4 falls) Hook Mount

See page 28 for chainbucket dimension information

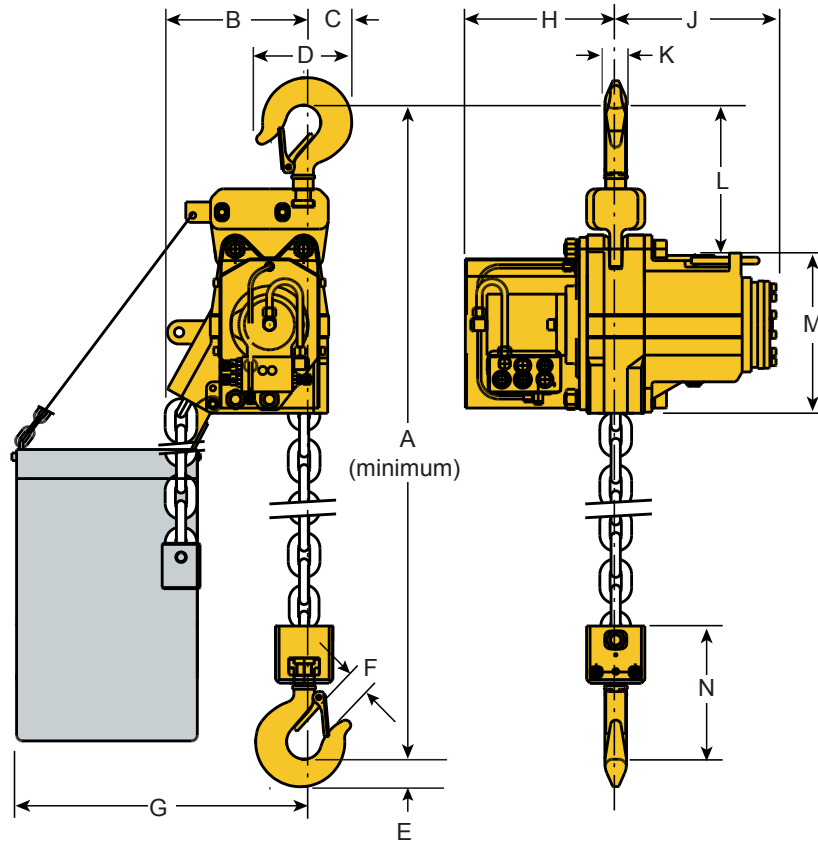

Hook Mount	A		B		C		D		E		F		G		H		J	
	mm	in	mm	in	mm	in	mm	in	mm	in	mm	in	mm	in	mm	in	mm	in
LCH060S	735	28.9	175	6.9	101	4.0	203	8.0	46	1.8	43	1.7	435	17.1	275	10.8	258	10.2
LCH120D	991	39.0	175	6.9	101	4.0	203	8.0	67	2.6	58	2.3	435	17.1	275	10.8	258	10.2
LCH180T	1,083	42.6	175	6.9	101	4.0	203	8.0	78	3.1	78	3.1	435	17.1	352	13.9	298	11.7
LCH250Q	1,180	46.5	175	6.9	101	4.0	203	8.0	99	3.9	87	3.4	435	17.1	333	13.1	316	12.4

Hook Mount	K		L		M		N	
	mm	in	mm	in	mm	in	mm	in
LCH060S	35	1.4	241	9.5	218	8.6	223	8.8
LCH120D	50	2.0	280	11.0	282	11.1	423	16.7
LCH180T	62	2.4	320	12.6	282	11.1	478	18.8
LCH250Q	87	3.4	368	14.5	282	11.1	527	20.7

Dimensions are subject to change, contact Customer Services for certified prints.

Dimension Drawings - Hydraulic: 12.5 to 100 ton Hook Mount

See page 28 for
chainbucket
dimension
information

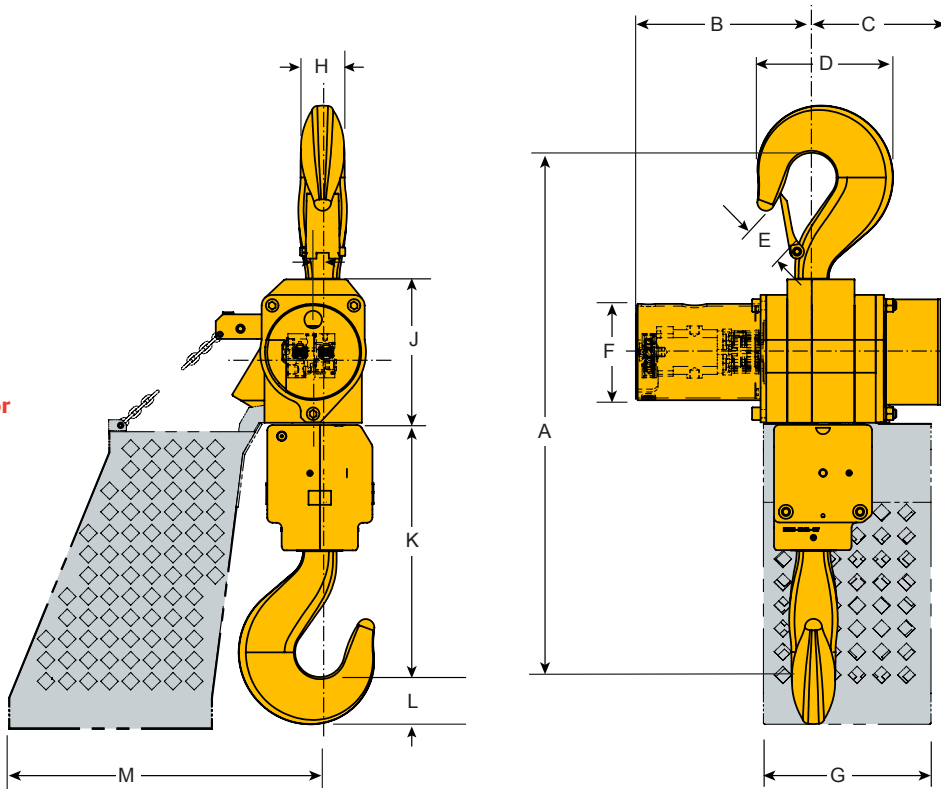

Hook Mount	A		B		C		D		E		F		G		H		J	
	mm	in	mm	in	mm	in	mm	in	mm	in	mm	in	mm	in	mm	in	mm	in
LC2H125S	865	34.1	446	17.6	265	10.4	222	8.7	58	2.3	273	10.7	475	18.7	57	2.2	391	15.4
LC2H250D	1,235	48.6	446	17.6	265	10.4	340	13.4	87	3.4	273	10.7	475	18.7	80	3.1	391	15.4
LC2H375T	1,484	58.4	500	19.7	373	14.7	390	15.4	103	4.1	273	10.7	475	18.7	125	4.9	407	16.0
LC2H500Q	1,590	62.6	527	20.7	346	13.6	440	17.3	118	4.6	273	10.7	475	18.7	140	5.5	416	16.4
LCH750T	2,338	92.0	560	22.0	688	27.1	574	22.6	156	6.1	273	10.7	912	35.9	180	7.1	774	30.5
LCH1000Q	2,455	96.7	597	23.5	652	25.7	610	24.0	180	7.1	273	10.7	1,102	43.4	200	7.9	774	30.5

Hook Mount	K		L		M	
	mm	in	mm	in	mm	in
LC2H125S	296	11.7	67	2.6	836	32.9
LC2H250D	573	22.6	94	3.7	836	32.9
LC2H375T	714	28.1	132	5.2	836	32.9
LC2H500Q	763	30.0	150	5.9	836	32.9
LCH750T	1,055	41.5	190	7.5	1,165	45.9
LCH1000Q	1,111	43.7	250	9.8	1,365	53.7

Dimensions are subject to change, contact Customer Services for certified prints.

Dimension Drawings - Hydraulic: 6 to 25 ton (4 falls)

Trolley Mount - Standard Headroom

See page 28 for chainbucket dimension information

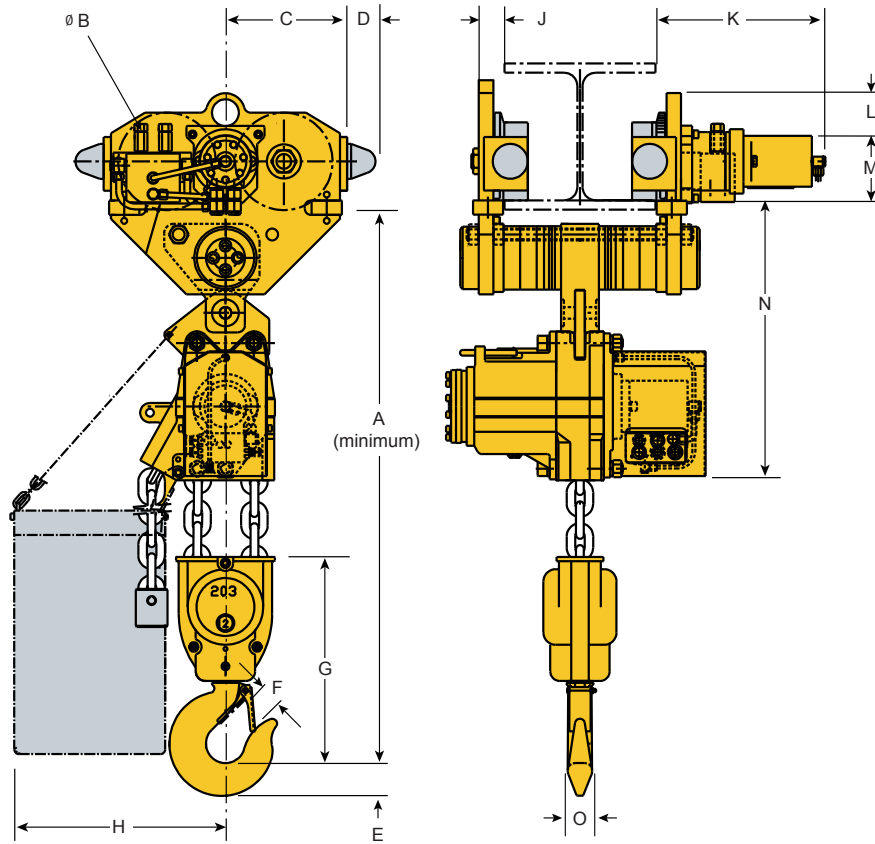

Trolley Mount	A		B		C		D		E		F		G		H		J	
	mm	in	mm	in	mm	in	mm	in	mm	in	mm	in	mm	in	mm	in	mm	in
LCH060S	762	30.0	160	6.3	270	10.6	50	2.0	49	1.9	43	1.7	228.5	9.0	494	19.4	42	1.7
LCH120D	999	39.3	160	6.3	253	10.0	58	2.3	67	2.6	58	2.3	423.5	16.7	435	17.1	52	2.0
LC2H125S	1,000	39.4	160	6.3	253	10.0	58	2.3	67	2.6	58	2.3	296	11.7	916	36.1	86	3.4
LCH180T	1,241	48.9	225	8.9	337	13.3	58	2.3	80	3.1	78	3.1	484	19.1	454	17.9	69	2.7
LCH250Q	1,290	50.8	225	8.9	337	13.3	58	2.3	94	3.7	87	3.4	533	21.0	435	17.1	69	2.7

Trolley Mount	K		L		M		N		O	
	mm	in	mm	in	mm	in	mm	in	mm	in
LCH060S	339	13.3	43	1.7	177	7.0	502	19.8	39	1.5
LCH120D	350	13.8	64	2.5	157	6.2	655	25.8	57	2.2
LC2H125S	347	13.7	88	3.5	133	5.2	700	27.6	57	2.2
LCH180T	360	14.2	81	3.2	189	7.4	710	28.0	67	2.6
LCH250Q	360	14.2	81	3.2	189	7.4	710	28.0	85	3.3

Dimensions are subject to change, contact Customer Services for certified prints.

Hydraulic Chain Hoists

Dimension Drawings - Hydraulic: 25 (2 falls) to 100 ton Trolley Mount - Standard Headroom

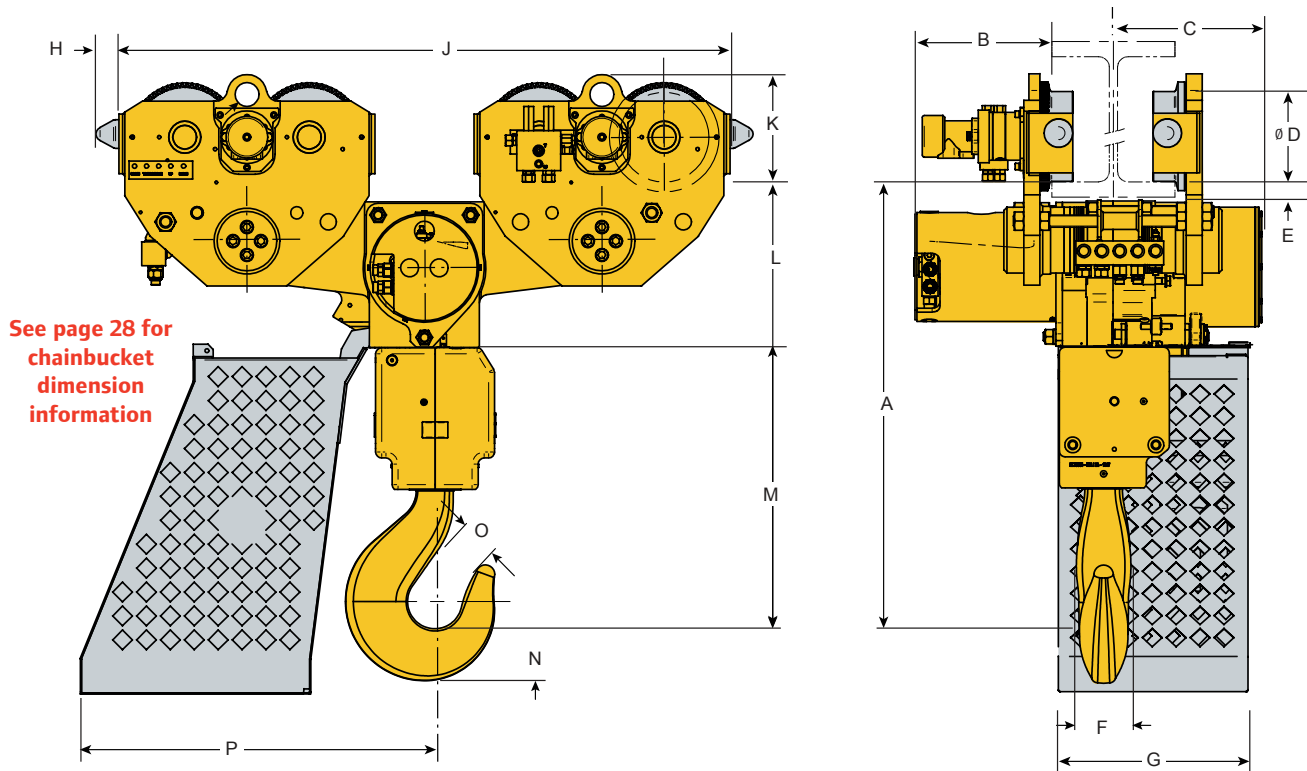

Trolley Mount	A		B		C		D		E		F		G		H		J	
	mm	in	mm	in	mm	in	mm	in	mm	in	mm	in	mm	in	mm	in	mm	in
LC2H250D	990	39.0	343	13.5	265	10.4	160	6.3	40	1.6	84	3.3	475	18.7	58	2.3	1,246	49.1
LC2H375T	1,134	44.6	372	14.6	373	14.7	225	8.9	40	1.6	125	4.9	475	18.7	58	2.3	1,556	61.3
LC2H500Q	1,182	46.5	372	14.6	346	13.6	225	8.9	40	1.6	140	5.5	475	18.7	58	2.3	1,556	61.3
LCH750T	1,845	72.6	376	14.8	684	26.9	225	8.9	70	2.8	180	7.1	1,102	43.4	58	2.3	3,254	128.1
LCH1000Q	1,901	74.8	376	14.8	652	25.7	225	8.9	70	2.8	200	7.9	1,021	40.2	58	2.3	3,254	128.1

Trolley Mount	K		L		M		N		O		P	
	mm	in	mm	in	mm	in	mm	in	mm	in	mm	in
LC2H250D	220	8.7	411	16.2	572	22.5	94	3.7	87	3.4	836	32.9
LC2H375T	270	10.6	416	16.4	714	28.1	132	5.2	103	4.1	836	32.9
LC2H500Q	270	10.6	416	16.4	763	30.0	150	5.9	118	4.6	836	32.9
LCH750T	270	10.6	790	31.1	1,055	41.5	190	7.5	152	6.0	1,402	55.2
LCH1000Q	270	10.6	790	31.1	1,111	43.7	212	8.3	180	7.1	1,366	53.8

Dimensions are subject to change, contact Customer Services for certified prints.

How To Order

Model identification Codes

How to order standard equipment

Specify the complete model number as shown. Specify beam size, type and flange width. Note that 0 (zero) is a number, not a letter in model part numbers.

Example: LC2A250QIP3RE10M15J12-E

LC2	A	250Q	IP	3	RE	10M	15	J12	-E
Series LC = LIFTCHAIN® Series LC2 = LIFTCHAIN® Series, 2nd generation	Power type A = Air H = Hydraulic	Body type IP = Industrial range, pendent control IC = Industrial range, pull cord IF = Industrial range, full flow control (Hydraulic models only)	Control type Only with IC models 1 = Pull cord Only with IP models 2 = 1 motor pendent 3 = 2 motor pendent ⁽³⁾ 0 = No pendent or no control valve	Height of lift 3M = 3 meter standard lift XXM = Specified length in meters	Control length 0 = no control hose XX = Specified length in meters	CE package -E = Compliance with the European Machinery Directives	Load capacity / falls of chain 015S = 1.5 ton / single fall 030D = 3 ton / two falls 040S = 4 ton / single fall 060S = 6 ton / single fall 080D = 8 ton / two falls 120D = 12 ton / two falls 125S = 12.5 ton / single fall 180T = 18 ton / three falls 250D = 25 ton / two falls 250Q = 25 ton / four falls 375T = 37.5 ton / three falls 500Q = 50 ton / four falls 750T = 75 ton / three falls 1000Q = 100 ton / four falls	Suspension A = Fixed lug C = Swivel top hook PU ⁽¹⁾ = Plain rigid universal trolley (flat or tapered beam / 1.5 to 8 ton) PE ⁽¹⁾ = Plain rigid trolley (flat beam / 12 to 25 ton) PN ⁽¹⁾ = Plain rigid trolley (tapered beam / 12 to 25 ton) GU ⁽¹⁾ = Geared rigid universal trolley (flat or tapered beam / 1.5 to 8 ton) GE ⁽¹⁾ = Geared rigid trolley (flat beam / 12 ton only) GN ⁽¹⁾ = Geared rigid trolley (tapered beam / 12 ton only) VU ⁽¹⁾⁽²⁾ = Vane motorized rigid universal trolley (flat or tapered beam / 1.5 to 8 ton) VE ⁽¹⁾⁽²⁾ = Vane motorized rigid trolley (flat beam / 12 to 50 ton) VN ⁽¹⁾⁽²⁾ = Vane motorized rigid trolley (tapered beam / 12 to 50 ton) RU = Gear motorized rigid universal trolley (flat or tapered beam) 6,000 and 8,000 kg RE = Gear motorized rigid trolley (flat beam) 12 to 100 ton RN = Gear motorized rigid trolley (tapered beam) 12 to 100 ton	Options A = Standard chain bucket B = Large chain bucket C = Extra large chain bucket J = Air Line Accessories.* (Air only) Specify J1: Filter, J2: Lubricator, J3: Regulator or any numerical combination K = Cast iron pendent (Air only) L = Low Temperature (-20°C) Certified (includes 3.1b material traceability certificates) P = Marine paint 150µ QZ = Offshore paint 290µ including sandblasting T1 = Spark resistant package (ATEX zone 1**)

(1) Add "L" for low headroom trolley, e.g. LVU or LRU.

(2) Add the letter "R" for rack & pinion configuration (e.g. RER) - on flat beam only.

(3) For hydraulic trolley hoists, pendent configuration is joystick-style.

* For protection during shipment and due to the wide range of installation variables the air line accessories are not installed on the units at the factory. All accessories are shipped loose for client installation.

** Option T1 (ATEX Zone 1) includes the following:

For the hoist: - Cast iron pendent - Bronze coated bottom hook assy

For the trolley: - Solid bronze wheels - Pinion drive in solid bronze or stainless steel - Cast iron pendent
 - Bronze coated hand wheel for geared trolley - Brass hand chain guide for geared trolley



Compliance with the European Machinery Directives:

LCA/LC2A and LCH

The LIFTCHAIN® air and hydraulic models can be CE marked and fitted as standard with all the safety devices for compliance with the European Machinery Directives 89/392/EEC, 91/368/EEC, 93/44/EEC and 93/68/EEC. In this case, they are delivered with the CE mark and an EC declaration of conformity.

LCA/LC2A and LCH delivered without control

These models are considered as part machines intended for incorporation into assemblies, therefore they are not CE marked but are delivered with a declaration of incorporation. However they are fitted as standard with safety options to allow their incorporation into systems which have to be in compliance with the CE Directives (89/392/EEC, 91/368/EEC, 93/44/EEC, 93/68/EEC).

Service & Accessories

Service

Winch and Hoist Service Made Simple

By choosing Ingersoll Rand Winch and Hoist equipment you've made a critical investment in the performance and life of your operations. We recognize this investment and are committed to providing you with a responsive and flexible program for maintaining your equipment and reducing downtime.

Ingersoll Rand can tailor a variety of service options to meet your application's specific requirements. Please contact us to make an appointment to discuss a customized service plan that best suits your needs.

Installation and Start-Up Assistance



Inspector and Operator Training

System Inspections

Service & Accessories

Service

Repairs Done Right



Routine Maintenance



Service and Repair



Equipment Refurbishments

Service & Accessories

Accessories

FRL's

Port ⁽¹⁾ Thread	Port ⁽¹⁾ Size	Part Number	CPN	Item Type	Combination Weight		Inlet Pressure Max		Temp Range		Flow		Filter	Regulator	Lubricator
					lbs	kg	psi	bar	F	C	scfm	m ³ /min			
NPT	3/4"	C38451-810	15317506	3-Piece Combination	18.2	8.2	250	17.2	23-175	-5-79.4	199	5.6	F35451-410	R37451-600	L36351-110
BSP	3/4"	79990066	38529681	3-Piece Combination	18.2	8.2	250	17.2	32-150	0-65.5	220	6.2	F39-C6-SL00-29	R21-C6-000-29	L39-C6-LD00-29
NPT	1-1/4"	- ⁽²⁾	-	-	34.7	15.7	150	10.3	32-150	0-65.5	800	22.6	F35571-410	R37571-100 ⁽³⁾	L36571-110
BSP	1-1/4"	79990070	38529749	3-Piece Combination	32.7	14.8	150	10.3	32-125	0-51.6	800	22.6	F35-CA-A29	R31-CA-000-29	L40-CA-A29

(1) Hoists with a 3/4" BSP inlet port may use either 3/4" NPT or BSP fittings. (2) The 1-1/4" NPT FRL's are not offered in combination. Order separately by part number and use 1-1/4" nipples to make combinations. A 1-1/4" BSP to NPT nipple must be used to connect to the hoist. (3) R37571-100 is not supplied with a gauge. Order Part Number 104502 for a 0-160 psi gauge. (4) See Accessory catalog for additional specifications.

Lubricants

Part Number	CPN	Description	Where Used	Size
Lubri-Link-Green LLG-5	71124754 71261291	Triple protection USDA approved lubricant. Extreme pressure formula and corrosion inhibitors to prevent formulation of rust.	Hook and Latch Pivot Points, Chain	16 oz (.47 L) Spray Bottle 5 gal (18.9 L) Bulk Container
50P 50G 68 8 lb	03875705 03875713 03820016	Detergent free SAE 50W oil with formulation to inhibit the formation of rust. High performance, extreme pressure, multiple purpose lubricating grease.	Chain Upper & Lower Hook Thrust Bearings, Trolley Wheel Bearings & Gear	1 pt (.47 L) 1 gal (3.78 L) 8 lb (3.62 kg) Can
29665	04205936	Detergent free spindle oil with viscosity of 155-165 S.U.S. at 100 deg F and aniline pt of 217 deg F.	Air Line Lubricator	1 qt (.94 L)



Pendent Handles*

Part Number	CPN	Description	Air Inlet Sizes (BSP)
PHS2E	38559233	single motor pendent	1/4"
PHS2E-U	38559258	single motor pendent w/ E-Stop	1/4"
PHS4E	38559274	two motor pendent	1/4"
PHS4E-U	38559290	two motor pendent w/ E-Stop	1/4"

* View parts manual MHD56297 for hose, fittings, etc.

Bulk Load Chains

Bulk Load Chains for LIFTCHAIN® Series

Note: Load chain is corrosion resistant treated as standard (grade 80)

Used on models	Chain Part Number	Chain size Dia x pitch (mm)	Length in meter	Weight per lineal meter	CPN
LC2A015S/030D	LC824-G8ZP	8 x 24	100	1.5	38532172
LCA030S/060D	LC1336-G8ZP	13 x 36	200	3.85	38527677
LCA060S/120D/180T/250Q	LC1645-G8ZP	16 x 45	100	5.75	38527800
LC2A125S to 500Q	LC2266-G8ZP	22 x 66	100	11	38537544

Used on models	Chain Part Number	Chain size Dia x pitch (mm)	Length in meter	Weight per length (kg)	CPN
LC2A015S/030D	LC824-G8ZP-100M	8 x 24	100	150	38756557
LC2A015S/030D	LC824-G8ZP-200M	8 x 24	200	300	38756540
LCA030S/060D	LC1336-G8ZP-100M	13 x 36	100	385	38756508
LCA060S/120D/180T/250Q	LC1645-G8ZP-100M	16 x 45	100	575	38756524
LC2A125S to 500Q	LC2266-G8ZP-100M	22 x 66	100	1,100	38756532

All accessories should be ordered using the corresponding CPN, except for customers within the U.S. and Canada. These customers should use the noted part number.

Service & Accessories

Service Kits

To insure the highest quality repair and reduce repair turnaround time Ingersoll Rand has prepackaged the following kits for the LC2A air chain hoists. Each kit contains all of the necessary parts required to bring a subassembly or complete hoist back to original Ingersoll Rand specifications. Kit contents are defined in the Parts Manual MHD56297.

Model	CPN	P/N	Description
LC2A015S and LC2A030D	38780904	76500089	Brake Repair Kit for 1.5 and 3 ton Single Fall Hoist
LC2A015S and LC2A030D	38780912	76500090	Center Section Repair Kit for 1.5 and 3 Ton Hoist Industrial
LC2A015S and LC2A030D	38780037	76500002	Overhaul Kit for 1.5 and 3 Ton Hoist Industrial Pendant with E-Stop
LC2A015S and LC2A030D	38780029	76500001	Overhaul Kit for 1.5 and 3 Ton Hoist Industrial Pendant w/o E-Stop
LC2A015S to LC2A250Q	38780805	76500079	Rebuild Kit for 2 Lever Pendant w/o E-Stop
LC2A015S to LC2A250Q	38780813	76500080	Rebuild Kit for 2 Lever Pendant with E-Stop
LC2A015S to LC2A250Q	38780821	76500081	Rebuild Kit for 4 Lever Pendant w/o E-Stop
LC2A015S to LC2A250Q	38780839	76500082	Rebuild Kit for 4 Lever Pendant with E-Stop
LC2A015S and LC2A030D	38780938	76500092	Reducer Repair Kit for 1.5 and 3 Ton Hoist
LC2A015S to LC2A250Q	38781423	76500141	Repair Kit for 2 Lever Pendant w/o E-Stop
LC2A015S to LC2A250Q	38781431	76500142	Repair Kit for 2 Lever Pendant with E-Stop
LC2A015S to LC2A250Q	38781928	76500161	Repair Kit for 3.5 and 6 hp Motor
LC2A015S and LC2A030D	38781340	76500133	Repair Kit for 3.5 hp Motor Industrial without E-Stop
LC2A015S and LC2A030D	38781365	76500135	Repair Kit for 3.5 hp Motor Industrial with E-Stop
LC2A015S to LC2A250Q	38792115	76500250	Repair Kit for 3.5 and 6 hp Motor Rope Control w/o E-Stop
LC2A015S to LC2A250Q	38792123	76500251	Repair Kit for 3.5 and 6 hp Motor Rope Control with E-Stop
LC2A015S to LC2A250Q	38781449	76500143	Repair Kit for 4 Lever Pendant w/o E-Stop
LC2A015S to LC2A250Q	38781456	76500144	Repair Kit for 4 Lever Pendant with E-Stop
LC2A040S to LC2A250Q	38791844	76500223	Brake Repair Kit for 4 Ton Single Fall to 25 ton Quad fall
LC2A040S and LC2A80D	38791893	76500228	Center Section Repair Kit for 4 and 8 Ton Hoist Industrial
LC2A040S and LC2A80D	38792008	76500239	Overhaul Kit for 4 and 8 Ton Hoist Industrial Pendant w/o E-stop
LC2A040S and LC2A80D	38792016	76500240	Overhaul Kit for 4 and 8 Ton Hoist Industrial Pendant with E-Stop
LC2A040S to LC2A250Q	38791802	76500219	Repair Kit for 6 hp Motor Industrial w/o E-Stop
LC2A040S to LC2A250Q	38791810	76500220	Repair Kit for 6 hp Motor Industrial with E-Stop
LC2A040S and LC2A80D	38791851	76500224	Reducer Repair Kit for 4 and 8 Ton Hoist
LC2A060S and LC2A120D	38792057	76500244	Overhaul Kit for 6 and 12 Ton Hoist Industrial Pendant w/o E-stop
LC2A060S and LC2A120D	38792065	76500245	Overhaul Kit for 6 and 12 Ton Hoist Industrial Pendant with E-Stop
LC2A060S to LC2A250Q	38791919	76500230	Reducer Repair Kit for 6 to 25 Ton Hoist
LC2A060S and LC2A120D	38791950	76500234	Center Section Repair Kit for 6 and 12 Ton Hoist Industrial
LC2A180T and LC2A250Q	38791984	76500237	Center Section Repair Kit for 18 and 25 Ton Hoist Industrial
LC2A180T and LC2A250Q	38792107	76500249	Overhaul Kit for 18 and 25 Ton Hoist Industrial Pendant with E-Stop
LC2A180T and LC2A250Q	38792099	76500248	Overhaul Kit for 18 and 25 Ton Hoist Industrial Pendant w/o E-Stop

Manuals can be downloaded from www.irtools.com free of charge.

The use of other than genuine Ingersoll Rand replacement parts may result in safety hazards, decreased performance and increased maintenance and may invalidate all warranties.



Service & Accessories

Chain Buckets for Air

Chain Buckets (Check the number of falls to match the height of lift and the bucket capacity)

Part Number/CPN (Option code)	Use on Hoist Series	Corresponding H.O.L.		Lineal Capacity		Chain Container Dimension "X"				Material
		meters	feet	meters	feet	Hook Mount mm	in	Trolley Mount mm	in	
CB2-030D-12M (A) / 38753273	LC2A015S	12	39.3	12	39.3	628	24.7	667	26.3	Canvas
	LC2A030D	6	19.6			657	25.9	712	28.0	
	LC2A060Q	3	9.8			721	28.4	769	30.3	
CB2-030D-30M (B) / 38753281	LC2A015S	30	98.4	30	98.4	728	28.7	767	30.2	Canvas
	LC2A030D	15	49.2			757	29.8	812	32.0	
	LC2A060Q	7.5	24.6			821	32.3	869	34.2	
CB2-030D-60M (C) / 38753299	LC2A015S	60	196.8	60	196.8	828	32.6	867	34.1	Canvas
	LC2A030D	30	98.4			857	33.7	912	35.9	
	LC2A060Q	15	49.2			921	36.3	969	38.1	
CB2-080D-12M (A) / 38794806	LC2A040S	12	39.3	12	39.3	847	33.3	856	33.7	Canvas
	LC2A080D	6	19.6			890	35.0	896	35.3	
CB2-080D-25M (B) / 38794814	LC2A040S	25	82.0	25	82.0	947	37.3	956	37.6	Canvas
	LC2A080D	12	39.3			990	39.0	996	39.2	
CB2-080D-40M (C) / 38794822	LC2A040S	40	131.2	40	131.2	1,107	43.6	1,116	43.9	Metal
	LC2A080D	20	65.6			1,150	45.3	1,156	45.5	
	LC2A060S	12	39.3	12	39.3	1,065	41.9	1,065	41.9	
CB2-120D-12M (A) / 38794830	LC2A120D	6	19.6			1,085	42.7	1,135	44.7	Canvas
	LC2A180T	4	13.1			1,142	45.0	1,273	50.1	
	LC2A250Q	3	9.8			1,189	46.8	1,273	50.1	
	LC2A060S	26	85.3	24	78.7	1,265	49.8	1,265	49.8	
CB2-120D-26M (B) / 38794848	LC2A120D	13	42.6			1,285	50.6	1,335	52.6	Metal
	LC2A180T	8	26.2			1,342	52.8	1,473	58.0	
	LC2A250Q	6	19.6			1,389	54.7	1,473	58.0	
	LC2A060S	40	131.2	40	131.2	1,265	49.8	1,265	49.8	
CB2-120D-40M (C) / 38794855	LC2A120D	20	65.6			1,285	50.6	1,335	52.6	Metal
	LC2A180T	13	42.6			1,342	52.8	1,473	58.0	
	LC2A250Q	10	32.8			1,389	54.7	1,473	58.0	

Chain containers are a simple and economical way of capturing the load chain and preventing it from interfering with the load, hoist control cords, or other objects.

A variety of standard sizes are available and we are always ready to provide quotations for specialty containers for long lifts or where space restrictions may require custom design.



Service & Accessories

Chain Buckets for Hydraulic

3 to 25 Ton Lifting Capacity

Part Number/CPN (Option code)	Use on Hoist Series	Corresponding H.O.L.		Lineal Capacity		Chain Container Dimension "X"				Material
		meters	feet	meters	feet	Hook Mount mm	in	Trolley Mount mm	in	
CB120D-12M (A) / 38558961	LCH060S	12	39.4	12	39.4	1,091	43.0	1,095	43.1	Canvas
	LCH120D	6	19.7			1,125	44.3	1,137	44.8	
	LCH180T	4	13.1			1,169	46.0	1,319	51.9	
	LCH250Q	3	9.8			1,220	48.0	1,319	51.9	
CB120D-26M (B) / 38558979	LCH060S	26	85.3	26	85.3	1,286	50.6	1,290	50.8	Metal
	LCH120D	13	42.6			1,320	52.0	1,332	52.4	
	LCH180T	8.5	27.9			1,364	53.7	1,514	59.6	
	LCH250Q	6.5	21.3			1,415	55.7	1,514	59.6	
CB120D-40M (C) / 38761003	LCH060S	40	131.2	40	131.2	1,286	50.6	1,290	50.8	Metal
	LCH120D	20	65.6			1,320	52.0	1,332	52.4	
	LCH180T	13	42.6			1,364	53.7	1,514	59.6	
	LCH250Q	10	32.8			1,415	55.7	1,514	59.6	

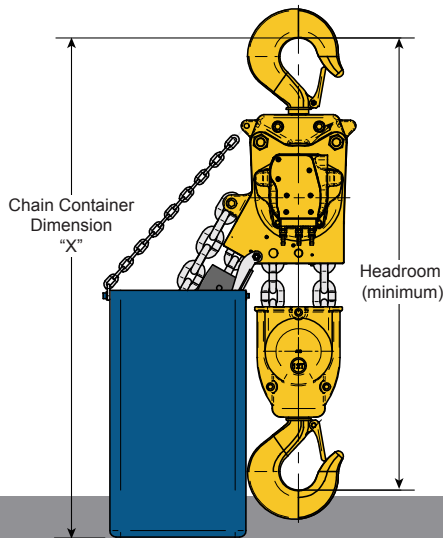

Tip:

Remember that head room is measured from saddle of top hook (or tread line of wheel on trolley mounts) to saddle of bottom hook. Depending on length of lift, and the size of chain container being used, the container may hang lower than the saddle of bottom hook.



Service & Accessories

PT and GT Series Trolley

1/2 – 20 metric ton Capacity

Features

PT plain and GT hand geared hook-on style trolley rated for manual or powered hoists having the versatility to fit most types of beams with compatibility to all hoist brands.

- **The 5:1 design factor allows use with both manual or powered hoists. Meets pertinent U.S. (ASME/ANSI and CMAA), Canadian and European standards.**
- The side plates, including the rail sweeps/drop stops, are made of cold formed steel for strength, durability and even load distribution.
- The wheels are cast iron with the “**Universal**” tread fits either flat or tapered beams.
- Wheels run on sealed, “**Lube-for-Life**” ball bearings. Smoother rolling with less effort and maintenance.

Options:

- **FDA approved nickel composite plated finish** for corrosion resistance.
- Solid Bronze alloy wheels for maximum spark resistance.
- Wider hanger shaft capabilities allow standard trolleys fit almost any S-Beam or patented track beam. **Extension shaft kits are stocked.**
- Additional gearing in the 20 ton trolley allows operation by one hand chain.
- Painted black for “**Universal**” coordination with hoists of all colors.



PT010-8



GT020-8-10



GT100-12-10

PT and GT Hook-On Trolley Specifications

Model No.	Capacity		Standard Flange	Min. Beam	Min. Curve	Weight lbs	Kit no. (Order separate)	Optional Flange	Weight lbs
	tons	lbs	Adjustment in.	Height in.	Radius in.			Adjustment in.	
Standard Series									
PT005-8	1/2	1,100	2.63-8.00	4	36	19.7	PT005-WFK	8-13	5.5
PT010-8	1	2,200	3.00-8.00	5	36	30.7	PT010-WFK	8-13	9.5
GT010-8-10	1	2,200	3.00-8.00	5	36	43.7	PT010-WFK	8-13	9.5
PT020-8	2	4,400	3.32-8.00	6	48	60.5	PT020-WFK	8-13	10
GT020-8-10	2	4,400	3.32-8.00	6	48	73.5	PT020-WFK	8-13	10
PT030-8	3	6,600	3.94-8.00	7	42	73.2	PT030-WFK	8-13	16.3
GT030-8-10	3	6,600	3.94-8.00	7	42	86.2	PT030-WFK	8-13	16.3
PT050-8	5	11,000	4.64-8.00	8	60	110.3	PT050-WFK	8-13	24.8
GT050-8-10	5	11,000	4.64-8.00	8	60	123.3	PT050-WFK	8-13	24.8
PT100-12	10	22,000	7.00-13	10	83	205	NA	NA	NA
GT100-12-10	10	22,000	7.00-13	10	83	227	NA	NA	NA
GT200-12	20	44,000	7.00-13	12	138	540	NA	NA	NA

Service & Accessories

PT and GT Series Trolley

PT and GT Hook-On Trolley Dimensions (in.)

Model no.	A	A(-8)	B	C	D	E	F	G	H	J	K	L	M	N	P	P(-8)	R	S	T
PT005-8	2.63	5.88	10	4.5	1	4	1.13	3.5	2.06	0.75	0.75	6.63	---	3.94	---	12.25	1.25	1.56	---
PT010-8	2.5	5.94	13	5.19	1.25	4.44	1.56	4.19	2.75	0.75	1	6.94	---	4.25	---	12.88	1.5	1.56	---
GT010-8-10	2.5	5.94	13	5.19	1.25	4.44	1.56	4.19	2.75	0.75	1	6.94	---	4.25	---	12.88	1.5	1.56	7.81
PT020-8	2.56	6.06	14.94	6.75	1.25	5.25	1.25	5.81	4.25	1.13	1.19	7.5	---	4.31	---	13.81	1.5	1.56	---
GT020-8-10	2.56	6.06	14.94	6.75	1.25	5.25	1.25	5.81	4.25	1.13	1.19	7.5	---	4.31	---	13.81	1.5	1.56	7.75
PT030-8	2.56	7.88	14	6.38	1.56	5.5	1.56	5.75	4.5	1.13	1.44	8.56	---	5.38	---	14.13	1.94	2.56	---
GT030-8-10	2.56	7.88	14	6.38	1.56	5.5	1.56	5.75	4.5	1.13	1.44	8.56	---	5.38	---	14.13	1.94	2.56	8.06
PT050-8	2.81	8.13	15.5	7.06	1.56	5.75	2.19	6.19	4.5	1.56	1.44	9.81	---	6.63	---	15.63	2.5	2.56	---
GT050-8-10	2.81	8.13	15.5	7.06	1.56	5.75	2.19	6.19	4.5	1.56	1.44	9.81	---	6.63	---	15.63	2.5	2.56	8.5
PT100-12	11.79	---	17.91	19.29	20.79	5.02	7.87	2.00	7.44	5.94	4.21	1.77	3.23	17.09	3.70	---	1.00	---	---
GT100-12-10	11.79	---	17.91	19.29	20.79	5.02	7.87	2.00	7.44	5.94	4.21	1.77	3.23	17.09	3.70	---	1.00	---	---
GT200-12-10	10.47	---	25.28	24.49	22.52	6.73	11.81	2.60	10.79	7.87	5.91	2.76	4.33	18.03	4.49	---	4.92	---	---

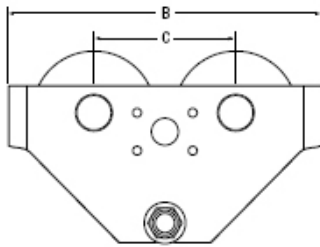

PT010 - PT050
plain trolley / without lug

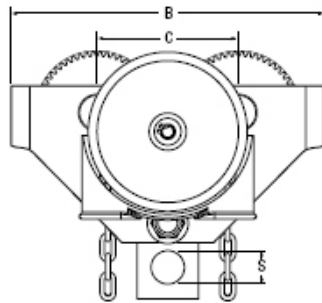

GT010 - GT050
geared trolley

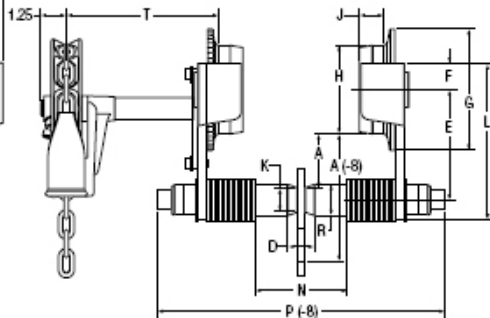

PT010 - PT050 & GT010 - GT050
plain & geared trolley

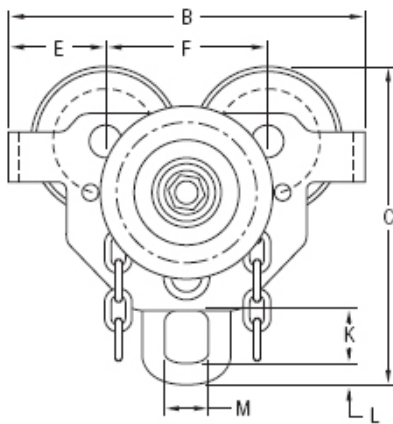

GT100
geared trolley

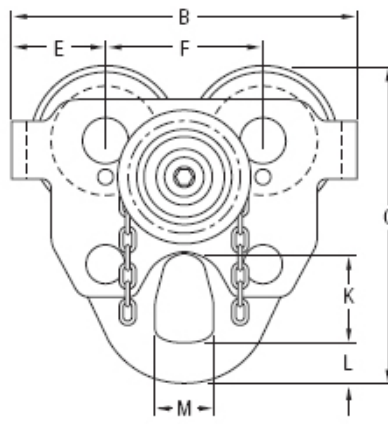

GT200
geared trolley

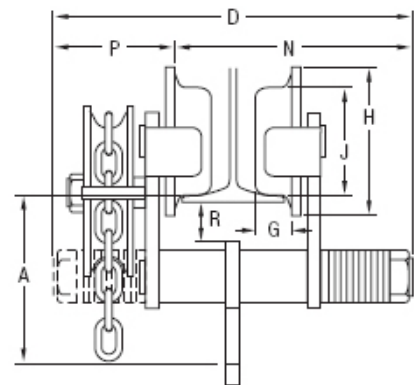

GT100 and GT200
geared trolley

Service & Accessories

Beam Clamps

1 – 10 metric ton Capacity

Beam Clamp features:

Beam Clamps provide a temporary or permanent mount to a wide range of tapered or flat beams. These units have been designed and verified, by actual pull testing, to achieve minimum design factor of 5:1 for vertical lifting with powered or manual hoist meeting ASME B30.16. Quick and simple installation is achieved by hand without tools. Units accommodate hook-mounted hoist or load blocks with minimal loss of headroom. The clamp jaws are designed to reduce beam stress by applying the load inside of the flange edge.

- Quick installation by hand.
- Low headroom design adjust to fit a wide range of flat or tapered beams.
- Meets ASME B30.16 for use with powered or manual hoists.
- Each unit is serialized, supplied with a test certificate and manual.
- Metric rated for vertical lifting at 2,200 lbs per ton.



BC Series Beam Clamp specifications and dimensions (in.)

Model no.	Capacity metric tons	Weight lbs	Beam width						
			A	B	C	D	E	F	
BC-1	1	4	2 ¹⁵ / ₁₆ - 9 ¹ / ₁₆	3 ³ / ₁₆	8 ³ / ₄	4 - 6 ⁵ / ₁₆	1 ¹ / ₈	¹³ / ₁₆	
BC-2	2	5	2 ¹⁵ / ₁₆ - 9 ¹ / ₁₆	3 ⁵ / ₈	8 ³ / ₄	4 - 6 ⁵ / ₁₆	1 ¹ / ₈	⁷ / ₈	
BC-3	3	9	3 ⁵ / ₃₂ - 12 ⁵ / ₈	4 ⁵ / ₈	10 ³ / ₄	6 ⁵ / ₈ - 9 ¹ / ₂	2 ⁷ / ₁₆	¹⁵ / ₁₆	
BC-5	5	11	3 ⁹ / ₁₆ - 12 ⁵ / ₈	4 ¹³ / ₁₆	10 ³ / ₄	6 ⁵ / ₈ - 9 ¹ / ₂	2 ³ / ₈	1 ³ / ₁₆	
BC-10	10	11	3 ⁹ / ₁₆ - 14 ³ / ₈	5 ¹⁵ / ₁₆	11 ¹ / ₆₄	6 ¹¹ / ₁₆ - 9 ¹ / ₄	1 ³¹ / ₃₂	1 ³⁷ / ₆₄	

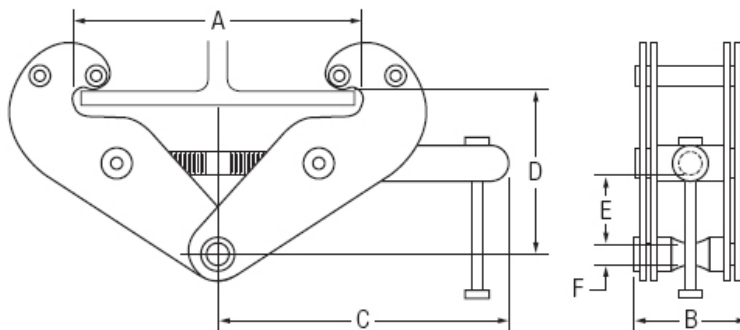

Solutions

Special Orders

A significant portion of our business is providing customized solutions for specific applications. We recognize that not all jobs are created equal and that the most cost-effective solutions may not be in an off-the-shelf item. We've designed and manufactured winches and hoists for applications as simple as moving bags of lettuce, to as intricate as installing critical payloads on space vehicles.



Custom Levelwinds



ASME NUM1 Critical Load Handling Hoists



Electric Chain Hoists For Explosion Proof Environments



Waterfall Winch Systems



Electric Man Rider™ Winches



Clean Room Hoists