



Palăng xích lắc tay

Dòng SLB Silver



For when you really need a lift

Ingersoll Rand SLB Silver Series lever hoists offer the ultimate in performance, durability, and safety for a variety of demanding applications. The high-strength, all-stamped steel construction offers decreased weight and better impact resistance. The automatic inertia brake engages if load is applied in free-chain mode, helping minimize operator setup error.



Double chain guides for proper load chain tracking and smooth operation around load sheave

CE Certified; hoists meet or exceed regional requirements including ASMEB30.21, HST-3M

Open frame design for easy cleaning and inspection

Encased and retained roller bearings for increased efficiency and ease of maintenance

Premium grade alloy load chain

Hardened swivel-latch hooks

Nickel / chrome-plated exterior and zinc-plated frame components for increased corrosion resistance

Double reduction gearing for superior spotting characteristics and low handle effort

Deep lug knobs for easy one-handed operation with or without gloves

Short handle and stroke allows 360-degree operation for rigging in tight spaces



SLB Silver Series lever hoists are ideal for these applications:

- Offshore drilling rigs
- Oil refineries and chemical plants
- Shipbuilding and shipyards
- Mining
- Utilities
- Steel mills and foundries
- General construction
- Maintenance and repairs
- Rigging

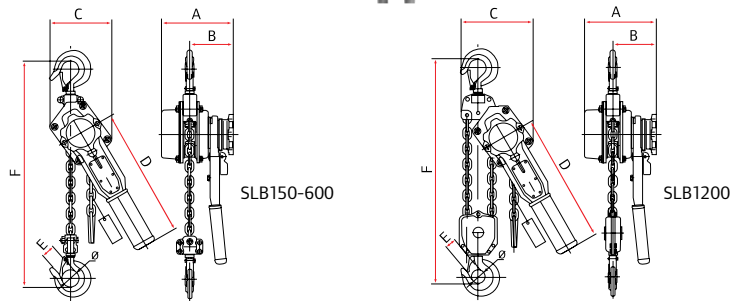

MODEL	RATED CAPACITY		PULL TO LIFT RATED LOAD	NO. OF CHAIN FALLS	A	B	C	D	E	F (min)	Ø	LOAD CHAIN SIZE
	Metric tons	(lb)			mm (in)	mm (in)	mm (in)	mm (in)	mm (in)	mm (in)	mm (in)	mm (in)
SLB150	3/4	(1,650)	41	1	158 (6.2)	93 (3.6)	132 (5.2)	308 (12.1)	29 (1.1)	330 (13)	37 (1.5)	6 X 18 (0.24 x 0.71)
SLB200	1	(2,200)	60	1	163 (6.4)	95 (3.7)	140 (5.5)	308 (12.1)	32 (1.3)	365 (14.4)	40 (1.6)	6 X 18 (0.24 x 0.71)
SLB300	1-1/2	(3,300)	53	1	185 (7.3)	106 (4.2)	145 (5.7)	378 (14.9)	35 (1.4)	400 (15.7)	45 (1.8)	7.1 x 21.2 (0.28 x 0.84)
SLB600	3	(6,600)	53	1	212 (8.4)	118 (4.6)	199 (7.8)	418 (16.5)	44 (1.7)	520 (20.5)	55 (2.2)	10 x 30 (0.39 x 1.18)
SLB1200	6	(13,200)	57	2	212 (8.4)	118 (4.6)	230 (9.1)	418 (16.5)	50 (2)	640 (25.2)	65 (2.6)	10 x 30 (0.39 x 1.18)

Distributed by:

