



**IR** Ingersoll Rand<sup>®</sup>  
Engine Starting Systems



# Index

## Engine Starting Systems Index

Category	Sub-Sections	Page #
<b>Air Starter Selection Guide</b>		<b>i</b>
<b>Warranty</b>		<b>ii</b>
<b>150T™ “F” Series</b>		<b>A-1 to A-6</b>
	Features/Benefits	A-1
	Dimensions	A-2
	Performance Information	A-2
	Model Numbers	A-3
	Accessories	A-4
	Installations	A-5
	Engine Selection Guide	A-6
<b>ST500 Series</b>		<b>B-1 to B-6</b>
	Features/Benefits	B-1
	Dimensions	B-2
	Performance Information	B-3
	Replacement Kits	B-4
	Accessories	B-4
	Installations	B-5
	Model Numbers	B-6
	Engine Selection Guide	B-6
<b>ST600 Series</b>		<b>C-1 to C-6</b>
	Features/Benefits	C-1
	Dimensions	C-2
	Performance Information	C-3
	Replacement Kits	C-4
	Accessories	C-4
	Installations	C-5
	Model Numbers	C-6
	Engine Selection Guide	C-6
<b>ST700/ST900 Series</b>		<b>D-1 to D-10</b>
	Features/Benefits	D-1
	Dimensions	D-2
	Performance Information	D-3
	Accessories	D-4
	Installations	D-5, D-6, D-7
	Model Numbers	D-7
	Engine Selection Guide	D-8
	Replacement Kits	D-9, D-10
<b>3BMG/5BMG Series</b>		<b>E-1 to E-8</b>
	Features/Benefits	E-1
	Dimensions	E-2
	Performance Information	E-3
	Accessories	E-4
	Installations	E-5
	Model Numbers	E-6
	Engine Selection Guide	E-7
	Replacement Kits	E-8

Category	Sub-Sections	Page #
<b>SS175/SS350 Series</b>		<b>F-1 to F-8</b>
	Features/Benefits	F-1
	Dimensions	F-2
	Performance Information	F-3
	Accessories	F-4
	Installations	F-5
	Model Numbers	F-6
	Engine Selection Guide	F-7
	Replacement Kits	F-8
<b>150BM Series</b>		<b>G-1 to G-8</b>
	Features/Benefits	G-1
	Dimensions	G-2
	Performance Information	G-3
	Accessories	G-4
	Installations	G-5
	Model Numbers	G-6
	Engine Selection Guide	G-7
	Replacement Kits	G-8
<b>SS800 Series</b>		<b>H-1 to H-8</b>
	Features/Benefits	H-1
	Dimensions	H-2
	Performance Information	H-3
	Accessories	H-4
	Installations	H-5
	Model Numbers	H-6
	Engine Selection Guide	H-7
	Replacement Kits	H-8
<b>TS700/TS900/TS1400 Series</b>		<b>I-1 to I-8</b>
	Features/Benefits	I-1
	Dimensions	I-3, I-5
	Performance Information	I-6
	Engine Selection Guide	I-7
	Replacement Kits	I-8
	Accessories	I-8
<b>Accessories</b>		<b>J-1 to J-18</b>
	Accessories Index	J-1, J-2
	Relay Valves	J-3, J-4
	Solenoid Control Valves	J-5, J-6
	Push Button Control Valves	J-7
	Air Strainers	J-8, J-9
	Mufflers	J-10
	Regulators	J-11, J-12
	In-Line Lubricators	J-13, J-14
	One-Shot Lubricators	J-15
	Road Splash Deflectors	J-16
	Exhaust Tube Kit	J-16
	Liquid Sealants	J-16
	Check Valves	J-17
	Drain Valves	J-17
	Gladhand Couplings	J-18
	Pressure Gauges	J-18

Note: All dimensions shown are for reference only. Specifications subject to change without notice.  
 Note: The number of starts per tank is based on theoretical calculations. The actual number of starts depends on engine size, temperature, air pressure, and starting characteristics of the engine.

**IR Locations**

**inside back cover**

# Air Starter Selection Guide

## Lubrication Free Selection Guide (Turbine Motor)

For Diesel Engine Displacement (liters)	Catalog Section	Series	Gear Ratio	Extended Starting Capability (>10 sec.)	Max Power (HP)	Max Pressure (psig)	Air Consumption at Max HP – SCFM (L/s)	Engagement Type**	Inlet Size (NPT)	Exhaust Size (NPT)	Gas Sealed
8 to 27	A	150TMG	F	Yes	28	150	710 (335)	Inertia	1¼"	2"	Yes
8 to 27	A	150TMP	F	Yes	28	150	710 (335)	Pre-Engaged	1¼"	2"	Yes
8 to 27	A	150TLP	F	Yes	28	90	780 (368)	Pre-Engaged	1¼"	2"	Yes
5 to 100	B	ST599	F	Yes	44	150	1240 (585)	Pre-Engaged	1¼"	2"	Yes
5 to 100	B	ST544	F	Yes	28	150	710 (335)	Pre-Engaged	1¼"	2"	Yes
16 to 80	C	ST650	B	Yes	66	150	1450 (684)	Pre-Engaged	1¼"	5" V-Band Flange	No
16 to 80	C	ST699	B	Yes	67	90	1700 (802)	Pre-Engaged	1½"	5" V-Band Flange	No
16 to 130	D	ST750	B	No	55	150	1300 (614)	Inertia/ Pre-engaged	1½"	4" *	Yes
16 to 130	D	ST799	B	No	66	90	1700 (802)	Inertia/ Pre-engaged	1½"	4" *	Yes
80 to 200	D	ST750	C	No	55	150	1300 (614)	Pre-Engaged	1½"	4" *	Yes
80 to 200	D	ST799	C	No	66	90	1700 (802)	Pre-Engaged	1½"	4" *	Yes
160 to 320	D	ST750	D	No	55	150	1300 (614)	Pre-Engaged	1½"	4" *	Yes
160 to 320	D	ST799	D	No	66	90	1700 (802)	Pre-Engaged	1½"	4" *	Yes
16 to 130	D	ST950	B	Yes	55	150	1300 (614)	Inertia/ Pre-engaged	1½"	4" *	Yes
16 to 130	D	ST999	B	Yes	66	90	1700 (802)	Inertia/ Pre-engaged	1½"	4" *	Yes
80 to 200	D	ST950	C	Yes	55	150	1300 (614)	Pre-Engaged	1½"	4" *	Yes
80 to 200	D	ST999	C	Yes	66	90	1700 (802)	Pre-Engaged	1½"	4" *	Yes
160 to 320	D	ST950	D	Yes	55	150	1300 (614)	Pre-Engaged	1½"	4" *	Yes
160 to 320	D	ST999	D	Yes	66	90	1700 (802)	Pre-Engaged	1½"	4" *	Yes
Gas Turbine Engines	I	TS700/ TS900	D	Yes	130	225	2200 (1038)	Permanently Engaged	1½"	4" *	Yes

\* Or exhaust through a welded flanged 3½" schedule 40 pipe.

## External Lubrication Required Selection Guide (Vane Motor)

For Diesel Engine Displacement (liters)	Catalog Section	Series	Gear Ratio	Extended Starting Capability (>10 sec.)	Max Power (HP)	Max Pressure (psig)	Air Consumption at Max HP – SCFM (L/s)	Engagement Type**	Inlet Size (NPT)	Exhaust Size (NPT)	Gas Sealed
0 to 5	E	3BMG	Direct	No	8	150	325 (153)	Inertia	¾"	1"	Yes
3 to 8	E	5BMG	Direct	No	10	150	310 (146)	Inertia	¾"	1"	Yes
3 to 8	F	SS175G	B	No	18	150	500 (236)	Pre-Engaged	1"	1¼"	Yes
5 to 10	F	SS175G	E	No	18	150	500 (236)	Pre-Engaged	1"	1¼"	Yes
8 to 27	G	150BMG	E	No	32	150	680 (321)	Pre-Engaged	1¼"	1¼"	Yes
8 to 27	G	150BMP	E	No	32	150	680 (321)	Pre-Engaged	1¼"	1¼"	No
15 to 32	G	150BMP	D	No	32	150	680 (321)	Pre-Engaged	1¼"	1¼"	No
8 to 27	F	SS350G	E	No	36	150	900 (425)	Pre-Engaged	1¼"	1½"	Yes
16 to 130	H	SS810	B	No	80	150	1700 (802)	Inertia	1½"	2½"	Yes
16 to 130	H	SS815	B	No	80	150	1700 (802)	Pre-Engaged	1½"	2½"	Yes
80 to 200	H	SS825	C	No	75	150	1350 (637)	Pre-Engaged	1½"	2½"	Yes
160 to 320	H	SS850	D	No	75	150	1275 (602)	Pre-Engaged	1½"	2½"	Yes

These figures are only a guide. For difficult to start engines or for operation under adverse conditions, use the next more powerful starter. For 2-stroke diesel engines, these figures may be multiplied by 1.5. Ex: a 3BMG could be used in a 7.5 – 2 Stroke diesel engine. For Carbureted (Gas) engines, these figures may be doubled. Ex: a 150BMP could be used on a 40 liter gasoline engine. Note 1 liter = 61.02 in<sup>3</sup>.

\*\* There are two basic types of air starters: pre-engaged and inertia. With pre-engaged starters, the drive pinion is completely engaged with the engine ring gear before the starter begins to crank the engine. With an inertia starter, the rotating drive pinion engages the engine ring gear simultaneously with the initial cranking of the engine.

# Warranty

## AIR STARTER LIMITED WARRANTY

Ingersoll-Rand Company (IR) warrants to the original user its air starters (Starters) to be free of defects in material and workmanship for a period of one year from the date of purchase. IR will repair, without cost, any Starter found to be defective, including parts and labor charges, or at its option, will replace such Starters or refund the purchase price less a reasonable allowance for depreciation, in exchange for the Starter. Repair or replacements are warranted for the remainder of the original warranty period. If any Starter proves defective within its original one-year warranty period, it should be returned to any Authorized Air Starter Service Distributor, transportation prepaid with proof of purchase or warranty card. This warranty does not apply to Starter which IR has determined to have been misused or abused, improperly maintained by the user, or where the malfunction or defect can be attributed to the use of non-genuine IR repair parts.

IR MAKES NO OTHER WARRANTY, AND ALL IMPLIED WARRANTIES INCLUDING ANY WARRANTY OF MERCHANTABILITY OR FITNESS FOR A PARTICULAR PURPOSE ARE LIMITED TO THE DURATION OF THE EXPRESSED WARRANTY PERIOD AS SET FORTH ABOVE. IR's MAXIMUM LIABILITY IS LIMITED TO THE PURCHASE PRICE OF THE STARTER AND IN NO EVENT SHALL IR BE LIABLE FOR ANY CONSEQUENTIAL, INDIRECT, INCIDENTAL, OR SPECIAL DAMAGES OF ANY NATURE ARISING FROM THE SALE OR USE OF THE STARTER, WHETHER IN CONTRACT, TORT, OR OTHERWISE. **NOTE:** Some states do not allow limitations on incidental or consequential damages or how long an implied warranty lasts so that the above limitations may not apply to you. This warranty gives you specific legal rights and you may also have other rights which may vary from state to state.

Other warranties applicable based on product and/or specific applications.

## UNITED STATES AND INTERNATIONAL CERTIFICATIONS

ISO 9001:2000

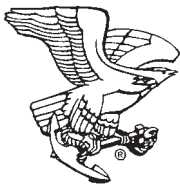

**ABS**

ABS (American Bureau of Shipping)

Lloyds Register

Germanischer Lloyd ([www.germanlloyd.org](http://www.germanlloyd.org))



Korean Register of Shipping



**Germanischer Lloyd**

*Certificate information available upon request.*



## Air Starters

# 150T™ “F” Series



**For engine displacement of:** Diesel–300 to 3600 CID (5 to 60 liters)  
Carburated–1000 to 7200 CID (16 to 120 liters)\*

### Features/Benefits

- Provides 35% more output torque than 150T™ “E” Series Model
- Same inlet and outlet locations as the 150BM and 150T™ “E” Series starters for easy change-out
- Uses the proven front end of the 150BM starter
- Provides maintenance-free operation
- Sealed for use in gas and air applications
- Efficient 30 hp turbine motor uses no external lubrication

### Versatile

- Inertia and pre-engaged models available
- Left- and right-hand rotation available
- 4 inlet, 4 exhaust, and 16 drive housing orientations
- 30-150 psi (2.1-10.3 bars) operation

\* These values may vary depending on engine-specific parasitic loads.



Industry applications ideal for the 150T Series starters: marine, trucking, transit, oil and gas.



## 150T™ "F" Series DIMENSIONS

Weight lbs (kg)	
150T	35 (15.9)

Note: All dimensions shown are for reference only. Specifications subject to change without notice.

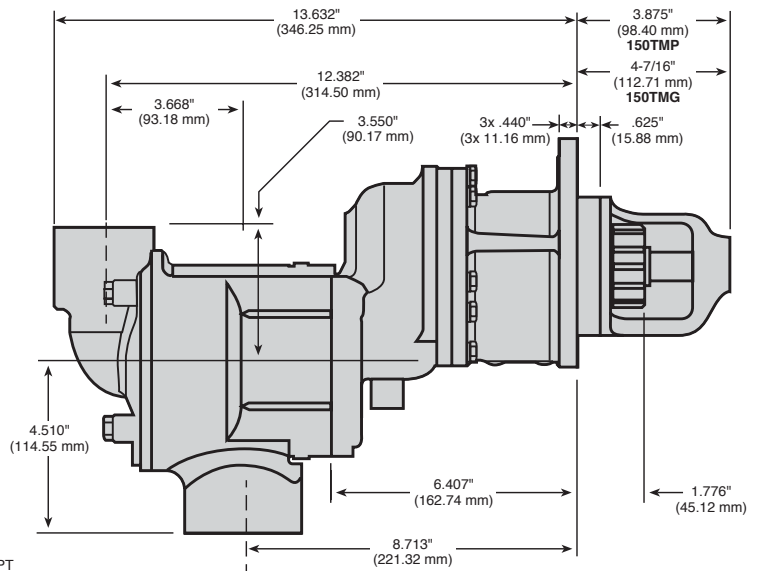
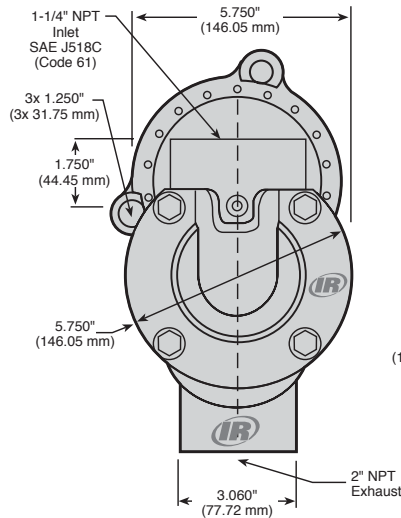

### 150TMPF/150TMGF Performance Information – 44% Arc

Pressure PSI (bar)	Breakaway Torque ft-lb (Nm)	Speed @ Max HP RPM	Max Power HP (kw)	Flow @ Max HP SCFM (L/s)
60 (4.1)	74 (100)	1296	9 (7)	310 (146)
90 (6.2)	113 (153)	1480	16 (12)	430 (203)
120 (8.3)	147 (200)	1580	22 (17)	570 (269)
150 (10.3)	182 (247)	1620	28 (21)	710 (335)

### 150TLPF Performance Information – 99% Arc

Pressure PSI (bar)	Breakaway Torque ft-lb (Nm)	Speed @ Max HP RPM	Max Power HP (kw)	Flow @ Max HP SCFM (L/s)
30 (2.1)	72 (98)	1185	8 (6)	340 (160)
60 (4.1)	132 (179)	1500	19 (14)	580 (274)
90 (6.2)	206 (280)	1530	30 (23)	780 (368)

### 150T™ "F" Series Number of Starts per Tank

(Data taken from crank tests on Detroit Diesel Series 50 with an Allison Transmission)

Max Tank Pressure (psi)	Tank Size									Max Tank Pressure (bar)
	40	60	80	100	120	140	160	180		
300	19	28	37	47	56	65	75	84	20	
270	16	24	33	41	49	57	65	73	18	
240	14	21	28	35	42	49	56	63	16	
210	12	17	23	29	35	41	47	52	14	
180	9	14	19	23	28	33	37	42	12	
150	7	10	14	17	21	24	28	31	10	
120	5	8	9	12	14	16	19	21	8	
90	2	3	5	6	7	8	9	10	6	
	40	60	80	100	120	140	160	180		
	151	227	302	378	454	529	605	680		

**Gallons  
Liters**

# 150T™ “F” Series

*Bold Model Numbers indicate that a remanufactured model is available with the same part number (add an “R” to the number).*

**Most Obsolete Units ▶**

## 150T™ “F” Series Crossover Model Numbers

150T™ “F” Available Units	150BM Crossovers	150LF Crossovers	150BM Obsolete	150BM Obsolete	10BM Obsolete	9BM Obsolete
150TMF21RH-31	150BME21RH-31			101BMPC78RH-31	10BMB21RH-31	
150TMGF12RH-13	150BMGE12RH-13			150BME12RH-13	10BMB12RH-13	9BMA43RH-13
<b>150TMGF21LH-11</b>	150BMGE21LH-11	150LFGE21LH11-000	150BME21LH-11		10BMB21LH-11	9BMB31LH-11
<b>150TMGF21LH-11</b>	150BMGE21LH-11				10BMB22LH-8	9BMA32LH-8
150TMGF21LH-32	150BMGE21LH-32					
<b>150TMGF21RH-6</b>	150BMGE21RH-6	150LFE21RH6-020	150BME21RH-6		10BMB21RH-6	9BMA331RH-6
150TMGF21RH6-22R	150BMGE21RH6-22R	150LFGE21RH6-000	150BME21RH-17			
<b>150TMGF22RH-5</b>	150BMGE22RH-5	150LFGE22RH5-020	150BME22RH-5			
150TMGF22RH5-10D	150BMGE22RH5-10D		150BMGE22RH-5		10BMB12RH-13	9BMA43RH-13
<b>150TMPF88L54-020</b>	150BMPD88L54-020					
<b>150TMPF88R54-020</b>	150BMPD88R54-020		150BMPD88R-46	150BMPD89RH-46	150BMPAC03R85	
150TMPF81R15-00N	150BMPE81R15-00N	150LFPE81R15-020				
150TMPF88L54-11A	150BMPE88L54-11A			150BMPD89LH-50	101BMPC78LH-11	
150TMPF88L54-12E	150BMPE88L54-12E		150BMPE88L-11	150BMPE78LH-11		
150TMPF88L54-13E	150BMPE88L54-13E		150BMPE88L-11	150BMPE83LH-11	10BMB21LH-11	9BMB31LH-11
150TMPF88L54-200	150BMPE88L54-200	150LFPE88L54-000				
150TMPF88L54-20N	150BMPE88L54-20N					
150TMPF88L54-22N	150BMPE88L54-22N					
150TMPF88L54-33A	150BMPE88L54-33A					
150TMPF88L54-33C	150BMPE88L54-33C					
150TMPF88R51-200	150BMPE88R51-200	150LFPE88R51-020				
150TMPF88R53-000	150BMPE88R53-000		150BMPE88R-53	150BMPE78RH-53	101BMPC78RH-38	
150TMPF88R53-020	150BMPE88R53-020	150LFPE88R53-020	150BMPE88R-53	150BMPE78RH-5	10BMB22RH-5	9BMA32RH-5
150TMPF88R53-12F	150BMPE88R53-12F					
150TMPF88R53-200	150BMPE88R53-200					
150TMPF88R53-300	150BMPE88R53-300					
150TMPF88R54-000	150BMPE88R54-000	150LFPE88R54-000	150BMPE88R-44	150BMPE78RH-44	101BMPB78RH-44	
150TMPF88R54-00N	150BMPE88R54-00N	150LFPE88R54-00N	150BMPE88R-54	150BMPE78RH-54		
150TMPF88R54-02E	150BMPE88R54-02E	150LFPE88R54-02E		150BMPE78RH-6	101BMPC78RH-6	
150TMPF88R54-12C	150BMPE88R54-12C					
150TMPF88R54-12D	150BMPE88R54-12D	150LFPE88R54-12D				
150TMPF88R54-12E	150BMPE88R54-12E	150LFPE88R54-12E				
150TMPF88R54-200	150BMPE88R54-200	150LFPE88R54-200				
150TMPF88R54-20E	150BMPE88R54-20E					
150TMPF88R54-220	150BMPE88R54-220					
150TMPF88R54-22E	150BMPE88R54-22E					
150TMPF88R54-300	150BMPE88R54-300	150LFPE88R54-300				
150TMPF88R54-32P	150BMPE88R54-32P					
150TMPF88R54-POS	150BMPE88R54-POS					

### Simple Crossover:

Current 150BM models are superseded to the 150T™ “F” models by replacing the “B” with a “T” AND the “E” with an “F”

**Example:** 150**B**MPE88R54 = 150**T**MP**F**88R54

For low pressure applications (less than 90 psi or 6.2 bar) replace the “M” with an “L”

**Example:** 150**T**M**P**E88R54 = 150**T**LP**F**88R54





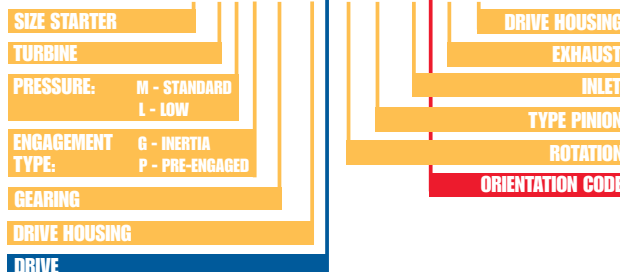

### 150T™ “F” SERIES MODEL CODING

150 T M G F 21 RH 6 0 2 F



## 150T™ “F” Series Accessories

See catalog pages J-1 to J-18 for detailed Accessory information.

IR Part #	Description	Picture
<b>1</b> ST500-674 or 150T-311	2" Muffler	
<b>2</b> 150BMP-1051B	1/4" 12 V Solenoid Valve	
<b>3</b> 150BMP-2451B	1/4" 24 V Solenoid Valve	
<b>4</b> SMB-618	Push Button Valve	
<b>5</b> SMB-G618	Gas Rated Push Button Valve	
<b>6</b> SRV125F	1-1/4" Relay/Solenoid Valve For Transit New builds	
<b>7</b> SRV125T	1-1/4" Relay Valve For Transit Aftermarket	
<b>8</b> SRV125	1-1/4" Relay Valve For Stationary Air	
<b>9</b> SRV150SS	1-1/2" Gas Rated Relay Valve	

IR Part #	Description	Picture
<b>10</b> 150BMP-1058	Gladhand	
<b>11</b> 150BMP-1064	1/8", 150 psi Pressure Gauge	
<b>12</b> ST900-267-24	1-1/2" Strainer (300 Mesh)	
<b>13</b> ST900-266-24	1-1/2" Strainer Element (300 Mesh)	
<b>14</b> ST500-A735	2" Road Splash Deflector	
<b>15</b> 150BMP-1056	1/2" Check Valve	
<b>16</b> 150BMP-1067	1/2" Drain Valve	
<b>17</b> ST500-K166	SAE J518 Split Flange	
<b>18</b> ST500-K740	Exhaust Tube Kit	
<b>19</b> 60RS26-1	Flanged 60-gallon tank; 26" O.D.	

Red item numbers correspond to numbers in diagrams on page A-4.

## 150T™ “F” Series Genuine Ingersoll-Rand Replacement Kits

Tune Up Kit Part Number	Description
150TMP-TK1	150T Pre-engaged Starter Tune Up Kit
150TMG-TK1	150T Inertia Starter Tune Up Kit



150TMP-TK1 Parts



150TMG-TK1 Parts

## 150T™ Series Motor Modules

Motor Module Part Number	Description
150TMFR-100	RH Half Arc Motor Module
150TMFL-100	LH Half Arc Motor Module
150TLFR-100	RH Full Arc Motor Module
150TLFL-100	LH Full Arc Motor Module

Note: The motor module can be used to convert an E ratio to an F ratio 150T starter and includes the motor and the gearing section.



# 150T™ “F” Series

### 150T (Gas) Stationary Installation

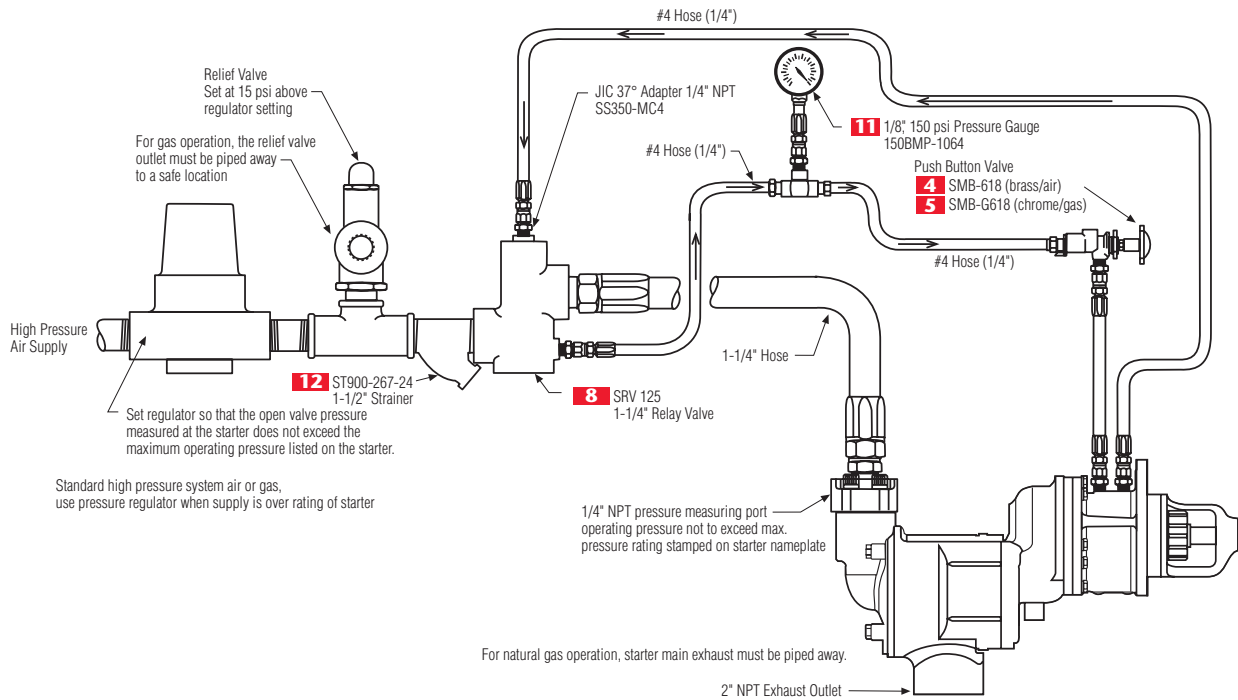

### 150T Typical Vehicular Installation

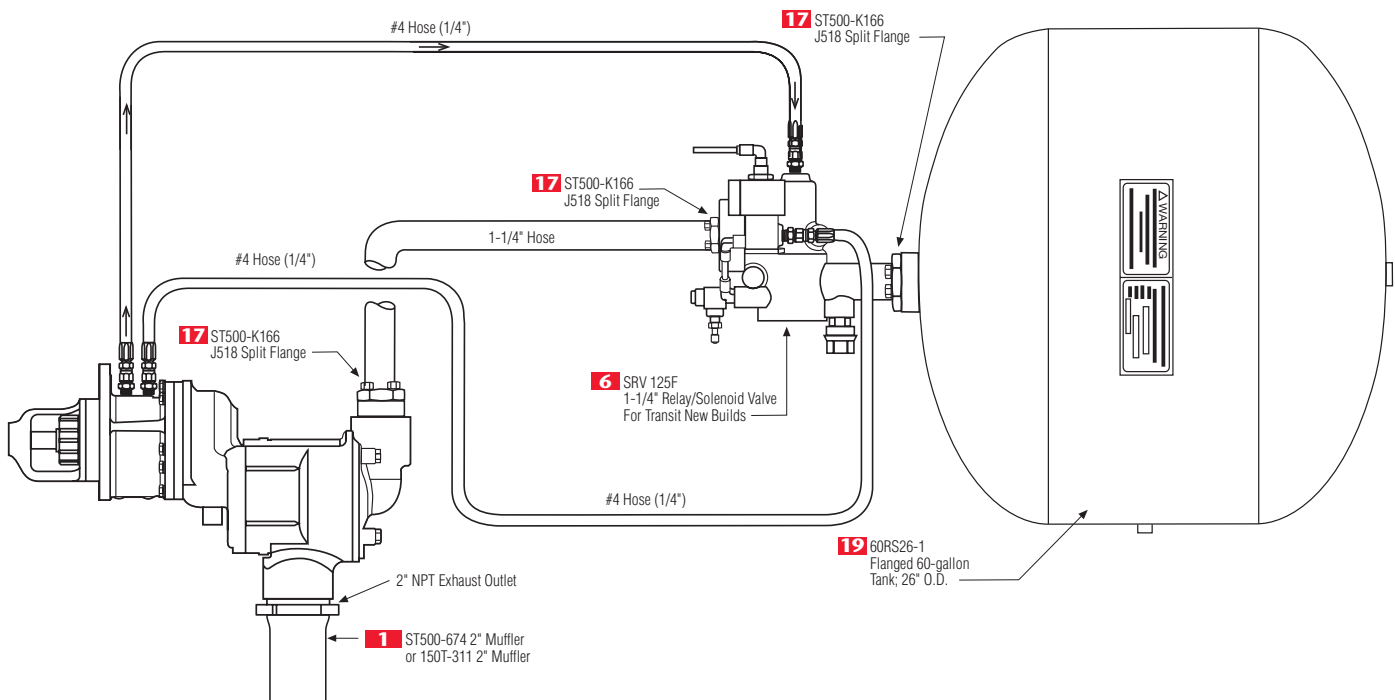



## Series 150T Air Starters

*This chart is a condensed list of engines that can be cranked with an IR starter. For a complete list, please contact IR.*

### 150T™ “F” Series Engine Selection Guide

Manufacturer	Engine	CID	Liter	CYL	Type	Turbine Starter
<b>CATERPILLAR</b>	3126	439	7.2	6	Diesel	150TMPF81R15
	3176	629	10.3	8	Diesel	150TMPF88R54
	3406	893	14.6	6	Diesel	150TMPF88R54
	3408	1099	18	8	Diesel	150TMPF88R54
	D-334	638	10.5	6	Diesel	150TMPF88R53
	D-336	700	11.5	8	Diesel	150TMPF88R53
	D-343	893	14.6	6	Diesel	150TMPF88R54
	D-346	1191	19.5	8	Diesel	150TMPF88R54
	G-342	1246	20.4	6	Nat. Gas	150TMPF88R54
<b>CES-AJAX</b>	DP125	2205	36.1	1	Nat. Gas	150TMGF21LH-11
	DP165	2826	46.3	1	Nat. Gas	150TMGF21LH-11
	DPC180	2826	46.3	1	Nat. Gas	150TMGF21LH-11
	DPC60	850	14	1	Nat. Gas	150TMGF21LH-11
<b>CLIMAX</b>	K67	1616	26.5	6	Gas	150TMPF88R53
	K75	1855	30.4	6	Gas	150TMPF88R53
	R165	1238	20.3	6	Gas	150TMPF88R53
<b>CONTINENTAL</b>	R602	602	9.9	6	Gas	150TMPF88R53
	R6513	513	8.4	6	Gas	150TMPF88R53
	U6501	501	8.2	6	Gas	150TMPF88R53
<b>CUMMINS</b>	ISC	506	8.3	6	Diesel	150TMPF88R53
	ISL	549	9	6	Diesel	150TMPF88R53
	ISM	660	10.8	6	Diesel	150TMPF88R54
	QSK19	1150	19	6	Diesel	150TMPF88R54
	ISM	659	10.8	6	Diesel	150TMPF88R54
	ISX	915	15	6	Diesel	150TMPF88R54
<b>DETROIT DIESEL</b>	6V-71	426	7	6	Diesel	150TMGF21RH6
	6V-92	552	9	6	Diesel	150TMGF21RH6
	Series 50	519	8.5	4	Diesel	150TMPF88R54
	Series 60	778	12.7	6	Diesel	150TMPF88R54
<b>EMD GM</b>	12-645	7740	126.8	12	Diesel	2-150TMPF88R54
	12-710	8520	139.6	12	Diesel	2-150TMPF88R54
	16-645	10320	169.1	16	Diesel	2-150TMPF88R54
	16-710	11360	186.2	16	Diesel	2-150TMPF88R54
	20-645	12900	211.4	20	Diesel	2-150TMPF88R54
	20-710	14200	232.7	20	Diesel	2-150TMPF88R54
	8-645	5160	84.6	8	Diesel	150TMPF88R54
	8-710	5680	93.1	8	Diesel	150TMPF88R54
<b>WAUKESHA</b>	145GZ	817	13.4	6	Nat. Gas	150TMGF22RH5
	6GAK	784	12.8	6	Nat. Gas	150TMGF22RH5
	6WAK	1197	19.6	6	Nat. Gas	150TMGF21RH6
	F1197G	1197	19.6	6	Nat. Gas	150TMGF21RH6
	F119G	1197	19.6	6	Nat. Gas	150TMGF21RH-6
	H1077G	1077	17.6	8	Nat. Gas	150TMGF21RH6
	H24L	1462	24	8	Nat. Gas	150TMGF21RH6
	H867D	866	14.2	8	Diesel	150TMPF88R53
<b>WHITE ENGINES</b>	DFXD	855	14	6	Diesel	150TMPF88R54
	DFXE	895	14.7	6	Diesel	150TMPF88R54



## Air Starters

# ST500 Series



**For engine displacement of:** Diesel–300 to 6,000 CID (5 to 100 liters)  
Carburated–600 to 12,000 CID (10 to 200 liters)

### Features/Benefits

- Powerful 44 hp turbine motor uses no external lubrication
- Splined output shaft allows for smooth torque transmission
- Sealed for air and gas applications
- Steel insert at inlet ensures a solid connection
- Smooth pre-engagement piston minimizes ring gear wear

### Versatile

- Left- or right-hand rotation available
- 30-150 (2.1-10.3 bars) psi operation
- Optional pinions and flanges for any engine



*Industry applications ideal for the ST500 Series starters: oil and gas, marine, power-gen, and transportation.*



## ST500 Series DIMENSIONS

### Weight lbs (kg)

ST500	38 (17.2)
-------	-----------

Note: All dimensions shown are for reference only. Specifications subject to change without notice.

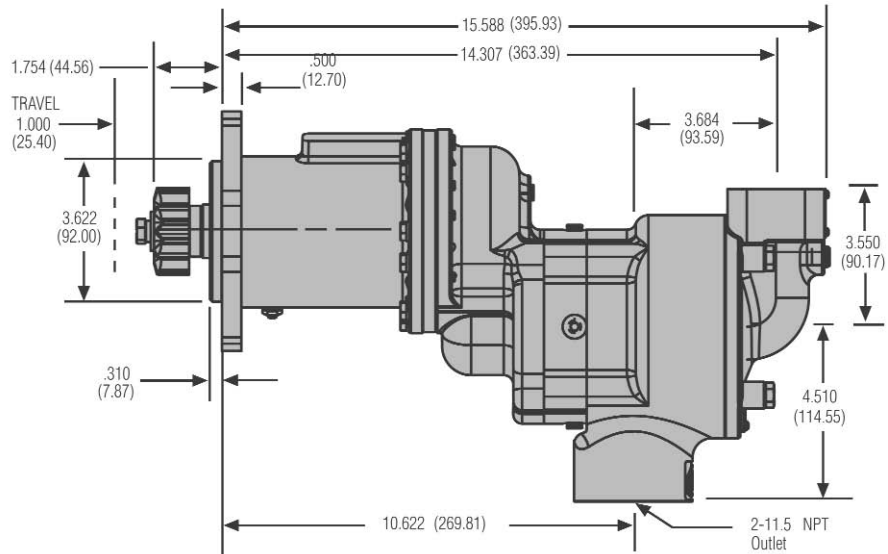
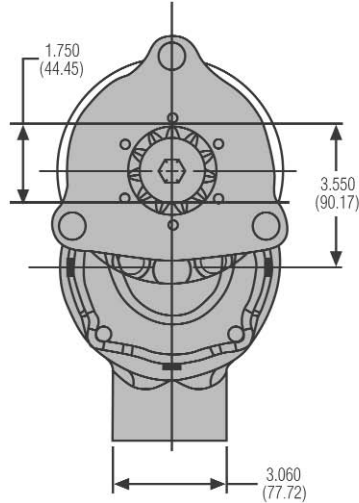

### ST544 Performance Information

Pressure PSI (bar)	Breakaway Torque ft-lb (Nm)	Speed @ Max HP RPM	Max Power HP (kW)	Flow @ Max HP SCFM (L/s)
60 (4.1)	74 (100)	1296	9 (7)	310 (146)
90 (6.2)	113 (153)	1480	16 (12)	430 (203)
120 (8.3)	147 (200)	1580	22 (17)	570 (269)
150 (10.3)	182 (247)	1620	28 (21)	710 (335)

### ST599 Performance Information

Pressure PSI (bar)	Breakaway Torque ft-lb (Nm)	Speed @ Max HP RPM	Max Power HP (kW)	Flow @ Max HP SCFM (L/s)
30 (2.1)	72 (98)	1185	8 (6)	340 (160)
60 (4.1)	132 (179)	1500	19 (14)	580 (274)
90 (6.2)	206 (280)	1530	30 (23)	780 (368)
120 (8.3)	247 (336)	1540	36 (46)	1000 (475)
150 (10.3)	295 (400)	1560	44 (58)	1240 (585)

# ST500 Series

*Bold Model Numbers indicate that a remanufactured model is available with the same part number (add an "R" to the number).*

**Most Obsolete Units ▶**

## ST500 Series Crossover Model Numbers

ST500 Current Product	ST400 Crossovers	ST600* Crossovers	ST700* Crossovers	ST900* Crossovers	ST800* Crossovers
ST599F03R95		ST699BP03R95			
ST599F03R77	ST400IC03R77				
ST599F03R51			ST775GCDP03R51	ST999CP03R51	
ST599F03R31		ST650BP03R31	ST750GBDP03R31	ST950BP03R31	SS815GB03R31
ST599F03R25	ST499C03R25		ST799GCDP03R25	ST999CP03R25	
ST599F03R25			ST750GCDP03R25	ST950CP03R25	
ST599F03L95		ST699BP03L95			
ST599F03L51		ST699BP03L51	ST799GCDP03L52		
ST599F03L31	ST499C03L32	ST650BP03L31		ST950BP03L32	SS815GB03L32
ST599F01R895	ST499C01R895				
ST544F06R31	ST400C06R31				
ST544F03R893	ST400C03R893				
ST544F03R85	ST400C03R85				
ST544F03R77	ST400C03R77				
ST544F03R31	ST400C03R31				
ST544F03R31	ST455C03R31				
ST544F03R31	ST400IC03R31				
ST544F03R31	ST455IC03R31				
ST544F03R29	ST400C03R29				
ST544F03R29	ST400IC03R29				
ST544F03R25	ST400C03R25				
ST544F01R85	ST400C01R85				
ST544F01R85	ST400IC01R85				
ST544F01R77	ST400C01R77				
ST544F01R29	ST400C01R29				
ST544F01R071	ST400C01R071				
ST544F01L32	ST400C01L32				

### ST500 SERIES MODEL CODING

**ST544 F 03 R 25 0 2 F J**



\* Large frame starter crossovers are dependent on the available air pressure and the size of the engine being started. Please consult your local IR representative.

## ST599 Number of Starts per Tank

(Assuming 2-Second Crank Time @ 90 PSI)

<b>Max Tank Pressure (psi)</b>	300	6	7	9	10	12	13	15	16	20	<b>Max Tank Pressure (bar)</b>
	270	5	7	8	9	10	12	13	14	18	
	240	4	6	7	8	9	10	11	12	16	
	210	4	5	6	7	7	8	9	10	14	
	180	3	4	4	5	6	7	7	8	12	
	150	2	3	3	4	4	5	6	6	10	
	120	1	2	2	3	3	3	4	4	8	
	90	1	1	1	1	1	2	2	2	6	
		80	100	120	140	160	180	200	220		
	302	378	454	529	605	680	756	832			
										<b>Gallons</b>	
										<b>Liters</b>	
										<b>Tank Size</b>	

## ST500 Genuine Ingersoll-Rand Replacement Kits

### Tune Up Kit Part Number

ST500-TK1

ST500-SK1

### Description

ST500 Starter Tune Up Kit

ST500 Seal Kit

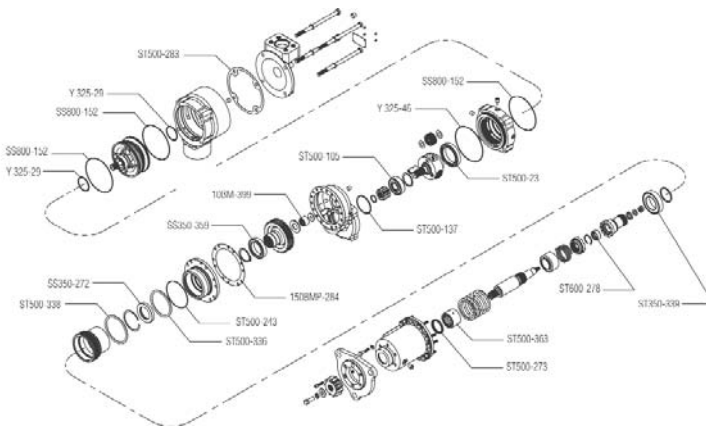



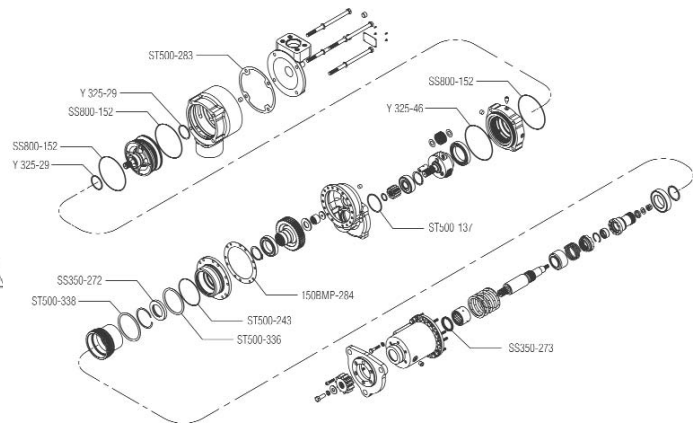

Exploded View of ST500-TK1 Part Location









Exploded View of ST500-SK1 Part Location

## ST500 Series Accessories

See catalog pages J-1 to J-18 for detailed Accessory information.

IR Part #	Description	Picture
<b>1</b> SMB-618	Push Button Valve	
<b>2</b> SMB-G618	Gas Rated Push Button Valve	
<b>3</b> 150BMP-1051B	1/4" 12 V Solenoid Valve	
<b>4</b> SRV125T	1-1/4" Relay Valve For Transit Aftermarket	
<b>5</b> SRV125	1-1/4" Relay Valve For Stationary Air	

IR Part #	Description	Picture
<b>6</b> 150BMP-1064L	1/8", 150 psi Pressure Gauge	
<b>7</b> ST500-A735	2" Road Splash Deflector	
<b>8</b> ST500-K166	SAE J518 Split Flange	
<b>9</b> 150BMP-1056	1/2" Check Valve	
<b>10</b> 150BMP-1067	1/2" Drain Valve	
<b>11</b> SMB-441	Liquid Sealant	

Red item numbers correspond to numbers in diagrams on page B-5.

# ST500 Series

## ST500 Diagram for a Typical Stationary Installation: Pre-engaged

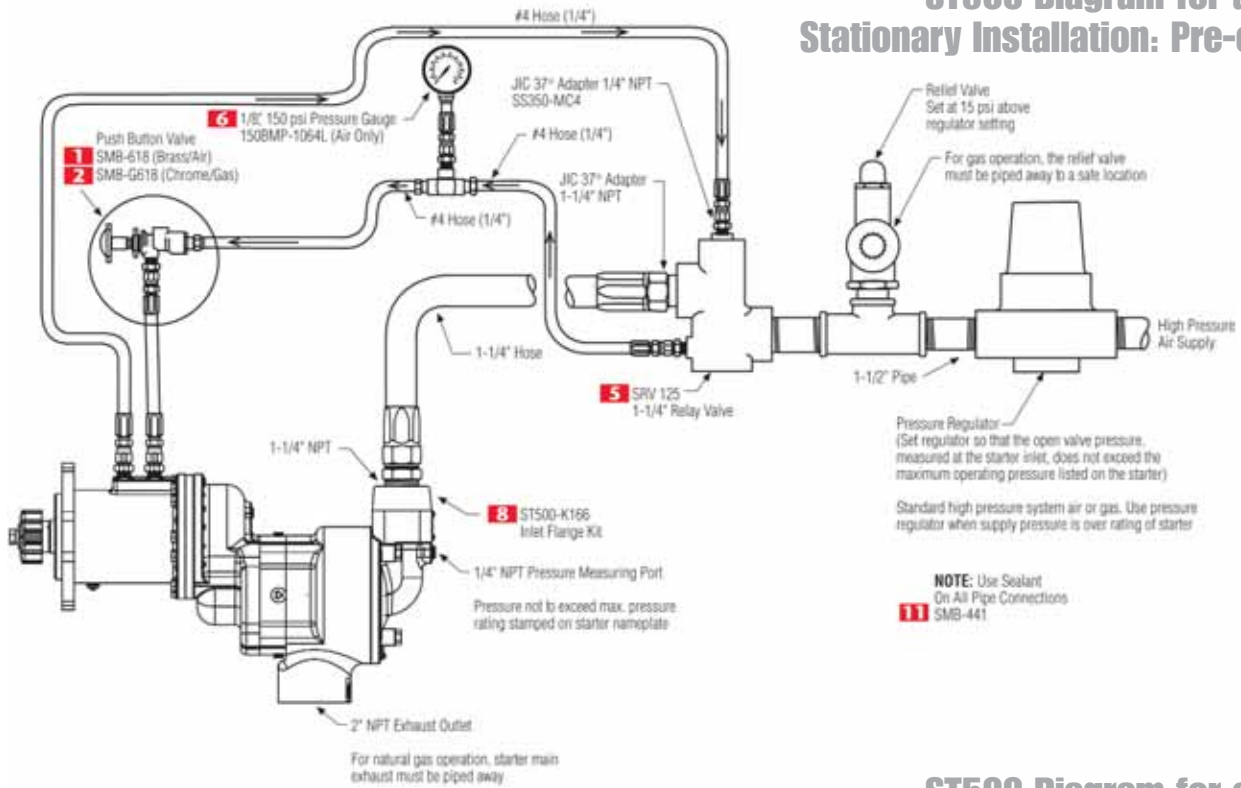

## ST500 Diagram for a Typical Vehicular Installation: Pre-engaged

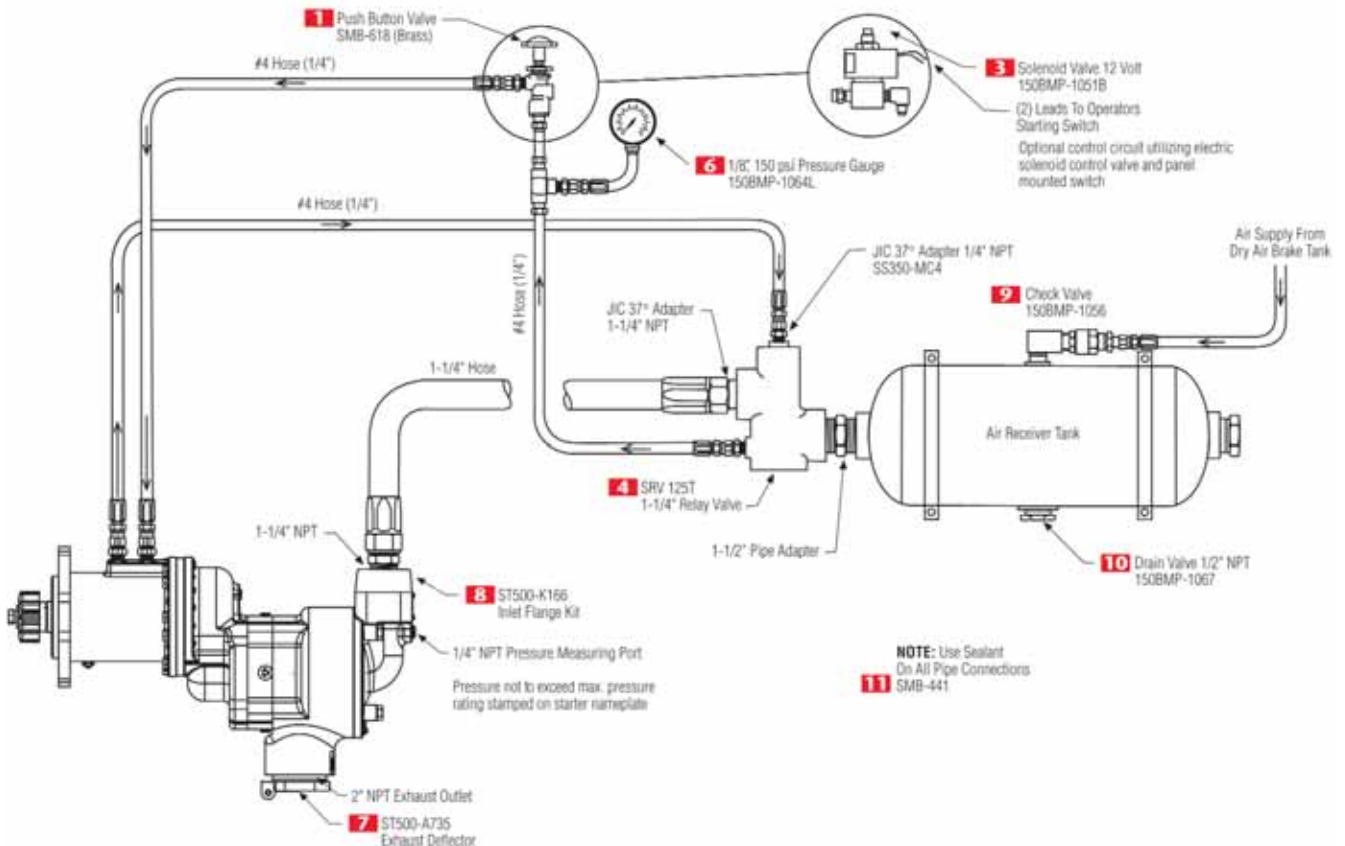



# ST500 Series Air Starters

*This chart is a condensed list of engines that can be cranked with an IR starter. For a complete list, please contact IR.*

## ST500 Series Engine Selection Guide

Manufacturer	Engine	CID	Liter	CYL	Type	Turbine Starter
<b>CATERPILLAR</b>	3126	439		6	Diesel	ST544F01R29
	3208	626	10.4	8	Diesel	ST544F03R29
	3306	638	10.5	6	Diesel	ST544F03R29
	3408	1099	18.0	8	Diesel	ST544F03R31
	3512	3158	51.8	12	Diesel	ST599F03R31
	3516	4210	69.0	16	Diesel	ST599F03R31
	C-10	620	10.3		Diesel	ST544F03R31
	C-12	732	12.0		Diesel	ST544F03R31
	G3306	638	10.5	6	Gas	ST544F03R31
	G3516	4210	69.0	16	Gas	ST599F03R31
<b>CUMMINS</b>	6C-8.3 SERIES	506	8.3	6	Diesel	ST544F03R29
	K19 SERIES	1150	18.8	6	Diesel	ST544F03R31
	K38 SERIES	2300	37.7	12	Diesel	ST599F03R31
	K50 SERIES	3067	50.3	16	Diesel	ST599F03R31
	QSK19	1150	19.0	6	Diesel	ST599F03R31
	QSK45	2746	45.0	12	Diesel	ST599F03R31
	QSK60	3660	60.0	16	Diesel	ST599F03R31
	QST30	1861	30.0	12	Diesel	ST599F03R31
<b>DETROIT DIESEL</b>	12V-149	1788	29.3	12	Diesel	ST544F03R31
	12V-71	851	13.9	12	Diesel	ST544F03R31
	12V-92	1104	18.1	12	Diesel	ST544F03R31
	16V-149	2384	39.1	16	Diesel	ST599F03R31
	16V-2000	1952	32.0	16	Diesel	ST599F03R31
<b>EMD GM</b>	8-645	5051	82.8	8	Diesel	ST599F03R31
	8-710	5160	84.6	8	Diesel	ST599F03R31
<b>MAN</b>	D 2565M	580	9.5	5	Diesel	ST544F03R77
	D2842	1338	21.9	12	Diesel	ST544F03R77
<b>MITSUBISHI</b>	S12A2(1)	2070	33.9	12V		ST544F24R893
	S12H	2265	37.1	12	Diesel	ST544F26R493
	S12R	2992	49.0	12V	Diesel	ST544F26R493
	S6A3	1133	18.6	6	Diesel	ST544F26R87
<b>WARTSILA</b>	8L20	4294	70.4	8		ST544C03R942
	2895G (SI/L)	2894	47.0	6L	Gas	ST599F03R31
	3512GL	3520	58.0	6L	Gas	ST599F03R31
	6AT25D	5392	88.4	6	Diesel	ST599F03R31
	6LAT25GL	5392	88.4	6	Diesel	ST599F03R31
	F1197G	1197	19.6	6	Gas	ST544F03R31
	F2895G (SI)	2894	47.4	6	Gas	ST599F03R31
	F3521G (SI)	3520	58.0	6L	Gas	ST599F03R31
	L36GL (D)	2193	36.0	12V	Gas	ST599F03R31
	L7042GL	7040	115.4	12V	Gas	ST599F03R31
<b>YANMAR</b>	6N18L	2608	42.8	6	Diesel	ST599C03R31
	8N21L	4904	80.4	8	Diesel	ST599C03R31





## Air Starters

# ST600 Series

**#1** Starter in the mining industry —  
for use with air only



**For engine displacement of:** Diesel—1000 to 5000 CID (16 to 80 liters)  
Carburated—2000 to 10,000 CID (32 to 160 liters)

### Features/Benefits

- Powerful 67 hp turbine motor uses no external lubrication
- Extended pilot for easier installation
- Offset pre-engaged ports for greater fitting positioning
- Quiet operation turbine motor requires no muffler
- Smooth pre-engagement for limited ring gear wear
- 39 lb (17.7 kg) weight makes it the lightest starter in its class

### Versatile

- Left- or right-hand rotation available
- 8 orientation options
- 30-150 (2.1-10.3 bars) psi operation



An **ST650BP03R31** starter is shown being mounted on a CAT3512 used on a mine haul truck.



An **ST650BP03R31** starter is shown mounted on a Detroit Diesel 12V-149R.



## ST600 Series DIMENSIONS

Weight lbs (kg)	
ST600	39 (17.7)

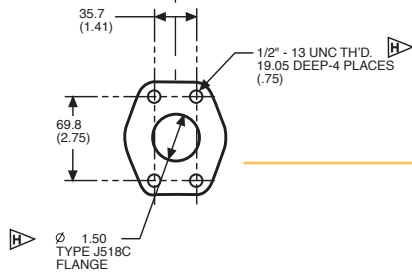
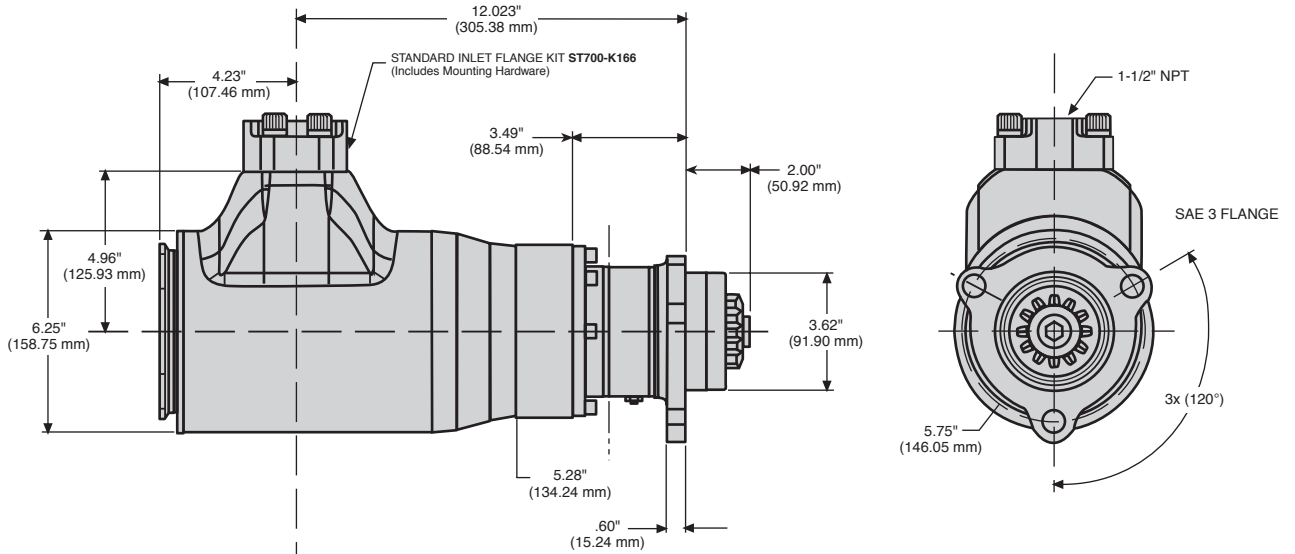

## Inlet Flange Kit (ST700-K166) DIMENSIONS

Weight lbs (kg)	
ST700-K166	4.5 (2.0)



# ST600 Series

## ST650B Performance Information

Pressure PSI (bar)	Breakaway Torque ft-lb (Nm)	Speed @ Max HP RPM	Max Power HP (kw)	Flow @ Max HP SCFM (L/s)
90 (6.2)	155 (210)	2300	34 (25)	850 (401)
120 (8.3)	225 (305)	2350	50 (37)	1150 (543)
150 (10.3)	260 (352)	2600	65 (49)	1450 (684)

## ST699B Performance Information

Pressure PSI (bar)	Breakaway Torque ft-lb (Nm)	Speed @ Max HP RPM	Max Power HP (kw)	Flow @ Max HP SCFM (L/s)
30 (2.1)	110 (149)	1950	20 (15)	600 (283)
60 (4.1)	195 (264)	2200	41 (31)	1150 (543)
90 (6.2)	290 (393)	2400	67 (50)	1700 (802)

**NOTE:** Overtorque safety clutch set between 330 to 440 ft-lb (447 to 596 Nm)

## ST650 Number of Starts per Tank

(Assuming 2-Second Crank Time @ 90 PSI)

<b>Max Tank Pressure (psi)</b>	300	6	7	9	10	12	13	15	16	20	<b>Max Tank Pressure (bar)</b>	
	270	5	7	8	9	10	12	13	14	18		
	240	4	6	7	8	9	10	11	12	16		
	210	4	5	6	7	7	8	9	10	14		
	180	3	4	4	5	6	7	7	8	12		
	150	2	3	3	4	4	5	6	6	10		
	120	1	2	2	3	3	3	4	4	8		
	90	1	1	1	1	1	2	2	2	6		
		80	100	120	140	160	180	200	220			
		302	378	454	529	605	680	756	832			
	<b>Tank Size</b>									<b>Gallons</b>	<b>Liters</b>	

## ST600 Genuine Ingersoll-Rand Replacement Kits

Tune Up Kit Part Number	Description
ST600-TK1	ST600 Starter Tune Up Kit
ST600-SK1	ST600 Starter Seal Kit

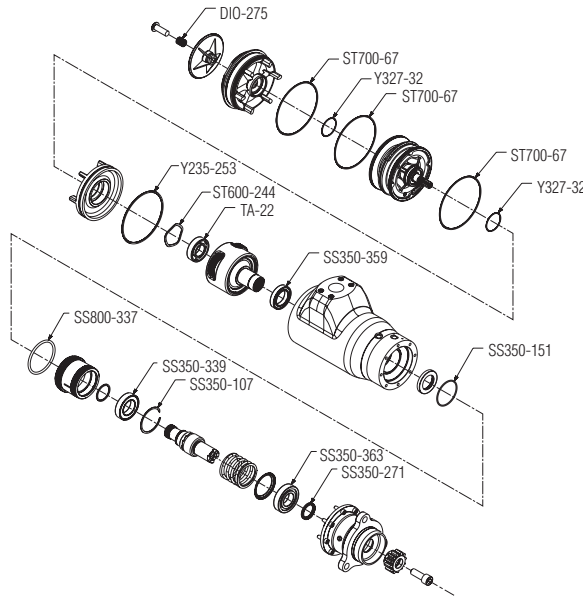

Exploded View of ST600-TK1 Part Location

## ST600 Series Accessories

See catalog pages J-1 to J-18 for detailed Accessory information.

IR Part #	Description	Picture	IR Part #	Description	Picture
<b>1</b> 150BMP-1051B	1/4" 12 V Solenoid Valve		<b>6</b> 150BMP-1064	1/8", 150 psi Pressure Gauge	
<b>2</b> 150BMP-2451B	1/4" 24 V Solenoid Valve		<b>7</b> ST900-267-24	1-1/2" Strainer (300 Mesh)	
<b>3</b> SMB-618	Push Button Valve		<b>8</b> ST900-266-24	1-1/2" Strainer Element (300 Mesh)	
<b>4</b> SRV150	1-1/2" Relay Valve		<b>9</b> 150BMP-1056	1/2" Check Valve	
<b>5</b> 150BMP-1058	Gladhand		<b>10</b> 150BMP-1067	1/2" Drain Valve	

Red item numbers correspond to numbers in diagrams on page C-5.

# ST600 Series

## ST600 Diagram for a Typical Stationary Installation: Pre-engaged

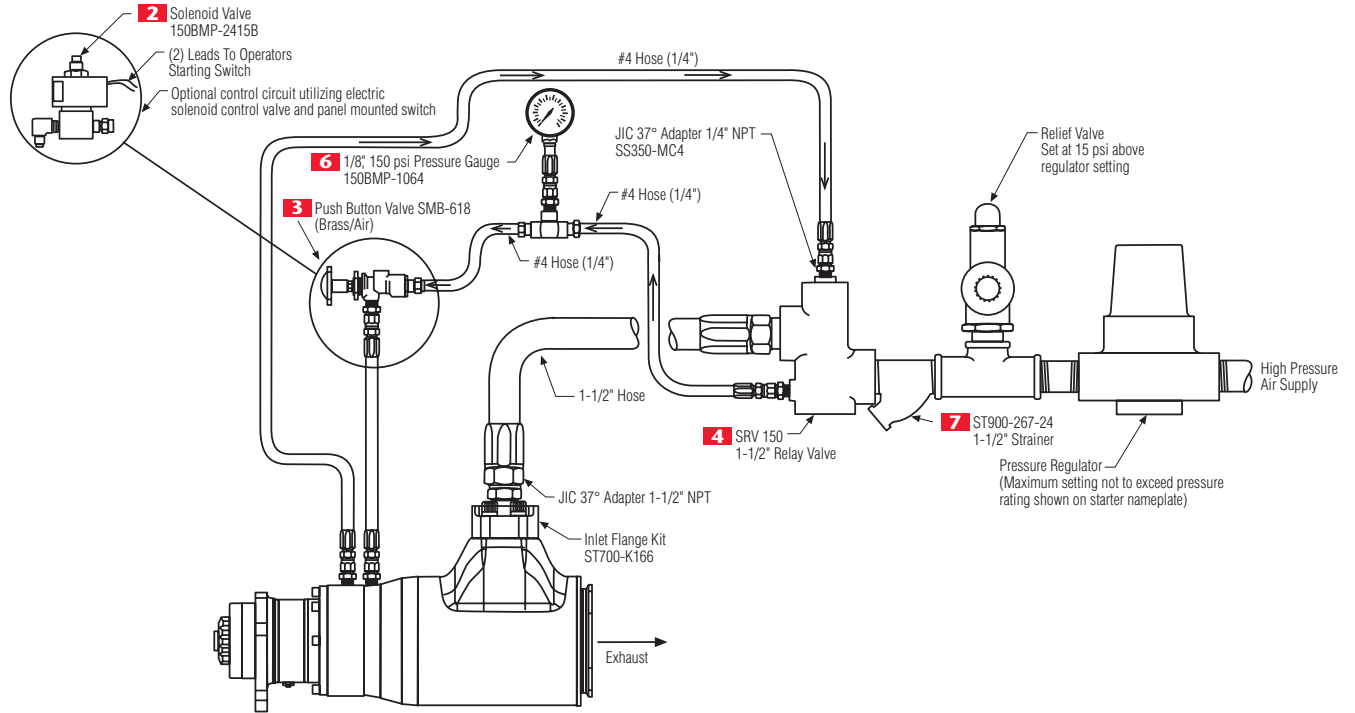

## ST600 Diagram for a Typical Vehicular Installation: Pre-engaged

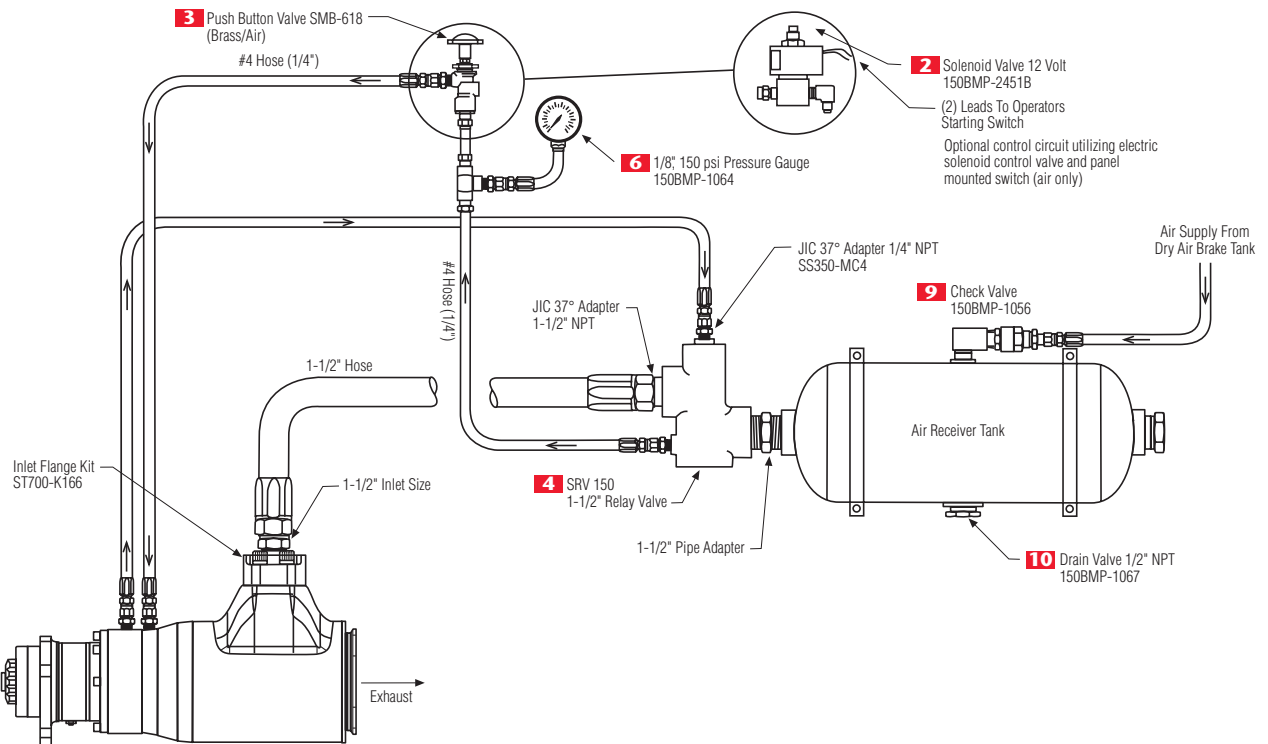



# ST600 Series Air Starters

*Bold Model Numbers indicate that a remanufactured model is available with the same part number (add an "R" to the number).*

**Most Obsolete Units ▶**

## ST600 Series Crossover Model Numbers

ST600 Available Units	ST900 Crossovers	ST700 Crossovers	SS800 Crossovers	Obsolete Units	Obsolete Units	Obsolete Units	Obsolete Units
ST650BP03R31	ST950BP03R31	ST750GBDP03R31	SS815GB03R31	SS800GB03R31	SS660RB991A01	SM450RB991A01	20BMB41RH-1
ST650BP03L31	ST950BP03L32	ST750GBDP03L32	SS815GB03L32	SS800GB03L32	SS660LB991A02	SM450LB991A02	20BMB47LH-4
ST650BP03R91		ST750GBDP03R91	SS815GB03R91	SS800GB03R91	SS660RB991A08		

*This chart is a condensed list of engines that can be cranked with an IR starter. For a complete list, please contact IR.*

## ST600 Series Engine Selection Guide

Manufacturer	Engine	CID	Liter	CYL	Type	Turbine Starter
<b>CATERPILLAR</b>	3508	2105	34.5	8	Diesel	ST650BP03R31
	3512	3158	51.8	12	Diesel	ST650BP03R31
	3516	4210	69	16	Diesel	ST650BP03R31
	D-353	1473	24.1	6	Diesel	ST650BP03R31
	D-364	1662	27.2	8	Diesel	ST650BP03R31
	D-399	3927	64.4	16	Diesel	ST650BP03R31
<b>CUMMINS</b>	K19 SERIES	1150	18.8	6	Diesel	ST650BP03R31
	K38 SERIES	2300	37.7	12	Diesel	ST650BP03R31
	QSK45	2746	45	12	Diesel	ST650BP03R31
	QSK60	3660	60	16	Diesel	ST650BP03R31
	QST30	1861	30	12	Diesel	ST650BP03R31
<b>DETROIT DIESEL</b>	12V-92	1104	18.1	12	Diesel	ST650BP03R31
	12V-149	1788	29.3	12	Diesel	ST650BP03R31
	16V-149	2384	39.1	16	Diesel	ST650BP03R31
	16V-71	1136	18.6	16	Diesel	ST650BP03R31
	16V4000		60	16	Diesel	ST650BP03R31
<b>WAUKESHA</b>	12VAT25D	10784	176.7	12	Diesel	2-ST650BP03R31
	6AT25D	5392	88.4	6	Diesel	ST650BP03R31
	F2896D	2894	47.4	6	Diesel	ST650BP03R31
	F3335D	3335	54.7	6	Diesel	ST650BP03R31
<b>WHITE ENGINES</b>	DNX-V8C	1348	22.1	8	Diesel	ST650BP03R31
	DNX-V8D	1468	24.1	8	Diesel	ST650BP03R31

## ST600 SERIES MODEL CODING

**ST6 50 B P 03 R 31**





## Air Starters

# ST700/ST900 Series



**For engine displacement of:** Diesel—1000 to 20,000 CID (16 to 320 liters)  
Carburated—2000 to 40,000 CID (32 to 660 liters)

### Features/Benefits

- Robust gearing handles extended crank cycles
- Sealed for use in gas and air applications
- Powerful 64 hp turbine motor uses no external lubrication
- Quiet turbine motor requires no external lubrication

### Versatile

- Left- or right-hand rotation available
- 4 inlet, 4 exhaust, and 16 housing orientations
- 30-150 psi (2.1-10.3 bars) operation
- Inertia and pre-engaged drives available



*The ST999BP03R31 starter is ready for use on a Cat 3608 engine.*



*The ST799GCDP03R31 starter is piped for use with gas on a Waukesha F3521GU used for power generation.*



## ST750/ST799GBI & ST950/ST999BI Inertia DIMENSIONS

Weight lbs (kg)	
ST750/ST799GBI	62 (28.1)
ST950/ST999BI	62 (28.1)

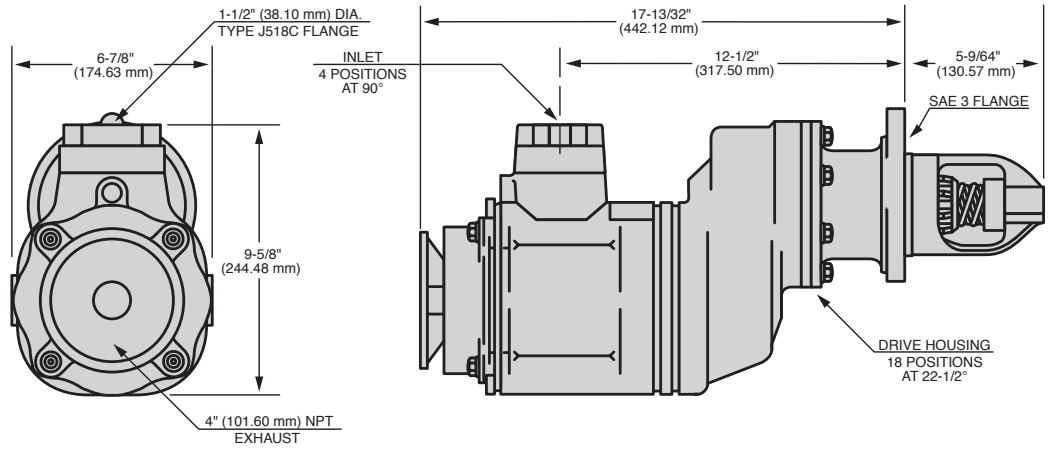

## ST750/ST799 & ST950/ST999 "B" & "C" Ratio Pre-engaged DIMENSIONS

Weight lbs (kg)	
ST750/ST799GBPD	63 (28.6)
ST950/ST999BP	63 (28.6)

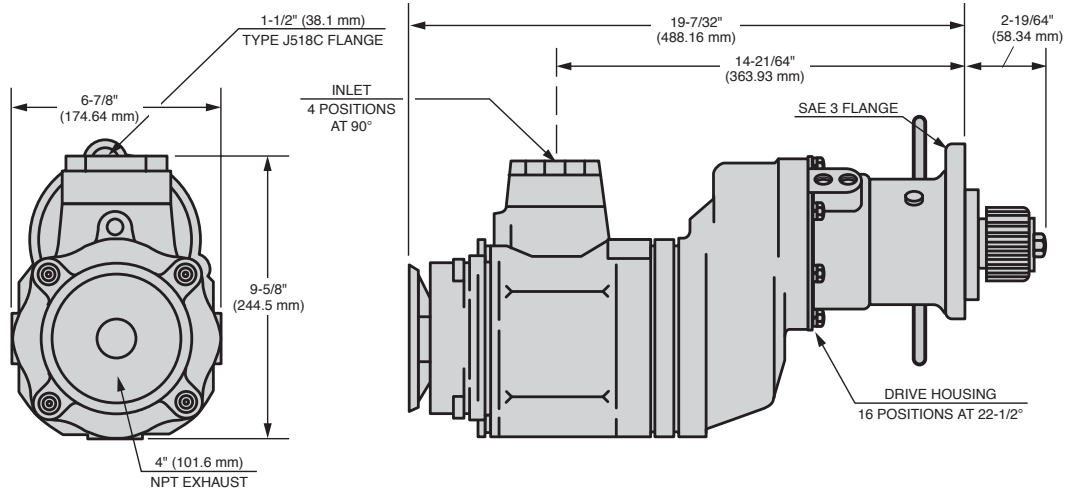

## ST750/ST799GDDP & ST950/ST999DP DIMENSIONS

Weight lbs (kg)	
ST750/ST799GDDP	92 (41.7)
ST950/ST999DP	92 (41.7)

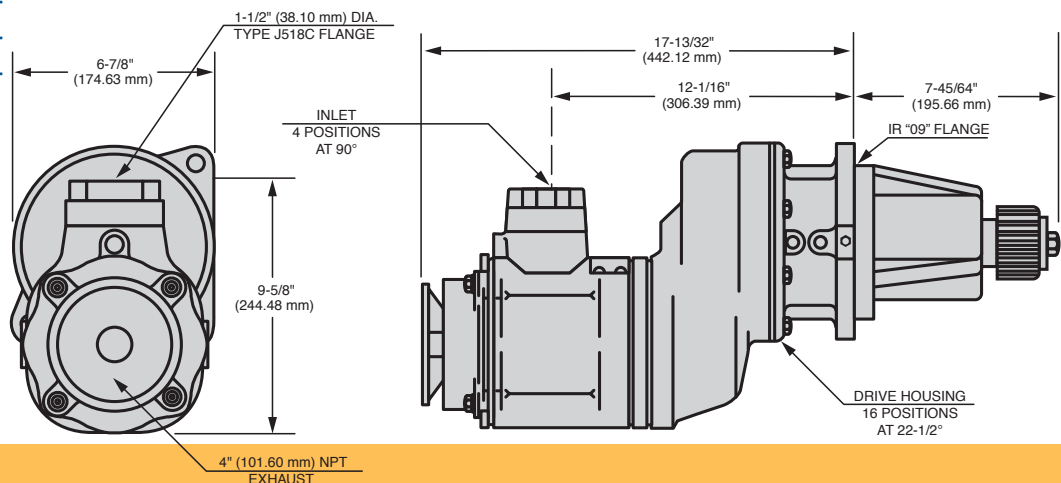



# ST700/ST900 Series

## ST750/ST950 B Ratio (Inertia & Pre-engaged) Performance Information

Pressure PSI (bar)	Breakaway Torque ft-lb (Nm)	Speed @ Max HP RPM	Max Power HP (kw)	Flow @ Max HP SCFM (L/s)
90 (6.2)	160 (217)	1950	30 (22)	850 (401)
120 (8.3)	225 (305)	2100	45 (34)	1100 (519)
150 (10.3)	250 (339)	2350	55 (41)	1300 (614)

## ST799/ST999 B Ratio (Inertia & Pre-engaged) Performance Information

Pressure PSI (bar)	Breakaway Torque ft-lb (Nm)	Speed @ Max HP RPM	Max Power HP (kw)	Flow @ Max HP SCFM (L/s)
30 (2.1)	110 (149)	1750	18 (13)	700 (330)
60 (4.1)	195 (264)	1950	36 (27)	1200 (566)
90 (6.2)	310 (420)	2250	66 (49)	1700 (802)

## ST750/ST950 C Ratio (Pre-engaged) Performance Information

Pressure PSI (bar)	Breakaway Torque ft-lb (Nm)	Speed @ Max HP RPM	Max Power HP (kw)	Flow @ Max HP SCFM (L/s)
90 (6.2)	190 (257)	1675	30 (22)	850 (401)
120 (8.3)	260 (352)	1800	45 (34)	1100 (519)
150 (10.3)	285 (386)	2000	55 (41)	1300 (614)

## ST799/ST999 C Ratio (Pre-engaged) Performance Information

Pressure PSI (bar)	Breakaway Torque ft-lb (Nm)	Speed @ Max HP RPM	Max Power HP (kw)	Flow @ Max HP SCFM (L/s)
30 (2.1)	130 (175)	1500	18 (13)	700 (330)
60 (4.1)	225 (305)	1630	36 (27)	1200 (566)
90 (6.2)	360 (485)	1935	66 (49)	1700 (802)

## ST750/ST950 D Ratio (Pre-engaged) Performance Information

Pressure PSI (bar)	Breakaway Torque ft-lb (Nm)	Speed @ Max HP RPM	Max Power HP (kw)	Flow @ Max HP SCFM (L/s)
90 (6.2)	255 (346)	1250	30 (22)	850 (401)
120 (8.3)	355 (481)	1350	45 (34)	1100 (519)
150 (10.3)	390 (528)	1500	55 (41)	1300 (614)

## ST799/ST999 D Ratio (Pre-engaged) Performance Information

Pressure PSI (bar)	Breakaway Torque ft-lb (Nm)	Speed @ Max HP RPM	Max Power HP (kw)	Flow @ Max HP SCFM (L/s)
30 (2.1)	175 (237)	1100	18 (13)	700 (330)
60 (4.1)	305 (413)	1250	36 (27)	1200 (566)
90 (6.2)	485 (657)	1450	66 (49)	1700 (802)

# Air Starters

## ST700/ST900 Series Accessories

See catalog pages J-1 to J-18 for detailed Accessory information.

IR Part #	Description	Picture
<b>1</b> 150BMP-1051B	1/4" 12 V Solenoid Valve	
<b>2</b> 150BMP-2451B	1/4" 24 V Solenoid Valve	
<b>3</b> SMB-618	Push Button Valve	
<b>4</b> SMB-G618	Gas Rated Push Button Valve	
<b>5</b> SRV150	1-1/2" Relay Valve For Air	
<b>6</b> SRV150SS	1-1/2" Gas Rated Relay Valve	
<b>7</b> 150BMP-1058	Gladhand	
<b>8</b> 150BMP-1064	1/8", 150 psi Pressure Gauge	

IR Part #	Description	Picture
<b>9</b> ST900-267-24	1-1/2" Strainer (300 Mesh)	
<b>10</b> ST900-267-32	2" Strainer (300 Mesh)	
<b>11</b> ST900-266-24	1-1/2" Strainer Element (300 Mesh)	
<b>12</b> ST900-266-32	2" Strainer Element (300 Mesh)	
<b>13</b> 150BMP-1056	1/2" Check Valve	
<b>14</b> 150BMP-1067	1/2" Drain Valve	

Red item numbers correspond to numbers in diagrams on page D-5.

## ST700/ST900 Number of Starts per Tank

(Assuming 1-Second Crank Time @ 90 PSI)

	7	8	10	11	13	15	16	18	20	
	6	7	9	10	11	13	14	16	18	
<b>Max Tank Pressure (psi)</b>	5	6	7	9	10	11	12	14	16	<b>Max Tank Pressure (bar)</b>
	4	5	6	7	8	9	10	11	14	
	3	4	5	6	7	7	8	9	12	
	2	3	4	4	5	6	6	7	10	
	2	2	2	3	3	4	4	5	8	
	1	1	1	1	2	2	2	2	6	
	80	100	120	140	160	180	200	220		<b>Gallons</b>
	302	378	454	529	605	680	756	832		<b>Liters</b>
	<b>Tank Size</b>									

# ST700/ST900 Series

## ST700/ST900 Inertia Installation

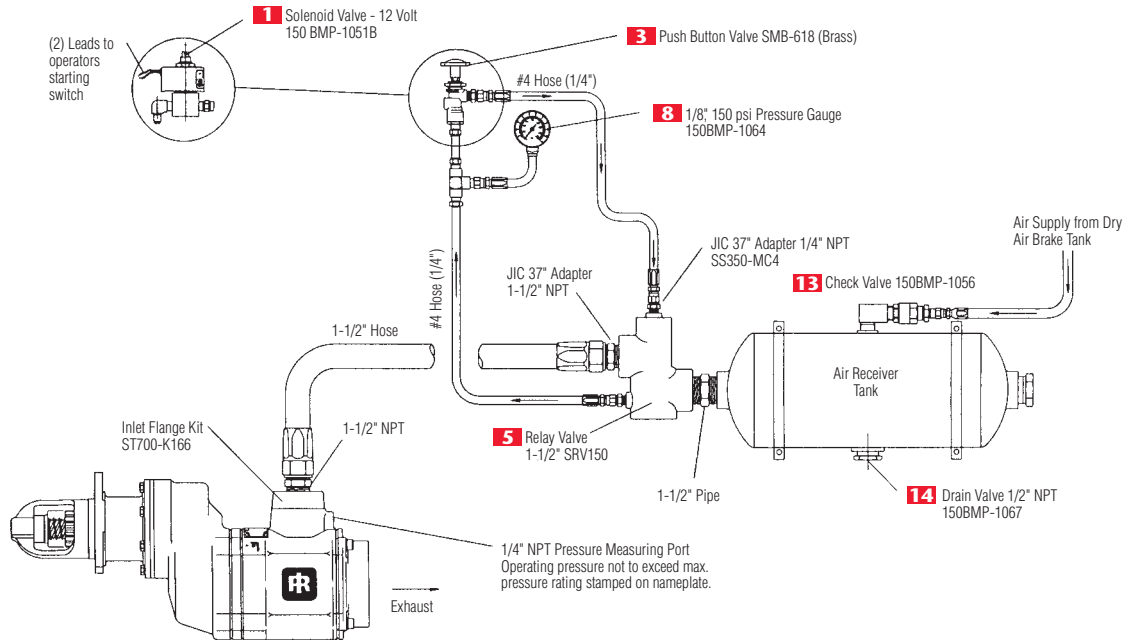

## ST700/ST900 Typical Stationary Installation

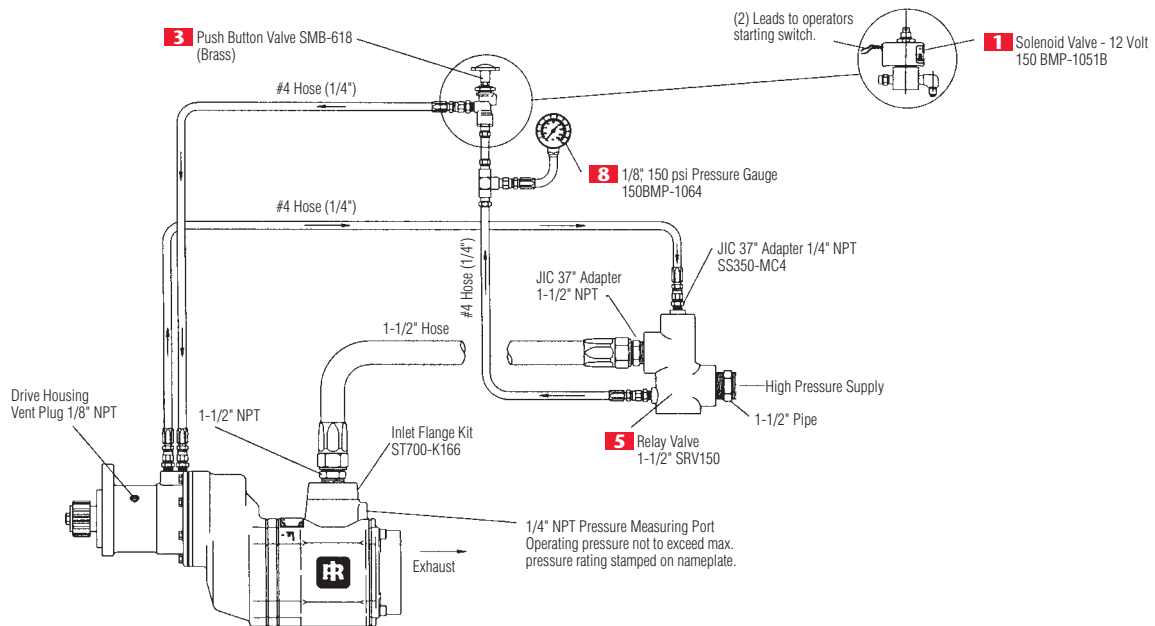

# Air Starters

## ST700/ST900 Typical Multiple Starter Application Installation

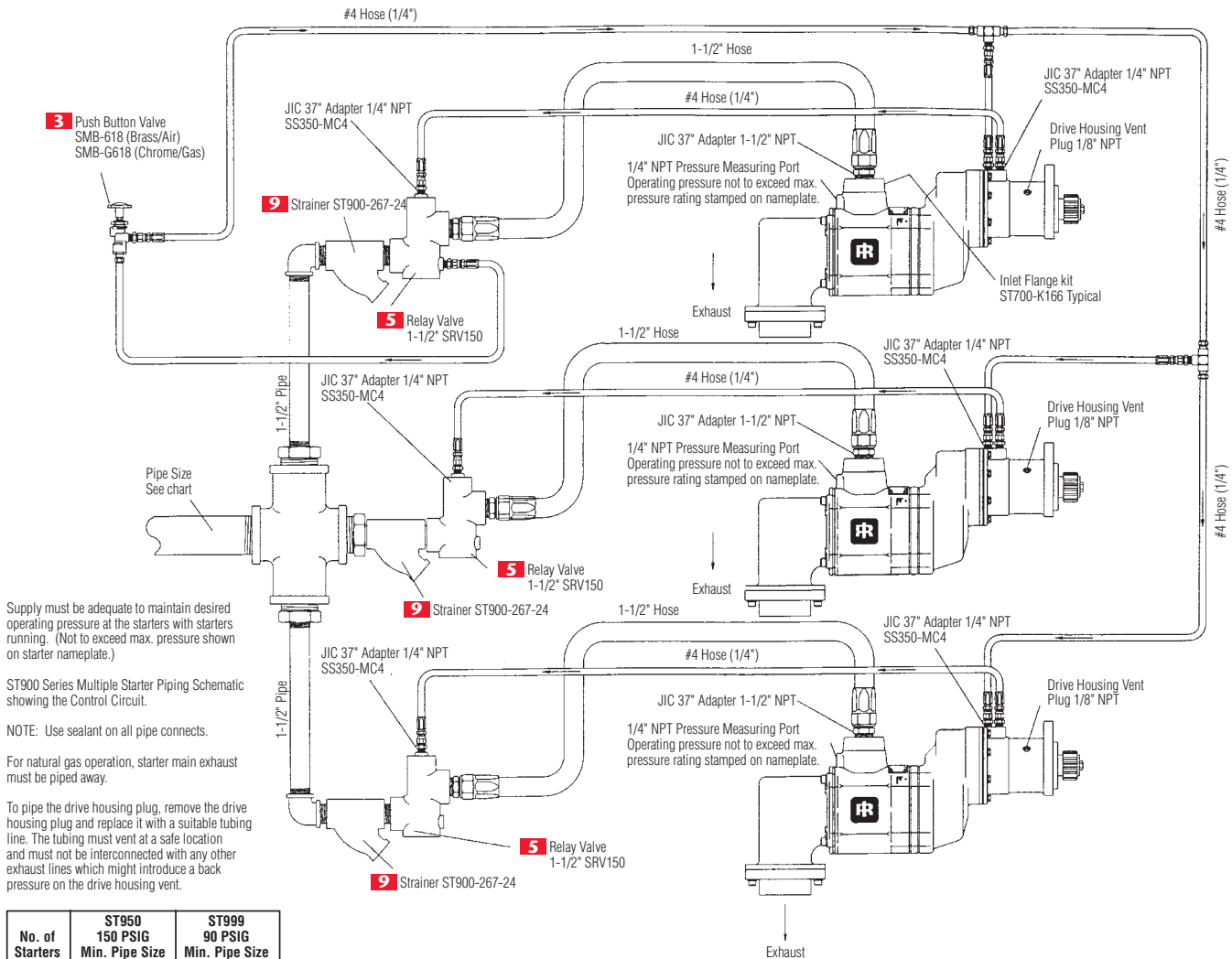

No. of Starters	ST950	ST999
	150 PSIG	90 PSIG
	Min. Pipe Size	Min. Pipe Size
2	2-1/2"	3"
3	3"	3-1/2"
4	3-1/2"	4"
5	3-1/2"	4"

# ST700/ST900 Series

*Bold Model Numbers indicate that a remanufactured model is available with the same part number (add an "R" to the number).*

## ST700/ST900 Series Crossover Model Numbers

**Most Obsolete Units ▶**

<b>ST900 Turbine Current Units</b>	<b>ST700 Turbine Current Units</b>	<b>SS800 Crossover Units</b>	<b>SS800 Obsolete</b>	<b>SS660 Obsolete</b>	<b>SM450 Obsolete</b>	<b>20BM Obsolete</b>
ST950BI03L32	ST750GBDI03L32	SS810GB03L32	SS800GB03L32	SS660LB991A02	SM450LB991A02	20BMB47LH-4
ST950BI03R31	ST750GBDI03R31	SS810GB03R31		SS660RB991A01	SM450RB991A01	20BMB41RH-1
ST950BP03L32	ST750GBDP03L32	SS815FGB03L32				
ST950BP03R31	ST750GBDP03R31	SS815FGB03R31				
ST950BP03L32	ST750GBDP03L32	SS815GB03L32	SS800GB03L32	SS660LB991A02	SM450LB991A02	20BMB47LH-4
ST950BP03L92	ST750GBDP03L92	SS815GB03L92-1738				
ST950BP03R31	ST750GBDP03R31	SS815GB03R31				
	ST750GBDP03R91	SS815GB03R91	SS800GB03R91	SS660RB991A08		
ST950BPJ3R493	ST750GCDPJ3R493	SS815GBDPJ3R493				
ST950CP03L26	ST750GCDP03L26	SS825FGC03L26				
ST950CP03R25	ST750GCDP03R25	SS825FGC03R25				
ST950CP03L26	ST750GCDP03L26	SS825GC03L26		SS660LB981A04	SM450LB981A04	20BM21LH-22
ST999CP03L52	ST750GCDP03L52	SS825GC03L52-21C				
ST950CP03R25	ST750GCDP03R25	SS825GC03R25		SS660RB981A03	SM450RB981A03	20BMB21RH-19
ST950BP03R31	ST750GCDP03R31	SS825GC03R31				
ST950DP09L52	ST750GDDP09L52	SS850GD09L52		SS660LD971A06	SM450LD971A06	20BMD52LH-26
ST950DP09R51	ST750GDDP09R51	SS850GD09R51		SS660RD971A05	SM450RD971A05	20BMD52RH-25

ST700 starters do not include an exhaust elbow.

All ST900 starters include an exhaust elbow. The letter "S" should be added to the part numbers to have the elbow removed.

# Air Starters

This chart is a condensed list of engines that can be cranked with an IR starter. For a complete list, please contact IR.

## ST700/ST900 Series Engine Selection Guide

Manufacturer	Engine	CID	Liter	CYL	Type	Turbine Starter
<b>CATERPILLAR</b>	3616	18016	295	16	Diesel	ST775GCDP03R25
	3618	20291	332.6	18	Diesel	ST775GCDP03R25
	G3516	4210	69	16	Nat. Gas	ST950BP03R31
	G3616	18036	295.6	16	Nat. Gas	ST950CP03R25S
	G-399	3927	64.4	16	Nat. Gas	ST950BP03R31
<b>CES-BESSEMER</b>	10W330	50894	834	14	Nat. Gas	4-ST950DP09L52
	12V-250			12	Nat. Gas	3-ST950DP09L52
	GMVA	21550	353	10	Nat. Gas	2 - ST950DP09L52
	GMVA	25860	423.8	12	Nat. Gas	2 - ST950DP09L52
	GMVW				Nat. Gas	3-ST950DP09L52
	GMWC	81388	1,333.70	16	Nat. Gas	5 - ST950DP
	GMXF	3134	51.4	4	Nat. Gas	ST950DP09L52
<b>DRESSER-RAND</b>	512KV	53080	869.8	12	Nat. Gas	ST950BP03R25
	PSVG-12	16590	271.9	12	Nat. Gas	ST950BP03R25
<b>EMD GM</b>	12-278	6809	111.6	12	Diesel	ST950DP09R51
	12-498	7576	124.1	12	Diesel	ST950DP09R51
<b>WARTSILA</b>	34SG	38560	632	16	Nat. Gas	ST775GCDP03R91
	34SG	43380	711	18	Nat. Gas	ST775GCDP03R91
<b>WAUKESHA</b>	12VAT25GL	10784	176.7	12	Nat. Gas	ST950CP03R25S (70-150 psi) ST999CP03R25S (30 - 90 psi)
	16VAT25GL	14378	235.6	16	Nat. Gas	ST950CP03R25S
	2895G (SI/L)	2894	47	6L	Nat. Gas	ST950BP03R25S
	7042G (SI/L)	7040	115	12V	Nat. Gas	ST950CP03R25S
	8LAT27GL	8699	143	8	Nat. Gas	ST950CP03R25S
	F2895	2894	47.4	6	Nat. Gas	ST950CP03R25S (70-150 psi) ST999CP03R25S (30 - 90 psi)
	F3521	3520	58	6L	Nat. Gas	ST950CP03R25S (70-150 psi) ST999CP03R25S (30 - 90 psi)
	H24GL (D)	1462	24	8L	Nat. Gas	ST950BP03R31
	L36GL (D)	2193	36	12V	Nat. Gas	ST950CP03R25S (70-150 psi) ST999CP03R31S (30 - 90 psi)
	L7040G	7040	115.4	6	Nat. Gas	ST950CP03R25S
	P9390G (L) (SI)	9388	153.8	16	Nat. Gas	ST950CP03R25

### ST700 SERIES MODEL CODING

ST7 50 G B D P 03 R 31 - 2 P

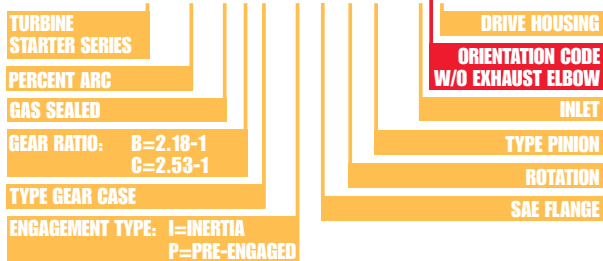

### ST900 SERIES MODEL CODING

ST9 50 B P 03 R 31 - 0 2 G

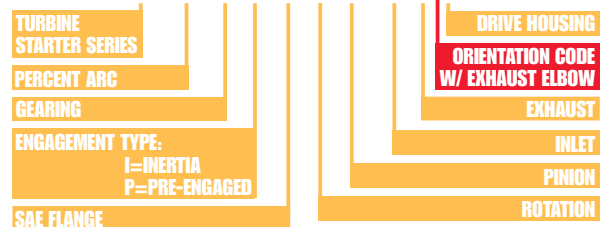

For non-standard positions order orientation "-POS"

# ST700/ST900 Series

## ST700/ST900 Series Genuine Ingersoll-Rand Replacement Kits

Tune Up Kit Part Number	Description
ST700-TK1	ST700 Tune Up Kit
ST700I-TK6	ST700 Inertia Front End Tune Up Kit
ST700P-TK7	ST700 Pre-Engaged Front End Tune Up Kit
ST700D-TK8	ST700 and ST900 D Ratio Kit (4 O-Rings, 1 Retainer Ring)
ST750R-TK2	ST700-TK1 and ST750R-A53 motor assembly for RH ST750 starters
ST750L-TK3	ST700-TK1 and ST750L-A53 motor assembly for LH ST750 starters
ST799R-TK4	ST700-TK1 and ST799R-A53 motor assembly for RH ST799 starters
ST799L-TK5	ST700-TK1 and ST799L-A53 motor assembly for LH ST799 starters
ST900-GK1	ST900 Gear Kit
ST900-SK1	ST900 Seal Kit

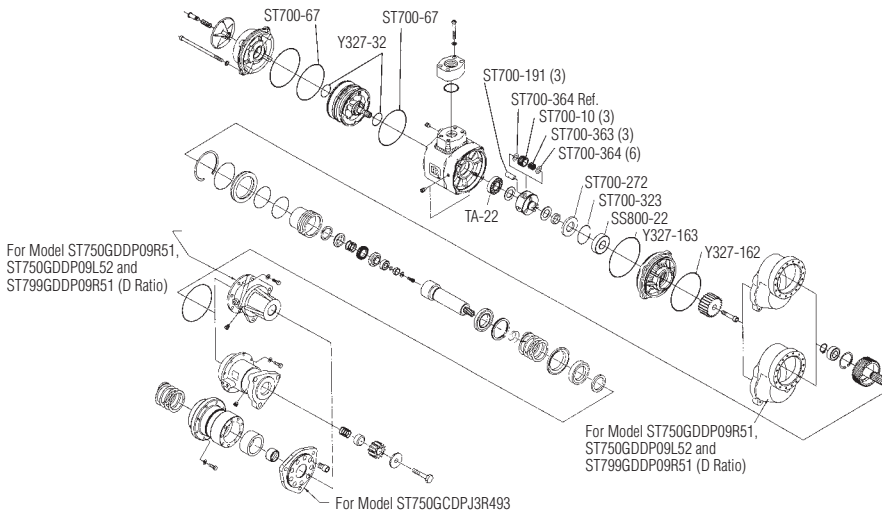

Exploded View of ST700-TK1 Part Location



ST700-TK1 Parts

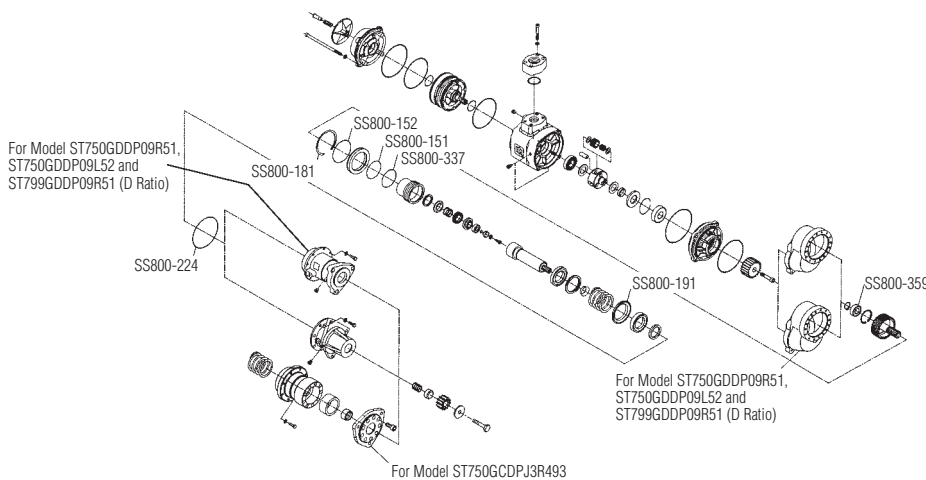

Exploded View of ST700P-TK7 Part Location



ST700P-TK7 Parts



# ST700/ST900 Series Air Starters

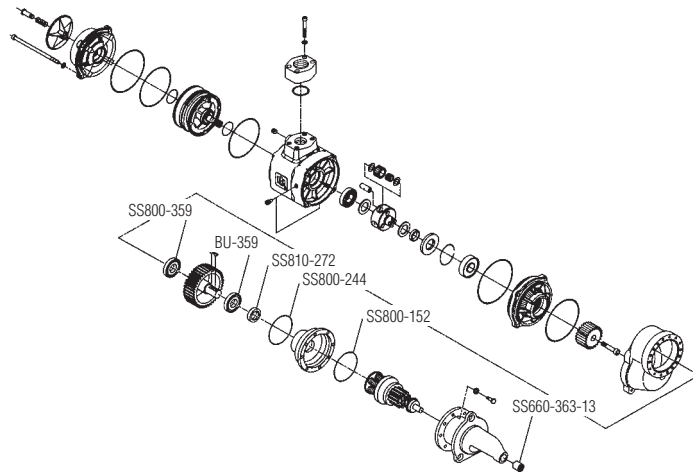

*Exploded View of ST700I-TK6 Part Location*

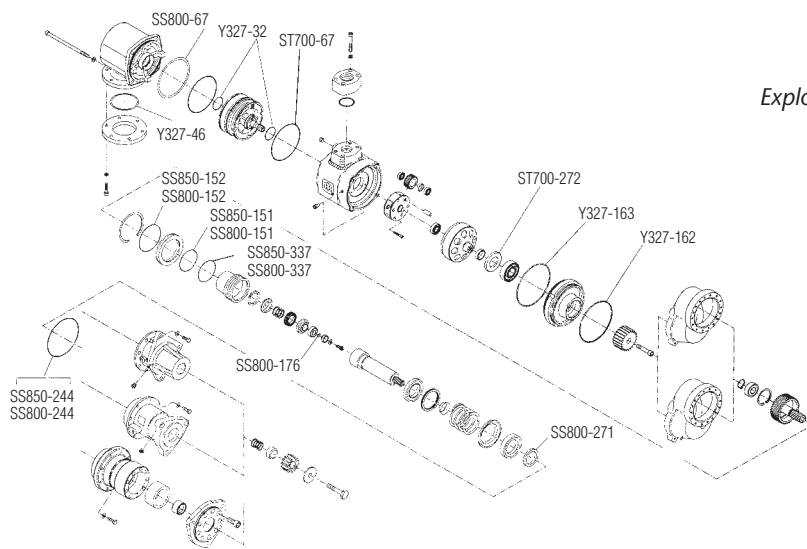

*Exploded View of ST900-SK1 Part Location*

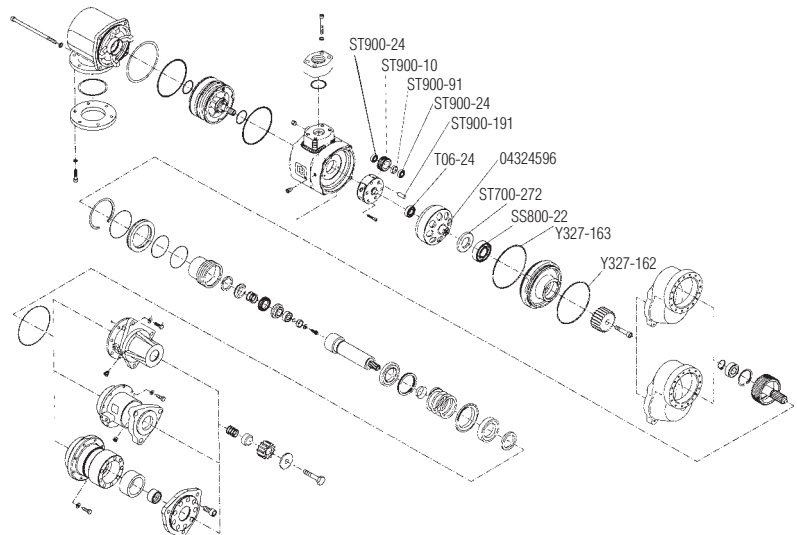

*Exploded View of ST900-GK1 Part Location*





## Air Starters

# 3BMG/5BMG Series



**For engine displacement of:** Diesel—up to 500 CID (8 liters)  
Carburated—up to 1000 CID (16 liters)

### Features/Benefits

- All models sealed for use in air or gas applications
- Inertia drive for fast, reliable starts
- Compact, inline design
- 9.5 hp motor on 5BMG;  
8.4 hp motor on 3BMG
- Back ports for injection lubricating

### Versatile

- 4 inlet, 4 exhaust, and 12 drive housing orientations
- Fits a wide range of small and medium size engines
- 90-150 psi (6.2-10.3 bars) operation



*Industry applications ideal for the 3BM/5BM Series starters: oil and gas production, shipping, trucking.*



## 3BMG Series DIMENSIONS

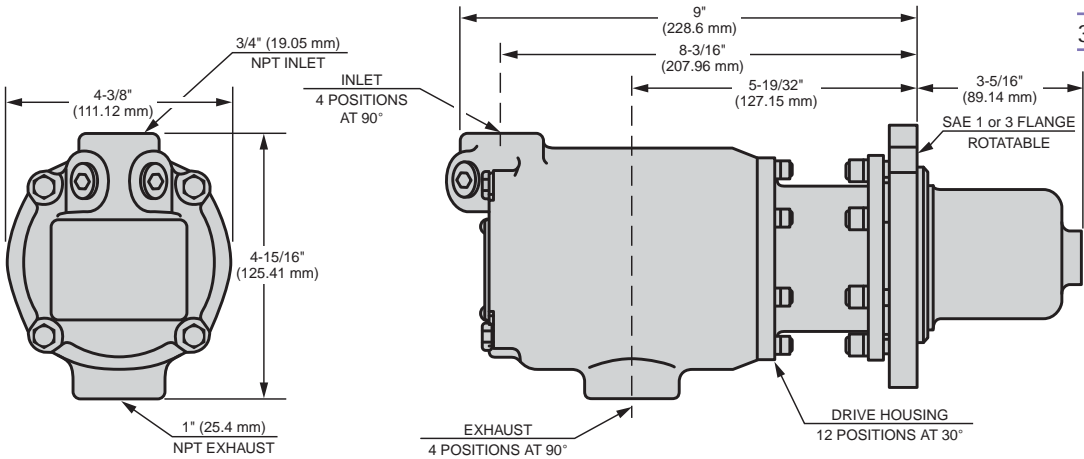

Weight lbs (kg)	
3BMG	18 (8.2)



## 5BMG Series DIMENSIONS

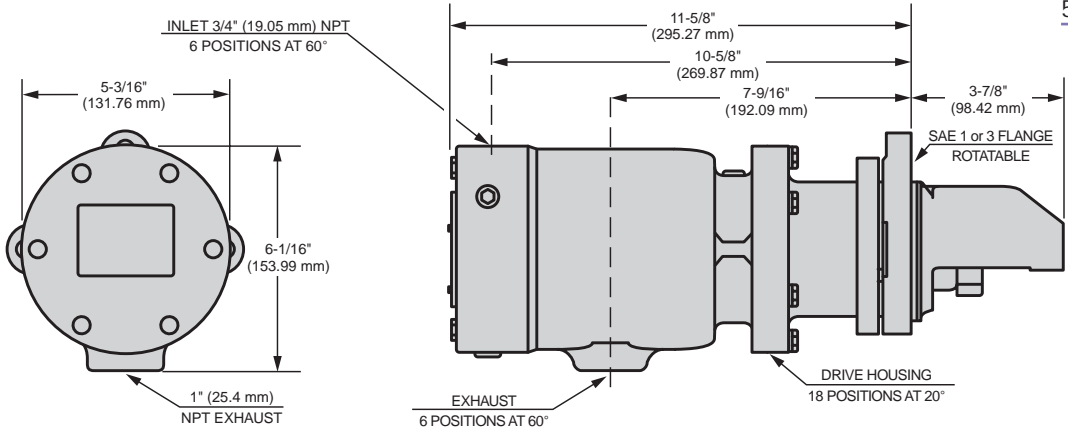

Weight lbs (kg)	
5BMG	35 (15.9)



## 3BMG/5BMG Series

### 3BMG Series Performance Information

Pressure PSI (bar)	Breakaway Torque ft-lb (Nm)	Speed @ Max HP RPM	Max Power HP (kw)	Flow @ Max HP SCFM (L/s)
90 (6.2)	23 (31)	2100	4.8 (4)	150 (71)
120 (8.3)	28 (38)	2500	6.7 (5)	220 (104)
150 (10.3)	36 (49)	3200	8.4 (6)	325 (153)

### 5BMG Series Performance Information

Pressure PSI (bar)	Breakaway Torque ft-lb (Nm)	Speed @ Max HP RPM	Max Power HP (kw)	Flow @ Max HP SCFM (L/s)
90 (6.2)	28 (38)	2100	5.0 (4)	165 (78)
120 (8.3)	35 (47)	2500	7.5 (6)	220 (104)
150 (10.3)	42 (57)	2700	9.5 (7)	310 (146)

### 3BMG Series Number of Starts per Tank

(Assuming 1-Second Crank Time @ 90 PSI)

300	35	52	70	87	105	122	140	157	20	<b>Max Tank Pressure (psi)</b>	<b>Max Tank Pressure (bar)</b>	
270	31	46	61	76	92	107	122	138	18			
240	26	39	52	65	79	92	105	118	16			
210	22	33	44	55	65	76	87	98	14			
180	17	26	35	44	52	61	70	79	12			
150	13	20	26	33	39	46	52	59	10			
120	9	13	17	22	26	31	35	39	8			
90	4	7	9	11	13	15	17	20	6			
	40	60	80	100	120	140	160	180				<b>Gallons Liters</b>
	151	227	302	378	454	529	605	680				
	<b>Tank Size</b>											



### 5BMG Series Number of Starts Per Tank

(Assuming 1-Second Crank Time @ 90 PSI)

300	32	48	63	79	95	111	127	143	20	<b>Max Tank Pressure (psi)</b>	<b>Max Tank Pressure (bar)</b>	
270	28	42	56	69	83	97	111	125	18			
240	24	36	48	60	71	83	95	107	16			
210	20	30	40	50	60	69	79	89	14			
180	16	24	32	40	48	56	63	71	12			
150	12	18	24	30	36	42	48	54	10			
120	8	12	16	20	24	28	32	36	8			
90	4	6	8	10	12	14	16	18	6			
	40	60	80	100	120	140	160	180				<b>Gallons Liters</b>
	151	227	302	378	454	529	605	680				
	<b>Tank Size</b>											

## 3BMG/5BMG Series Accessories

See catalog pages J-1 to J-18 for detailed Accessory information.

IR Part #	Description	Picture
1 3BM-WM07	3/4" Muffler	
2 3BM-A674	1" Muffler	
3 150BMP-1051B	1/4" 12 V Solenoid Valve	
4 150BMP-2451B	1/4" 24 V Solenoid Valve	
5 NL-24-8	In-Line Lubricator	
6 HDL2 (Stationary)	3/8" NPT Lubricator (1.3 cc)	
7 HDL3 (Transportation)	3/8" NPT Lubricator (0.4 cc)	
8 SMB-618	Push Button Valve	
9 SMB-G618	Push Button Valve For Natural Gas Operation	

IR Part #	Description	Picture
10 SRV125T	1-1/4" Relay Valve For Vehicular Applications	
11 SRV100	1" Relay Valve For Stationary Applications	
12 SRV150SS	1-1/2" Gas Rated Relay Valve	
13 150BMP-1058	Gladhand	
14 150BMP-1064	1/8", 150 psi Pressure Gauge	
15 ST900-267-16	1" Strainer (300 Mesh)	
16 ST900-266-16	1" Strainer Element (300 Mesh)	
17 150BM-A735	Road Splash Deflector	

Red item numbers correspond to numbers in diagrams on page E-5.

## 3BMG/5BMG (Gas) Stationary Installation

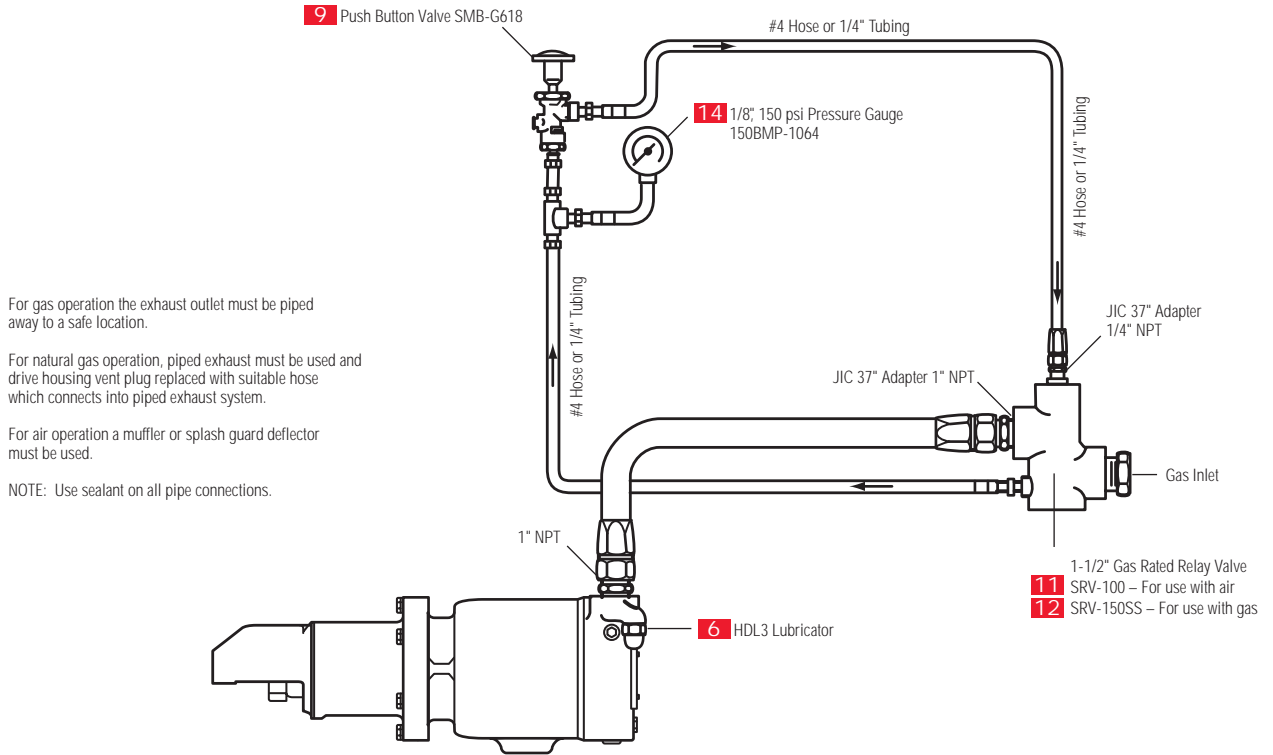

For gas operation the exhaust outlet must be piped away to a safe location.

For natural gas operation, piped exhaust must be used and drive housing vent plug replaced with suitable hose which connects into piped exhaust system.

For air operation a muffler or splash guard deflector must be used.

NOTE: Use sealant on all pipe connections.

## 3BMG Series Active Model Numbers

Starter Model	Flange Type	Drive Number	Pinion Specifications
3BMGA11RH-1F	SAE01	3BM-299-1	12T, 13B, 8/10P, 20PA, RH, 1.700"OD
3BMGA11RH-12F	SAE03	3BM-299-1	12T, 13B, 8/10P, 20PA, RH, 1.700"OD
3BMGA11RH-34F	SAE01	3BM-299-3	10T, 11B, 8/10P, 20PA, RH, 1.575"OD
3BMGA11RH-6F	SAE01	3BM-299-4	9T, 10B, 8/10P, 20PA, RH, 1.45"OD
3BMGA11RH-60F	SAE01	3BM-299-071	10T, 11B, 10/12P, 20PA, RH, 1.267"OD
3BMGA11RH-61F	Mitsubishi	3BM-299-85	11T, 12B, 3.5MOD, RH

## 5BMG Series Active Model Numbers

Starter Model	Flange Type	Drive Number	Pinion Specifications
5BMGA53RH-1F	SAE03	5BM-299-31	11T, 12B, 6/8P, 20PA, RH, 2.25"OD
5BMGA53RH-2F	SAE03	5BM-299-9	12T, 13B, 8/10P, 20PA, RH, 1.825"OD
5BMGA56RH-3F	SAE01	5BM-299-33	10T, 11B, 8/10P, 20PA, LH, 1.575"OD
5BMGA56RH-49F	SAE01	5BM-299-28	9T, 9.5B, 3MOD, 15PA, RH
5BMGA56RH-5F	SAE01	5BM-299-9	12T, 13B, 8/10P, 20PA, RH, 1.825"OD

### 3BMG/5BMG SERIES MODEL CODING

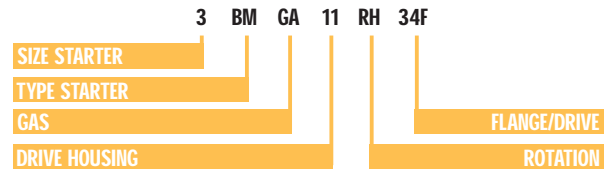

# 3BMG/5BMG Series

*This chart is a condensed list of engines that can be cranked with an IR starter. For a complete list, please contact IR.*

## 3BMG/5BMG Series Engine Selection Guide

Manufacturer	Engine	CID	Liter	CYL	Type	Vane Starter
CUMMINS	3B2.9	177	2.9	3	Diesel	3BMGA11RH-60F
	4B3.9	238	3.9	4	Diesel	3BMGA11RH60F
DETROIT DIESEL	2-53	106	1.7	2	Diesel	3BMGA11RH-12F
	6-53	318	5.2	6	Diesel	5BMGA56RH2
DORMAN	2LB	195	3.2	2	Diesel	3BMGA11RH-12F
	3LB	292	4.8	3	Diesel	3BMGA11RH-12F
INT HARVESTER	D282	282	4.6	6	Diesel	5BMGA56RH-3F
	RD372	372	6.1	6	Nat. Gas	3BMGA11RH-12F
	RD450	450	7.4	6	Nat. Gas	3BMGA11RH-12F
	UD236	236	3.9	6	Diesel	5BMGA56RH-3F
ISUZU	QD100					3BMGA11RH-61F
	QD145					3BMGA11RH-61F
WAUKESHA	140GZ	554	9.1	6	Nat. Gas	5BMGA53RH-2F
	140HK	525	8.6	6	Nat. Gas	5BMGA53RH-2F
	195GL	302	4.9	6	Nat. Gas	3BMGA11RH-34F
	6BL	245	4	6	Nat. Gas	3BMGA11RH-34F
	6SRK	517	8.5	6	Nat. Gas	5BMGA53RH-2F
	V1K	334	5.5	4	Nat. Gas	3BMGA11RH-12F
	V1L	316	5.2	4	Nat. Gas	3BMGA11RH-12F
	VRD283	283	4.6	6	Diesel	3BMGA11RH-1F
	VRD310	310	5.1	6	Diesel	3BMGA11RH-1F
	VRD330	426	7	6	Diesel	3BMGA11RH-1F
	VRG283	283	4.6	6	Nat. Gas	3BMGA11RH-34F
VRG310	310	5.1	6	Nat. Gas	3BMGA11RH-34F	
WHITE ENGINES	IX4E	188	3.1	4	Diesel	3BMGA11RH-1F
	RXC	529	8.7	6	Nat. Gas	5BMGA53RH-2F
	RXLD	558	9.1	6	Nat. Gas	5BMGA53RH-2F
	RXLX	529	8.7	6	Nat. Gas	5BMGA53RH-2F
	TDXC	501	8.2	6	Nat. Gas	5BMGA53RH-2F



# 3BMG/5BMG Series Air Starters

## 3BMG/5BMG Series Genuine Ingersoll-Rand Replacement Kits

Tune Up Kit  
Part Number

Description

3BM-TK2

3BM Tune Up Kit

5BM-TK2

5BM Tune Up Kit

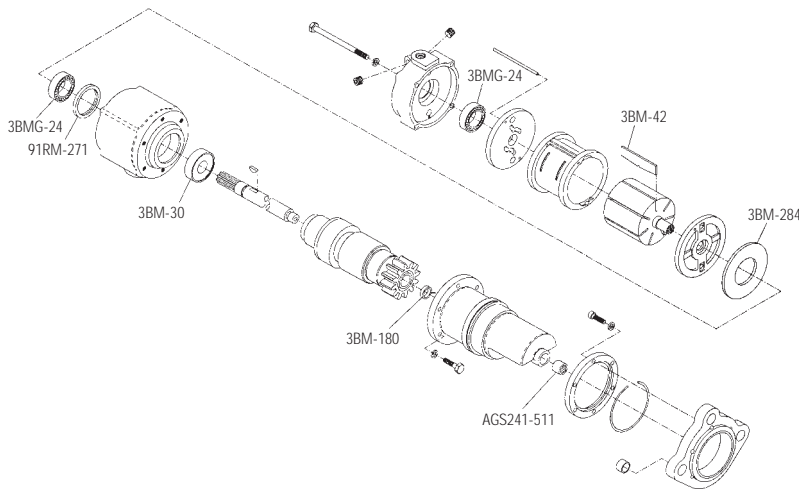

Exploded View of 3BM-TK2 Part Location



3BMG-TK2 Parts

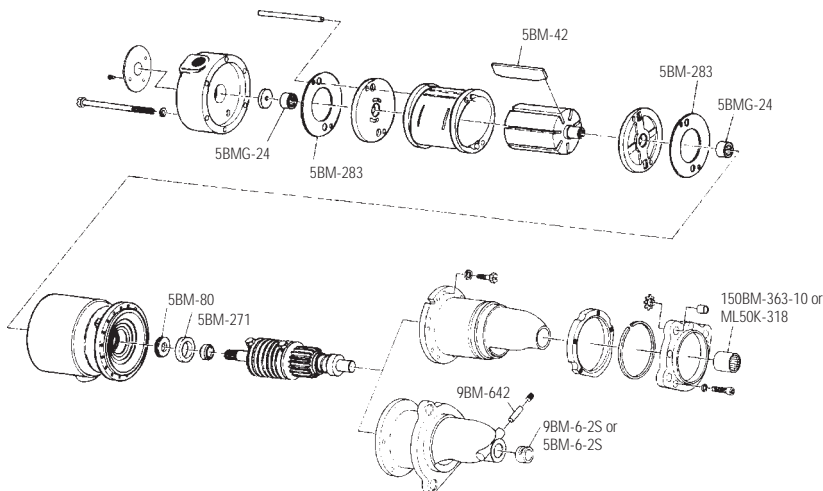

Exploded View of 5BM-TK2 Part Location



5BMG-TK2 Parts





## Air Starters

# SS175/SS350 Series



**For engine displacement of:** Diesel—200 to 1200 CID (3 to 20 liters)  
Carburated—400 to 2400 CID (6 to 40 liters)

### Features/Benefits

- Sealed for use in air or gas applications
- Rugged 36 hp motor on SS350;  
18 hp motor on SS175
- Overhung pre-engaged pinion design  
for fit-up flexibility
- Backcap ports for injection lubricating

### Versatile

- Left- and right-hand rotation available
- 4 inlet, 4 exhaust, and 12 housing  
orientations
- 90-150 psi (6.2-10.3 bars) operation
- Compact, lightweight design makes  
installation easier
- SAE01 and SAE03 flanges fit most  
worldwide manufacturers' engines



*The SS350GE03R29 starter is mounted on a Cummins M14TA to be used as a marine generator set.*



# Air Starters

## SS175G DIMENSIONS

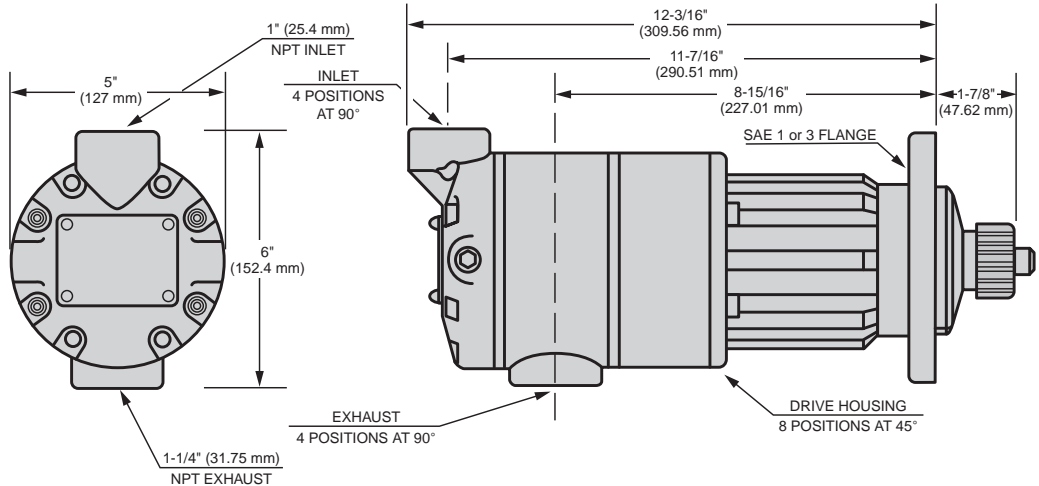

	Weight lbs (kg)
SS175G	29 (13.2)



## SS350G DIMENSIONS

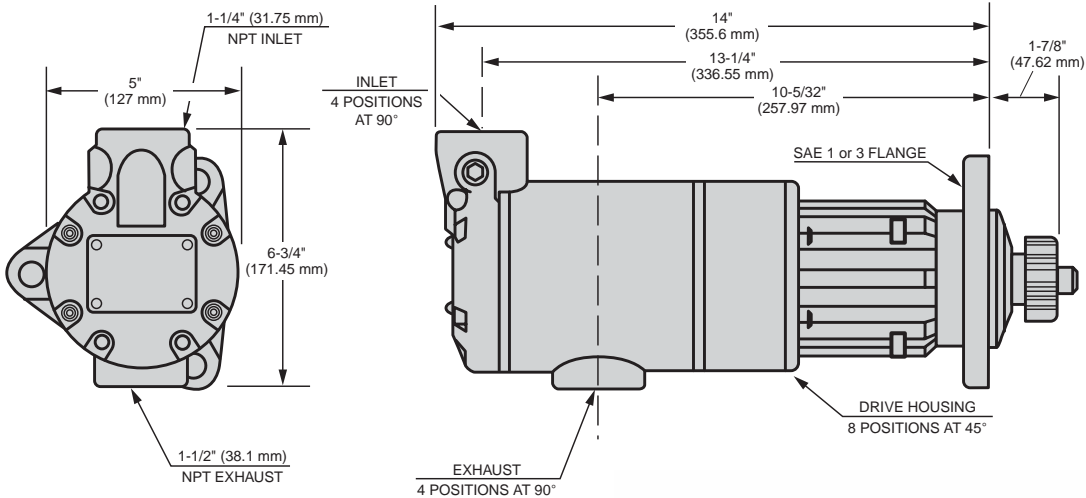

	Weight lbs (kg)
SS350G	33 (15.0)



# SS175/SS350 Series

## SS175 Performance Information

Pressure PSI (bar)	Breakaway Torque ft-lb (Nm)		Speed @ Max HP RPM		Max Power HP (kw)	Flow @ Max HP SCFM (L/s)
	B Ratio	E Ratio	B Ratio	E Ratio		
90 (6.2)	30 (41)	42 (57)	3500	2500	10 (7)	300 (142)
120 (8.3)	38 (51)	54 (73)	3800	2700	14 (10)	400 (189)
150 (10.3)	46 (62)	70 (95)	4100	2800	18 (13)	500 (236)

## SS350 Performance Information

Pressure PSI (bar)	Breakaway Torque ft-lb (Nm)		Speed @ Max HP RPM		Max Power HP (kw)	Flow @ Max HP SCFM (L/s)
	B Ratio	E Ratio	B Ratio	E Ratio		
90 (6.2)	70 (95)	100 (136)	2900	2000	19 (14)	525 (248)
120 (8.3)	90 (122)	130 (176)	3100	2200	27 (20)	750 (354)
150 (10.3)	110 (149)	160 (217)	3400	2400	36 (27)	900 (425)

## SS175 Number of Starts per Tank

(Assuming 1-Second Crank Time @ 90 PSI)

Max Tank Pressure (psi)	300	17	26	35	44	52	61	70	79	20	Max Tank Pressure (bar)
	270	15	23	31	38	46	53	61	69	18	
	240	13	20	26	33	39	46	52	59	16	
	210	11	16	22	27	33	38	44	49	14	
	180	9	13	17	22	26	31	35	39	12	
	150	7	10	13	16	20	23	26	29	10	
	120	4	7	9	11	13	15	17	20	8	
	90	2	3	4	5	7	8	9	10	6	
		40	60	80	100	120	140	160	180		
		151	227	302	378	454	529	605	680		
	Tank Size									Gallons Liters	

## SS350 Number of Starts per Tank

(Assuming 1-Second Crank Time @ 90 PSI)

Max Tank Pressure (psi)	300	10	15	20	25	30	35	40	45	20	Max Tank Pressure (bar)
	270	9	13	17	22	26	31	35	39	18	
	240	7	11	15	19	22	26	30	34	16	
	210	6	9	12	16	19	22	25	28	14	
	180	5	7	10	12	15	17	20	22	12	
	150	4	6	7	9	11	13	15	17	10	
	120	2	4	5	6	7	9	10	11	8	
	90	1	2	2	3	4	4	5	6	6	
		40	60	80	100	120	140	160	180		
		151	227	302	378	454	529	605	680		
	Tank Size									Gallons Liters	

## SS175/350 Series Accessories

See catalog pages J-1 to J-18 for detailed Accessory information.

IR Part #	Description	Picture
1 SS350-A674	1 1/2" Muffler	
2 150BM-A674	1-1/4" Muffler	
3 150BMP-1051B	1/4" 12 V Solenoid Valve	
4 150BMP-2451B	1/4" 24 V Solenoid Valve	
5 NL-24-8	In-Line Lubricator	
6 HDL2 (Stationary)	3/8" NPT Lubricator (1.3 cc)	
7 HDL3 (Transportation)	3/8" NPT Lubricator (0.4 cc)	
8 SMB-618	Push Button Valve	
9 SMB-G618	Push Button Valve For Natural Gas Operation	

IR Part #	Description	Picture
10 SRV125T	1-1/4" Relay Valve For Vehicular Applications	
11 SRV125	1-1/4" Relay Valve For Stationary Applications	
12 SRV150SS	1-1/2" Gas Rated Relay Valve	
13 150BMP-1058	Gladhand	
14 150BMP-1064	1/8", 150 psi Pressure Gauge	
15 ST900-267-24	1-1/2" Strainer (300 Mesh)	
16 ST900-266-24	1-1/2" Strainer Element (300 Mesh)	
17 150BM-A735	1-1/4" Road Splash Deflector	
18 SS350-A735	1-1/2" Road Splash Deflector	
19 150BMP-1056	1/2" Check Valve	

Red item numbers correspond to numbers in diagrams on page F-5.

# SS175/SS350 Series

## SS175/SS350 Stationary Installation

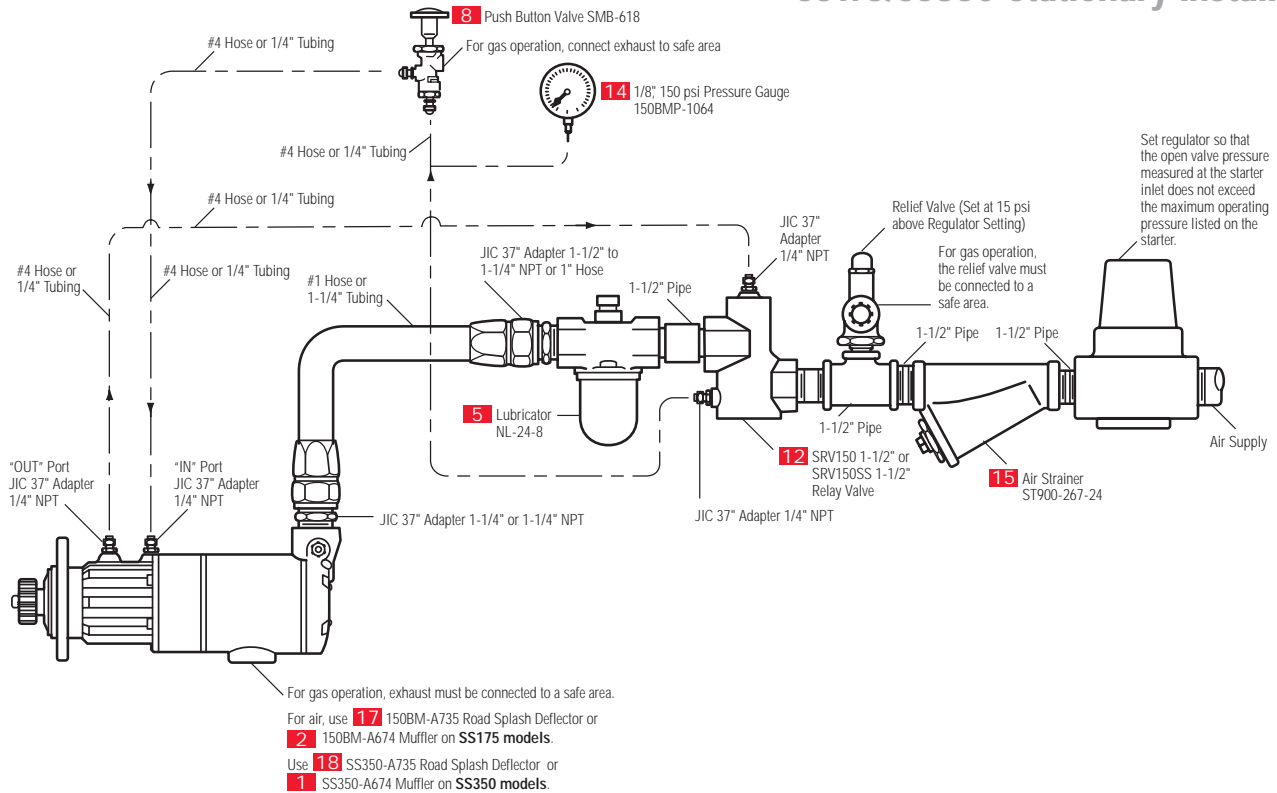

## SS175/SS350 Typical Vehicular Installation

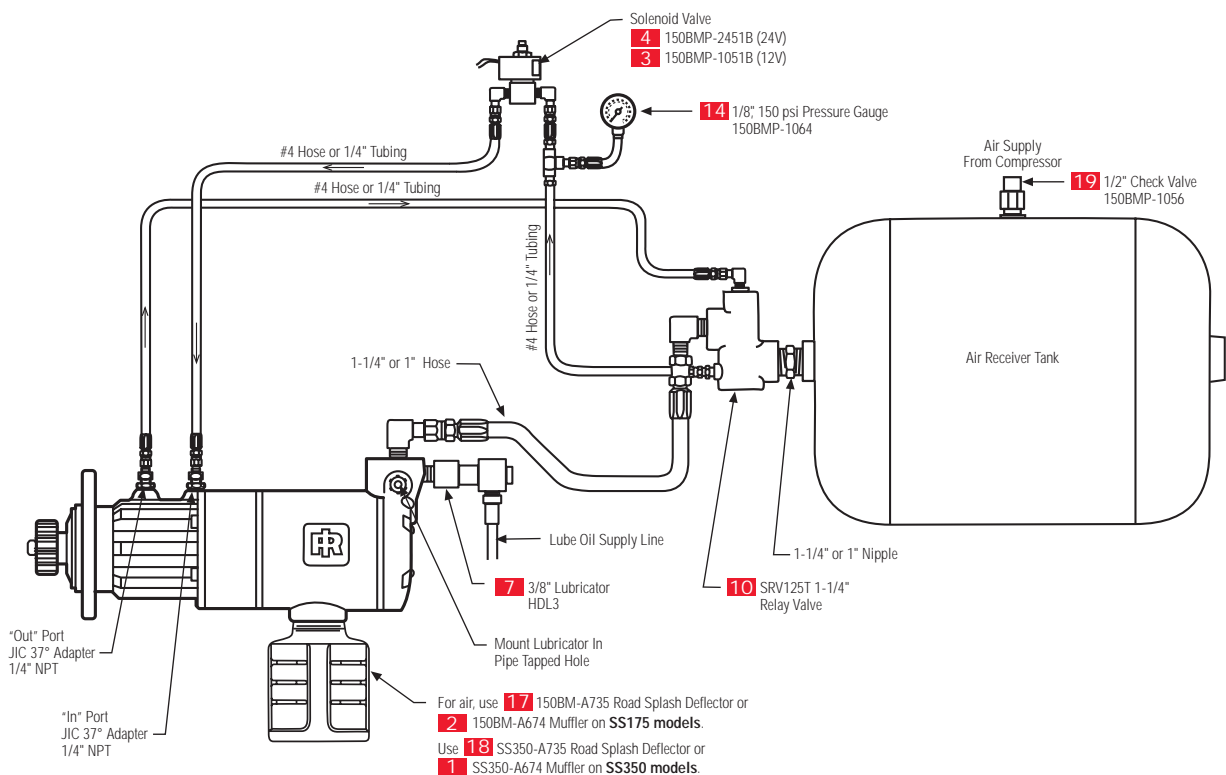

## SS175 Crossover Model Numbers

SS175 Available Units	Obsolete Units
SS175GB01L-00A	
SS175GB01L-02J	
SS175GB01R071-02J	
SS175GB01R15-02J	5BMGA12RH-3F
SS175GB01R77-02J	5BMGA56RH-49F
SS175GB01R81-02J	
SS175GB01R85-02J	
SS175GB03L-01E	
SS175GB03R15-02H	
SS175GB03R31-02H	
SS175GB03R77-02H	
SS175GE01L30-02J	
SS175GE01R15-02J	
SS175GE01R21-02J	
SS175GE01R29-02J	5BMGA12RH-5F
SS175GE01R77-02J	
SS175GE01R85-02J	5BMGA56RH-52F
SS175GE01R99-00D	
SS175GE01R99-03I	
SS175GE03L16-02H	
SS175GE03L30-02H	
SS175GE03L32-02H	
SS175GE03R29-02F	
SS175GE03R29-02H	5BMGA11RH-2
SS175GE03R29-03G	
SS175GE03R31-02H	
SS175GE03R37-02H	
SS175GE03R25-02H	5BMGA11RH-1

## SS350 Crossover Model Numbers

SS350 Available Units	Obsolete Units
SS350GB01L30-02J	
SS350GB01R29-02J	
SS350GB01R77SR-02J	
SS350GB01R85-02H	
SS350GB01R85-02J	150BMPAB01R85
SS350GB01R99-00D	
SS350GB03R29-02H	
SS350GB03R29SR-02H	
SS350GB03R29SR-03I	
SS350GB03R31-02H	
SS350GB03R77-02H	150BMPAB0377
SS350GB03R85-02H	150BMPAC03R77
SS350GE01R15-02H	
SS350GE01R29-00L	
SS350GB01R77-02J	150BMPAB01R77
SS350GE01R29-02J	
SS350GE01R31-02J	
SS350GE01R85-02J	
SS350GE03L30-02H	
SS350GE03L32-00H	
SS350GE03L32-01I	
SS350GE03L32-02G	
SS350GE03L32-02H	
SS350GE03R21-02H	
SS350GE03R25-03J-S	
SS350GE03R29-02F	
SS350GE03R29-02H	
SS350GE03R29-03I	
SS350GE03R29-03J	
SS350GE03R31-00A	
SS350GE03R31-00F	
SS350GE03R31-00G	
SS350GE03R31-00L	
SS350GE03R31-02G	
SS350GE03R31-02H	
SS350GE03R31-02L	
SS350GE03R31-03J	
SS350GE03R31-1552	
SS350GE03R31-1553	
SS350GE03R37-02H	
SS350GE03R77-02H	
SS350GE03R85-02H	150BMPAC03R85
SS350GE03R99-03I	
SS350GE01R85-02H	150BMPAC01R85

### SS175/SS350 MODEL CODING

SS175 G E 03 R 31 XX 024

SIZE STARTER	ORIENTATION
GAS SEALED	SR=SPARK RESISTANT
GEAR RATIO	PINION CODING
SAE No. MOUNTING FLANGE	ROTATION L or R

# SS175/SS350 Series

*This chart is a condensed list of engines that can be cranked with an IR starter. For a complete list, please contact IR.*

## SS175/SS350 Series Engine Selection Guide

Manufacturer	Engine	CID	Liter	CYL	Type	Vane Starter
CATERPILLAR	1673	638	10.5	6	Diesel	SS175GE03R29
	3126	439	7.2	6	Diesel	SS175GB01R29
	3145	525	8.6	6	Diesel	SS175GE03R29
	D-315	350	5.7	4	Diesel	SS175GB03R31
	D-320	252	4.1	4	Diesel	SS175GB03R31
	D-330TA	350	5.7	4	Diesel	SS175GB03R31
CUMMINS	6BT5.9	359	5.9	6	Diesel	SS175GE01R071
	6BTA180	359	5.9	6	Diesel	SS175GE01R071
	V6-140	352	5.8	6	Diesel	SS175GE03R29
	V6-155	378	6.2	6	Diesel	SS175GE03R29
	ISB	359	5.9	6	Diesel	SS175GE01R071
	ISC	506	8.3	6	Diesel	SS175GE01R29
	ISL	549	9.0	6	Diesel	SS350GE03R29
	ISM	659	10.8	6	Diesel	SS350GE03R31
	N14	855	14	6	Diesel	SS350GE03R31
DETROIT DIESEL	ISX	915	15	6	Diesel	SS350GE03R31
	Series 50	519	8.5	4	Diesel	SS350GE03R31
	Series 60	778	12.7	6	Diesel	SS350GB03R31
DEUTZ-MWM	8V-2000	976	16.0	8	Diesel	SS350GB03R31
	BF6L913	374	6.1	6	Diesel	SS175GB01R77
	BF8L513	779	12.8	8	Diesel	SS350GE01R85
	F12L413	1035	17.0	12	Diesel	SS350GE01R85
	F6L413	584	9.6	6	Diesel	SS175GB01R85
M.W.M	F6L912	345	5.7	6	Diesel	SS175GB01R77
	D234	1343	22.0	12		SS350GE01R77-02J
MACK	G232V8	720	11.8	8		SS350GE01R77-02J
	END465	465	7.6	4	Diesel	SS175GE01R77
VOLVO PENTA	END475	475	7.8	4	Diesel	SS175GE01R77
	D50A	313	5.1	6	Diesel	SS175GB01R77
	D70A	410	6.7	6	Diesel	SS175GB01R77
	TAMD163	983	16.1	6	Diesel	SS175GE03R29
	TAMD71B	411	6.7	6	Diesel	SS175GE01R85
	TD100GD100	410	6.7	6	Diesel	SS175GB01R77
	TD61	334	5.5	6	Diesel	SS175GB01R77
	TMD100A	586	9.6	6	Diesel	SS175GE01R85
WAUKESHA	TMD122	731	12.0	6	Diesel	SS175GE01R85
	197DLC	302	4.9	6	Diesel	SS175GE01R29
	6SRB	677	11.1	6	Nat. Gas	SS175GE03R29
	F11G (SI)	673	11.0	6	Nat. Gas	SS350GE03R29-02H
	F18GL (D)	1096	18.0	6	Nat. Gas	SS350GE03R31
	F476D	475	7.8	6	Diesel	SS175GE01R77-02J
WHITE ENGINES	H24GL (D)	1462	24.0	8L	Nat. Gas	SS350GE03R31-02H
	D-4800	478	7.8	6	Diesel	SS175GE03R29
	DRXB	474	7.8	6	Diesel	SS175GB03R31
	DWXC	358	5.9	6	Diesel	SS175GB03R31
	HXC	779	12.8	6	Gas	SS175GE03R29



# SS175/SS350 Series Air Starters

## SS175/SS350 Series Genuine Ingersoll-Rand Replacement Kits

Tune Up Kit Part Number	Description
SS175-TK2	SS175 Tune Up Kit
SS350-TK2	SS350 Tune Up Kit

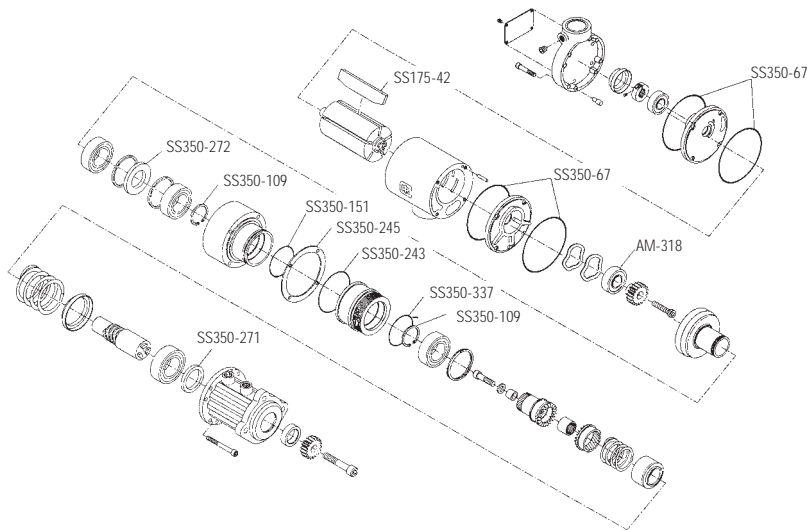

Exploded View of SS175-TK2 Part Location



SS175-TK2 Parts

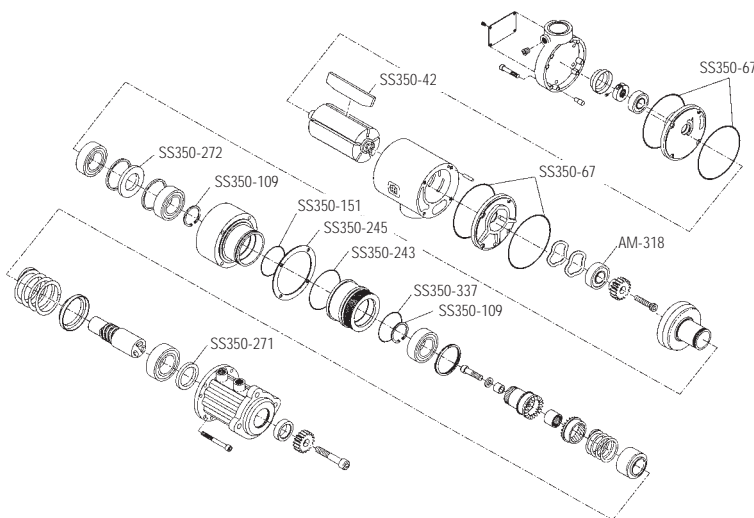

Exploded View of SS350-TK2 Part Location



SS350-TK2 Parts





## Air Starters

# 150BM Series

**#1** Starter in the  
oil and gas industries



**For engine displacement of:** Diesel-500 to 2000 CID (8 to 32 liters)  
Carburated-1000 to 4000 CID (16 to 64 liters)

### Features/Benefits

- 150BMG model sealed for use in gas or air applications
- Rugged 34 hp motor
- Multiple offset gear ratios: C = 2.69:1  
E = 3.46:1  
D = 3.94:1
- Backcap ports for injection lubricating

### Versatile

- Inertia and pre-engaged drives available
- Left- and right-hand rotation available
- 4 inlet, 4 exhaust, and 18 drive housing orientations
- 90-150 psi (6.2-10.3 bars) operation
- Inline and offset designs



IR's genuine 150BMGE21RH-6R remanufactured starter is shown mounted on a Detroit Diesel 12V-71R.



The 150BMGE21RH-6 starters are shown mounted on a Cummins KTA14-M3 and KTA19-M4I.



## 150BMG/150BMP Series DIMENSIONS

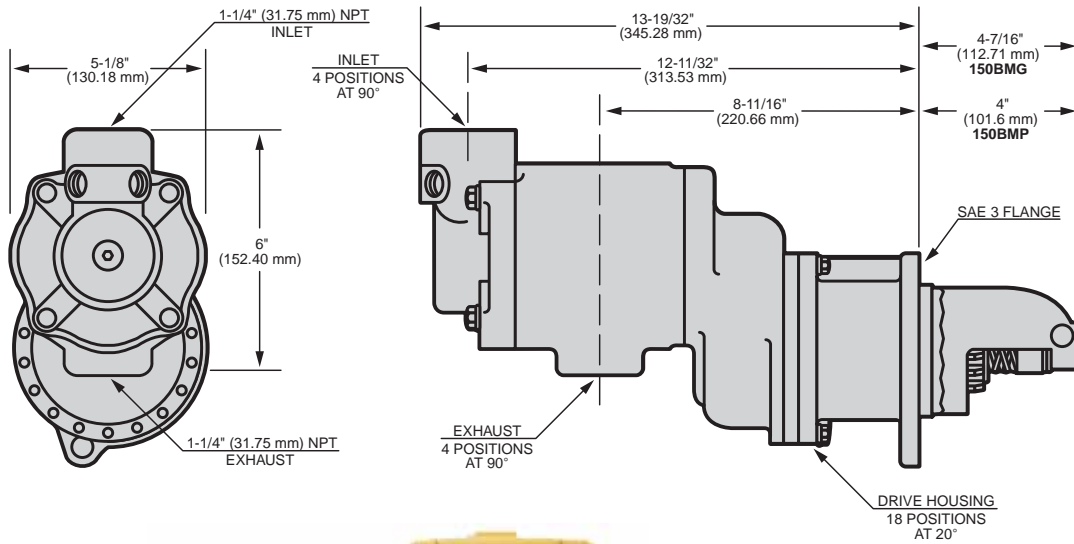

Weight lbs (kg)

150BMG	38 (17.2)
150BMP	40 (18.1)



## 150BMPD Series DIMENSIONS

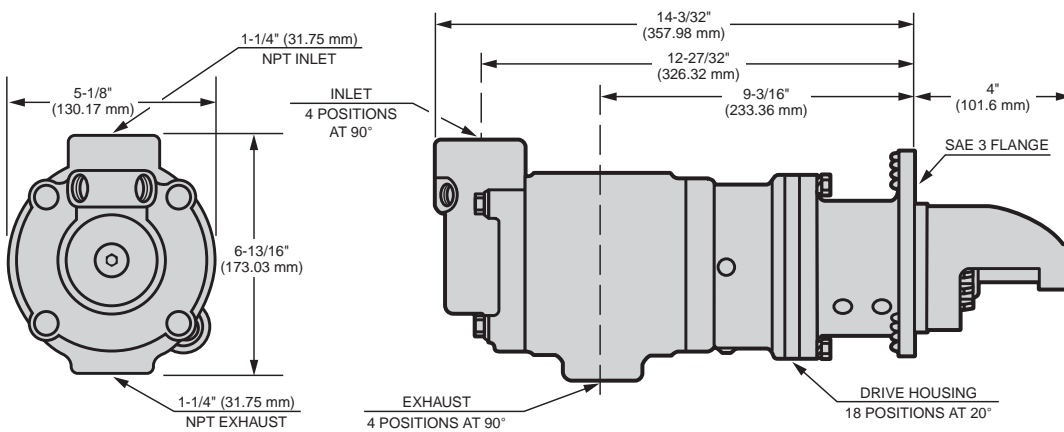

Weight lbs (kg)

150BMPD	40 (18.1)
---------	-----------



# 150BM Series

## 150BMGE/150BMPE Series Performance Information

Pressure PSI (bar)	Breakaway Torque ft-lb (Nm)	Speed @ Max HP RPM	Max Power HP (kw)	Flow @ Max HP SCFM (L/s)
90 (6.2)	100 (136)	1700	16 (12)	380 (179)
120 (8.3)	130 (176)	1900	24 (18)	500 (236)
150 (10.3)	155 (210)	2200	32 (24)	680 (321)

## 150BMPD Series Performance Information

Pressure PSI (bar)	Breakaway Torque ft-lb (Nm)	Speed @ Max HP RPM	Max Power HP (kw)	Flow @ Max HP SCFM (L/s)
90 (6.2)	110 (149)	1500	16 (12)	370 (175)
120 (8.3)	145 (196)	1700	24 (18)	500 (236)
150 (10.3)	175 (237)	1900	32 (24)	650 (307)







## 150BM Series Number of Starts per Tank

(Assuming 1-Second Crank Time @ 90 PSI)

<b>Max Tank Pressure (psi)</b>	300	16	25	33	41	49	57	66	74	20	<b>Max Tank Pressure (bar)</b>	
	270	14	21	29	36	43	50	57	64	18		
	240	12	18	25	31	37	43	49	55	16		
	210	10	15	20	26	31	36	41	46	14		
	180	8	12	16	20	25	29	33	37	12		
	150	6	9	12	15	18	21	25	28	10		
	120	4	6	8	10	12	14	16	18	8		
	90	2	3	4	5	6	7	8	9	6		
		40	60	80	100	120	140	160	180			
		151	227	302	378	454	529	605	680			
	<b>Tank Size</b>									<b>Gallons Liters</b>		

## 150BM Series Accessories

See catalog pages J-1 to J-18 for detailed Accessory information.

IR Part #	Description	Picture
1 150BM-A674	1 1/4" Muffler	
2 150BMP-1051B	1/4" 12 V Solenoid Valve	
3 150BMP-2451B	1/4" 24 V Solenoid Valve	
4 NL-24-8	In-Line Lubricator	
5 HDL2 (Stationary)	3/8" NPT Lubricator (1.3 cc)	
6 HDL3 (Transportation)	3/8" NPT Lubricator (0.4 cc)	
7 SMB-618	Push Button Valve	
8 SMB-G618	Push Button Valve For Natural Gas	

IR Part #	Description	Picture
9 SRV125T	1-1/4" Relay Valve For Vehicular Applications	
10 SRV150SS	1-1/2" Relay Valve For Stationary Gas Applications	
11 150BMP-1058	Gladhand	
12 150BMP-1064	1/8", 150 psi Pressure Gauge	
13 ST900-267-24	1-1/2" Strainer (300 Mesh)	
14 ST900-266-24	1-1/2" Strainer Element (300 Mesh)	
15 150BM-A735	Road Splash Deflector	

Red item numbers correspond to numbers in diagrams on page G-5.

# 150BM Series

## 150BMPE Typical Vehicular Installation

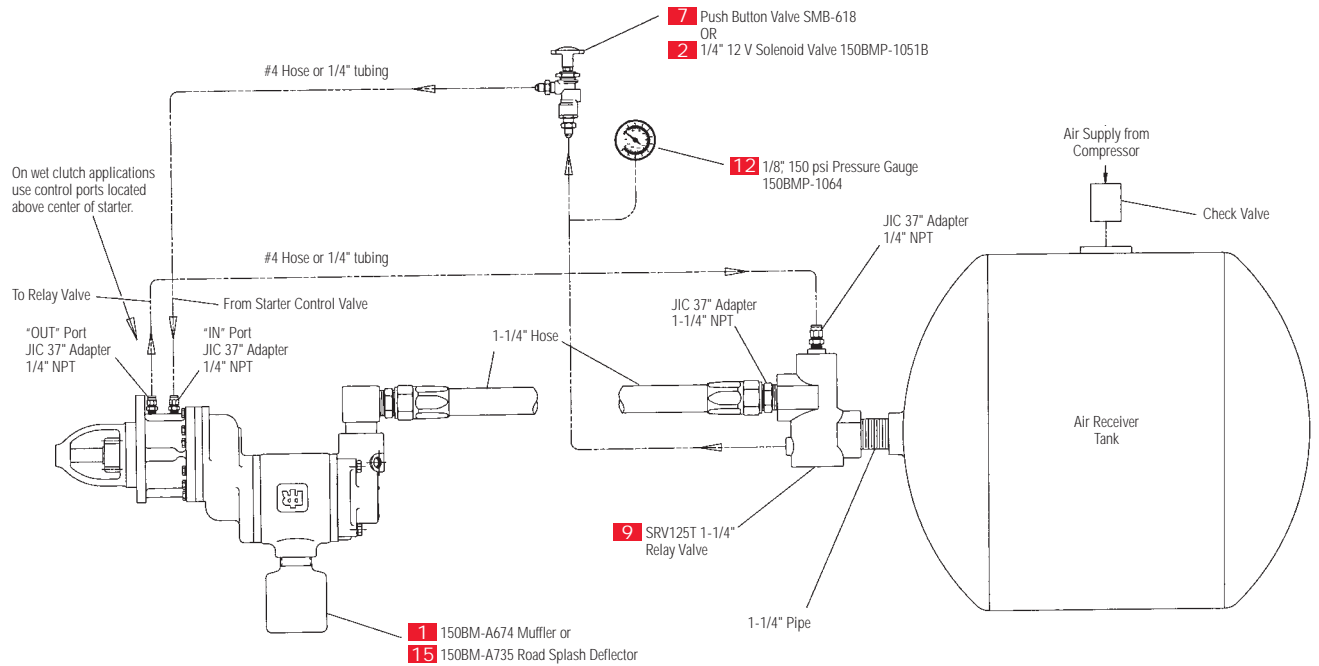

## 150BMG (Gas) Stationary Installation

For gas operation the exhaust outlet must be piped away to a safe location.

For natural gas operation, piped exhaust must be used and drive housing vent plug replaced with suitable hose which connects into piped exhaust system.

For air operation a muffler or splash guard deflector must be used.

NOTE: Use sealant on all pipe connections.

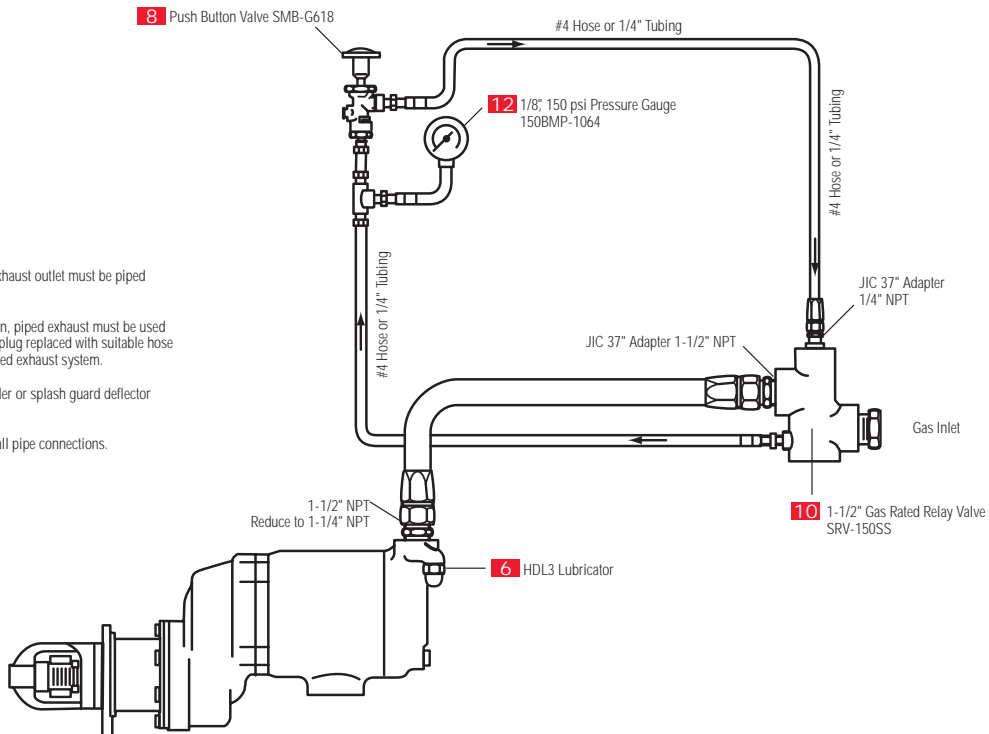

# Air Starters

**Bold Model Numbers** indicate that a remanufactured model is available with the same part number (add an "R" to the number).

**Most Obsolete Units** ▶

## 150BM Crossover Model Numbers

150BM Available Units	150LF Crossovers	Obsolete Units	Obsolete Units	Obsolete Units	Obsolete Units
150BMGE21RH-6		101BMPC78RH-31	10BMB21RH-31		
150BMGE12RH-13		150BME12RH-13	150BME12RH-13	10BMB12RH-13	9BMA43RH-13
<b>150BMGE21LH-11</b>	150LFGE21LH11-000	150BME21LH-11	150BME21LH-11	10BMB21LH-11	9BMB31LH-11
<b>150BMGE21LH-11</b>	<b>150LFGE21LH11-020</b>	150BMGE21LH-11	150BMGE21LH-11	10BMB22LH-8	9BMA32LH-8
150BMGE21LH-32					
<b>150BMGE21RH-6</b>	150LFE21RH6-020	150BME21RH-6	150BME21RH-6	10BMB21RH-6	9BMA331RH-6
150BMGE21RH6-22R	150LFGE21RH6-000	150BME21RH-17	150BME21RH-17		
<b>150BMGE22RH-5</b>	<b>150LFGE22RH5-020</b>	150BME22RH-5	150BME22RH-5		
150BMGE22RH5-10D		150BMGE22RH-5	150BMGE22RH-5	10BMB12RH-13	9BMA43RH-13
<b>150BMPD88L54-020</b>					
<b>150BMPD88R54-020</b>		150BMPD88R-46	150BMPD89RH-46	150BMPAC03R85	
150BMPE81R15-00N	150LFPE81R15-020				
<b>150BMPD88L54-11A</b>		150BMPD89LH-50	150BMPD89LH-50	101BMPC78LH-11	
150BMPE88L54-12E		150BMPE88L-11	15BMPE78LH-11		
150BMPE88L54-13E		150BMPE88L-11	150BMPE83LH-11	10BMB21LH-11	9BMB31LH-11
<b>150BMPE88L54-200</b>	150LFPE88L54-000				
150BMPE88L54-20N					
150BMPE88L54-22N					
150BMPE88L54-33A					
150BMPE88L54-33C					
150BMPE88R51-200	150LFPE88R51-020				
150BMPE88R53-000		150BMPE88R-53	150BMPE78RH-53	101BMPC78RH-38	
150BMPE88R53-020	150LFPE88R53-020	150BMPE88R-53	150BMPE78RH-5	10BMB22RH-5	9BMA32RH-5
150BMPE88R53-12F					
150BMPE88R53-200					
<b>150BMPE88R53-300</b>					
<b>150BMPE88R54-000</b>	150LFPE88R54-000	150BMPE88R-44	150BMPE78RH-44	101BMPB78RH-44	
<b>150BMPE88R54-00N</b>	<b>150LFPE88R54-00N</b>	150BMPE88R-54	150BMPE78RH-54		
<b>150BMPE88R54-02E</b>	150LFPE88R54-02E		150BMPE78RH-6	101BMPC78RH-6	
150BMPE88R54-12C					
150BMPE88R54-12D	150LFPE88R54-12D				
150BMPE88R54-12E	150LFPE88R54-12E				
<b>150BMPE88R54-200</b>	<b>150LFPE88R54-200</b>				
150BMPE88R54-20E					
150BMPE88R54-220					
<b>150BMPE88R54-22E</b>					
<b>150BMPE88R54-300</b>	<b>150LFPE88R54-300</b>				
150BMPE88R54-32P					

### 150BM SERIES MODEL CODING

150 BMG E 21 RH 6 0 2 F

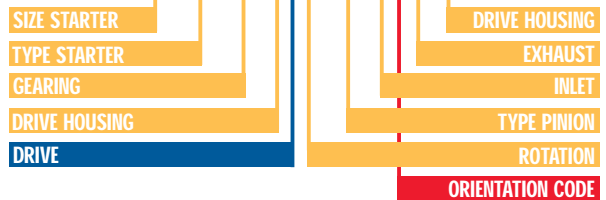

# 150BM Series

*This chart is a condensed list of engines that can be cranked with an IR starter. For a complete list, please contact IR.*

## 150BM Series Engine Selection Guide

Manufacturer	Engine	CID	Liter	CYL	Type	Vane Starter
CATERPILLAR	3126	439	7.2	6	Diesel	150BMPE81R15
	3176	629	10.3	8	Diesel	150BMPE88R54
	3406	893	14.6	6	Diesel	150BMPE88R54
	3408	1099	18	8	Diesel	150BMPE88R54
	D-334	638	10.5	6	Diesel	150BMPE88R53
	D-336	700	11.5	8	Diesel	150BMPE88R53
	D-343	893	14.6	6	Diesel	150BMPE88R54
	D-346	1191	19.5	8	Diesel	150BMPE88R54
	G-342	1246	20.4	6	Nat. Gas	150BMPE88R54
CES-AJAX	DP125	2205	36.1	1	Nat. Gas	150BMGE21LH-11
	DP165	2826	46.3	1	Nat. Gas	150BMGE21LH-11
	DPC180	2826	46.3	1	Nat. Gas	150BMGE21LH-11
	DPC60	850	14	1	Nat. Gas	150BMGE21LH-11
CLIMAX	K67	1616	26.5	6	Gas	150BMPE88R53
	K75	1855	30.4	6	Gas	150BMPE88R53
	R165	1238	20.3	6	Gas	150BMPE88R53
CONTINENTAL	R602	602	9.9	6	Gas	150BMPE88R53
	R6513	513	8.4	6	Gas	150BMPE88R53
	U6501	501	8.2	6	Gas	150BMPE88R53
CUMMINS	ISC	506	8.3	6	Diesel	150BMPE88R53
	ISL	549	9	6	Diesel	150BMPE88R53
	N-14 SERIES	855	14	6	Diesel	150BMPE88R54
	N-855 SERIES	855	14	6	Diesel	150BMPE88R54
	ISM	659	10.8	6	Diesel	150BMPE88R54
	ISX	915	15	6	Diesel	150BMPE88R54
DETROIT DIESEL	6V-71	426	7	6	Diesel	150BMGE21RH6
	6V-92	552	9	6	Diesel	150BMGE21RH6
	Series 50	519	8.5	4	Diesel	150BMPE88R54
	Series 60	778	12.7	6	Diesel	150BMPE88R54
EMD GM	12-645	7740	126.8	12	Diesel	2-150BMPD88R54
	12-710	8520	139.6	12	Diesel	2-150BMPD88R54
	16-645	10320	169.1	16	Diesel	2-150BMPD88R54
	16-710	11360	186.2	16	Diesel	2-150BMPD88R54
	20-645	12900	211.4	20	Diesel	2-150BMPD88R54
	20-710	14200	232.7	20	Diesel	2-150BMPD88R54
	8-645	5160	84.6	8	Diesel	150BMPD88R54
	8-710	5680	93.1	8	Diesel	150BMPD88R54
WAUKESHA	145GZ	817	13.4	6	Nat. Gas	150BMGE22RH5
	6GAK	784	12.8	6	Nat. Gas	150BMGE22RH5
	6WAK	1197	19.6	6	Nat. Gas	150BMGE21RH6
	F1197G	1197	19.6	6	Nat. Gas	150BMGE21RH6
	F119G	1197	19.6	6	Nat. Gas	150BMGE21RH-6
	H1077G	1077	17.6	8	Nat. Gas	150BMGE21RH6
	H24L	1462	24	8	Nat. Gas	150BMGE21RH6
	H867D	866	14.2	8	Diesel	150BMPE88R53
WHITE ENGINES	DFXD	855	14	6	Diesel	150BMPE88R54
	DFXE	895	14.7	6	Diesel	150BMPE88R54



# 150BM Series Air Starters

## 150BM Series Genuine Ingersoll-Rand Replacement Kits

Tune Up Kit Part Number	Description
150BM-TK2	150BM Products
150LF-TK2	150LF Products (uses 150LF-42 vanes)
150LF-TK1	150 Motor Gasket Kit for all vane motor 150 products
150BMPD-TK1	150BMPD Products

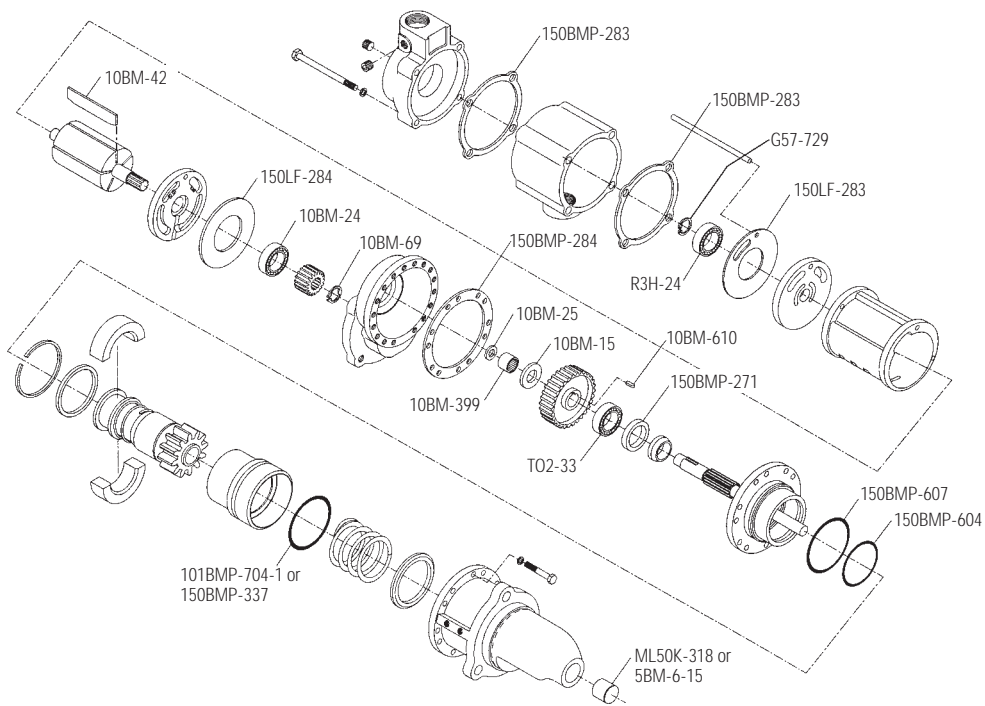

Exploded View of 150BM-TK2 Part Location



150BM-TK2 Parts



150LF-TK1 Parts





## Air Starters

# SS800 Series



**For engine displacement of:** Diesel—1000 to 20,000 CID (16 to 320 liters)  
Carburated—2000 to 40,000 CID (32 to 640 liters)

### Features/Benefits

- All models sealed for use in air or gas applications
- Offset design for simple mounting
- Powerful 80 hp motor
- Multiple offset gear ratios: B = 2.18:1  
C = 2.53:1  
D = 3.44:1
- Backcap ports for injection lubricating

### Versatile

- Inertia (SS810) and pre-engaged (SS815, SS825, and SS850) starters available
- 4 inlet, 4 exhaust, and 16 drive housing orientations
- 90-150 psi (6.2-10.3 bars) operation
- Remanufactured starters available
- Left- and right-hand rotation available



*IR's genuine SS810GB03R31 inertia remanufactured starter is shown mounted on a Detroit Diesel 16V-71R.*



*The SS815GB03R31 starter is shown mounted on a Cummins KTA50-M2 piped with the IR SRV150 Relay Valve.*

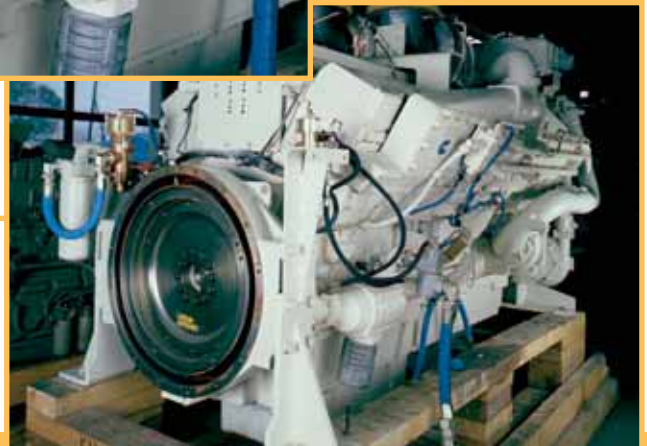

## SS810G Series DIMENSIONS

	Weight lbs (kg)
SS810G	93 (42.2)

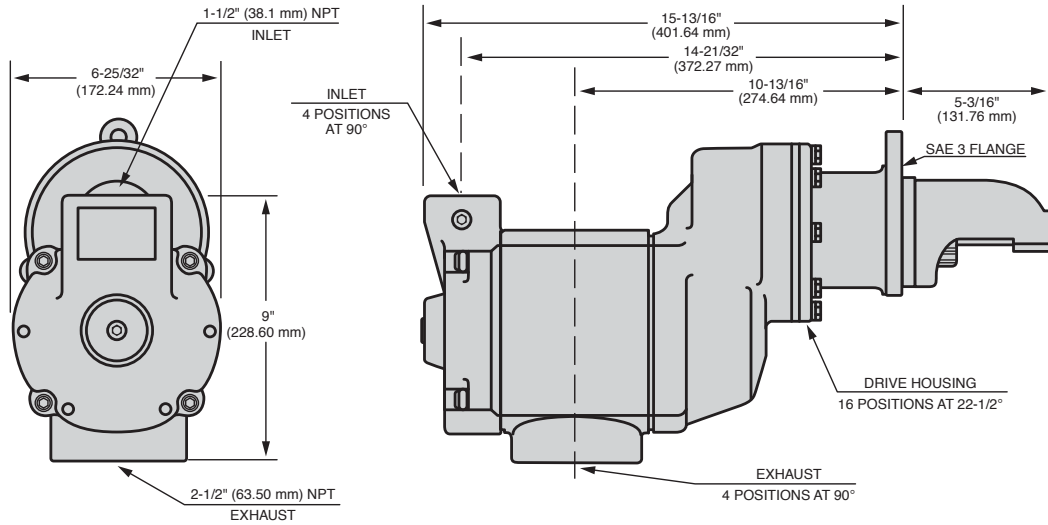

## SS815G and SS825G Series DIMENSIONS

	Weight lbs (kg)
SS815G	93 (42.2)
SS825G	95 (43.1)

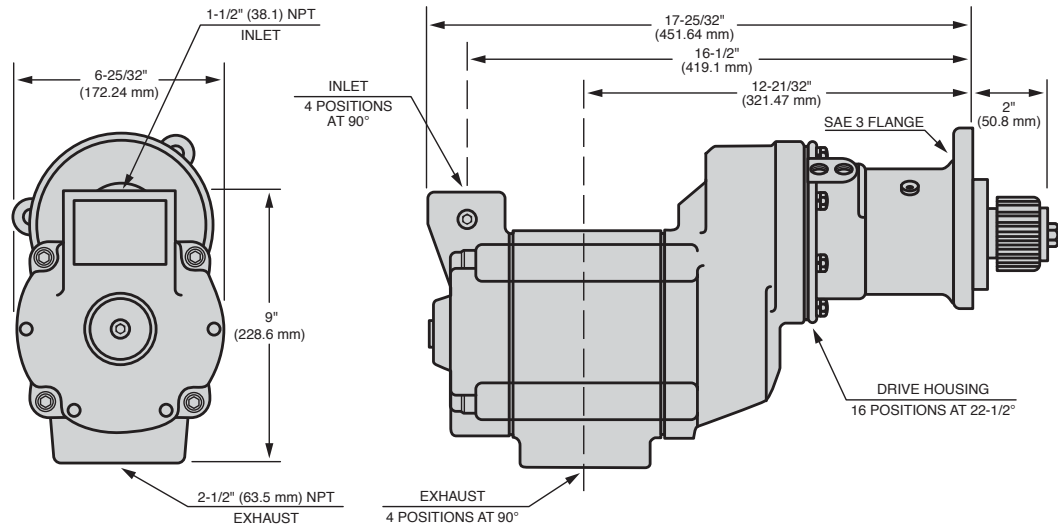

## SS850G Series DIMENSIONS

	Weight lbs (kg)
SS850G	123 (55.8)

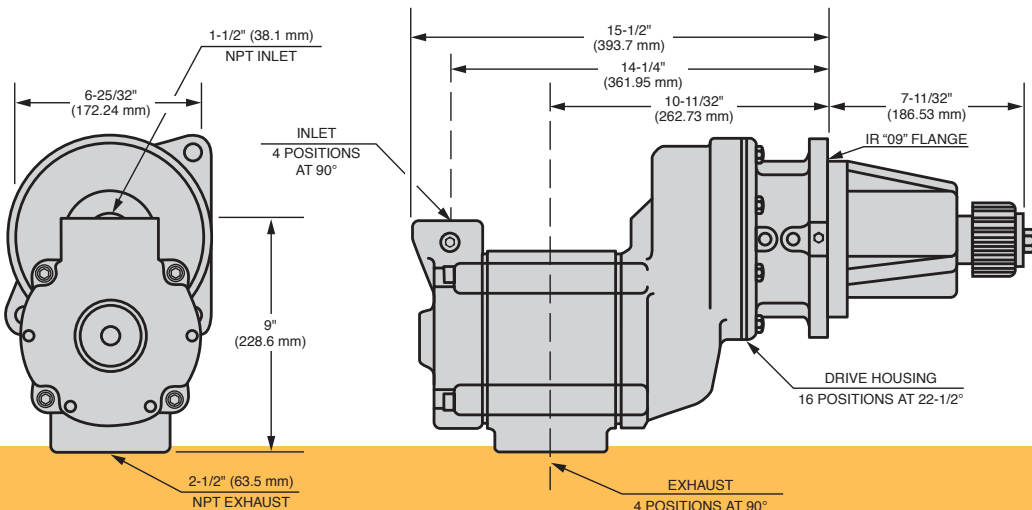

# SS800 Series

## SS810 and SS815 Series Performance Information

Pressure PSI (bar)	Breakaway Torque ft-lb (Nm)	Speed @ Max HP RPM	Max Power HP (kw)	Flow @ Max HP SCFM (L/s)
90 (6.2)	170 (230)	2700	45 (34)	1100 (519)
120 (8.3)	205 (278)	2800	58 (43)	1250 (590)
150 (10.3)	250 (339)	3200	75 (56)	1700 (802)

## SS825 Series Performance Information

Pressure PSI (bar)	Breakaway Torque ft-lb (Nm)	Speed @ Max HP RPM	Max Power HP (kw)	Flow @ Max HP SCFM (L/s)
90 (6.2)	200 (271)	2300	45 (34)	900 (425)
120 (8.3)	240 (325)	2400	58 (43)	1100 (519)
150 (10.3)	300 (407)	2700	75 (56)	1350 (637)

## SS850 Series Performance Information

Pressure PSI (bar)	Breakaway Torque ft-lb (Nm)	Speed @ Max HP RPM	Max Power HP (kw)	Flow @ Max HP SCFM (L/s)
90 (6.2)	260 (352)	1600	45 (34)	800 (378)
120 (8.3)	340 (461)	1800	58 (43)	1000 (472)
150 (10.3)	415 (562)	1900	75 (56)	1275 (602)

## SS800 Series Number of Starts per Tank

(Assuming 2-Second Crank Time @ 90 PSI)

300	5	6	7	8	10	11	12	13	20	
270	4	5	6	7	8	10	11	12	18	
240	4	5	5	6	7	8	9	10	16	
210	3	4	5	5	6	7	8	8	14	
180	2	3	4	4	5	5	6	7	12	
150	2	2	3	3	4	4	5	5	10	
120	1	2	2	2	2	3	3	3	8	
90	1	1	1	1	1	1	2	2	6	
	80	100	120	140	160	180	200	220		
	302	378	454	529	605	680	756	832		
										Gallons
										Liters
										Tank Size

## SS800 Series Accessories

See catalog pages J-1 to J-18 for detailed Accessory information.

IR Part #	Description	Picture
<b>1</b> SS800-A674	2-1/2" Muffler	
<b>2</b> 150BMP-1051B	1/4" 12 V Solenoid Valve	
<b>3</b> 150BMP-2451B	1/4" 24 V Solenoid Valve	
<b>4</b> NL-24-8	In-Line Lubricator	
<b>5</b> HDL2 (Stationary)	3/8" NPT Lubricator (1.3 cc)	
<b>6</b> HDL3 (Transportation)	3/8" NPT Lubricator (0.4 cc)	
<b>7</b> SMB-618	Push Button Valve	
<b>8</b> SMB-G618	Gas Rated Push Button Valve	

IR Part #	Description	Picture
<b>9</b> SRV150	1-1/2" Relay Valve For Air Applications	
<b>10</b> SRV150SS	1-1/2" Gas Rated Relay Valve	
<b>11</b> 150BMP-1058	Gladhand	
<b>12</b> 150BMP-1064	1/8", 150 psi Pressure Gauge	
<b>13</b> ST900-267-24	1-1/2" Strainer (300 Mesh)	
<b>14</b> ST900-267-32	2" Strainer (300 Mesh)	
<b>15</b> ST900-266-24	1-1/2" Strainer Element (300 Mesh)	
<b>16</b> ST900-266-32	2" Strainer Element (300 Mesh)	

Red item numbers correspond to numbers in diagrams on page H-5.

# SS800 Series

## SS810 Typical Stationary Installation

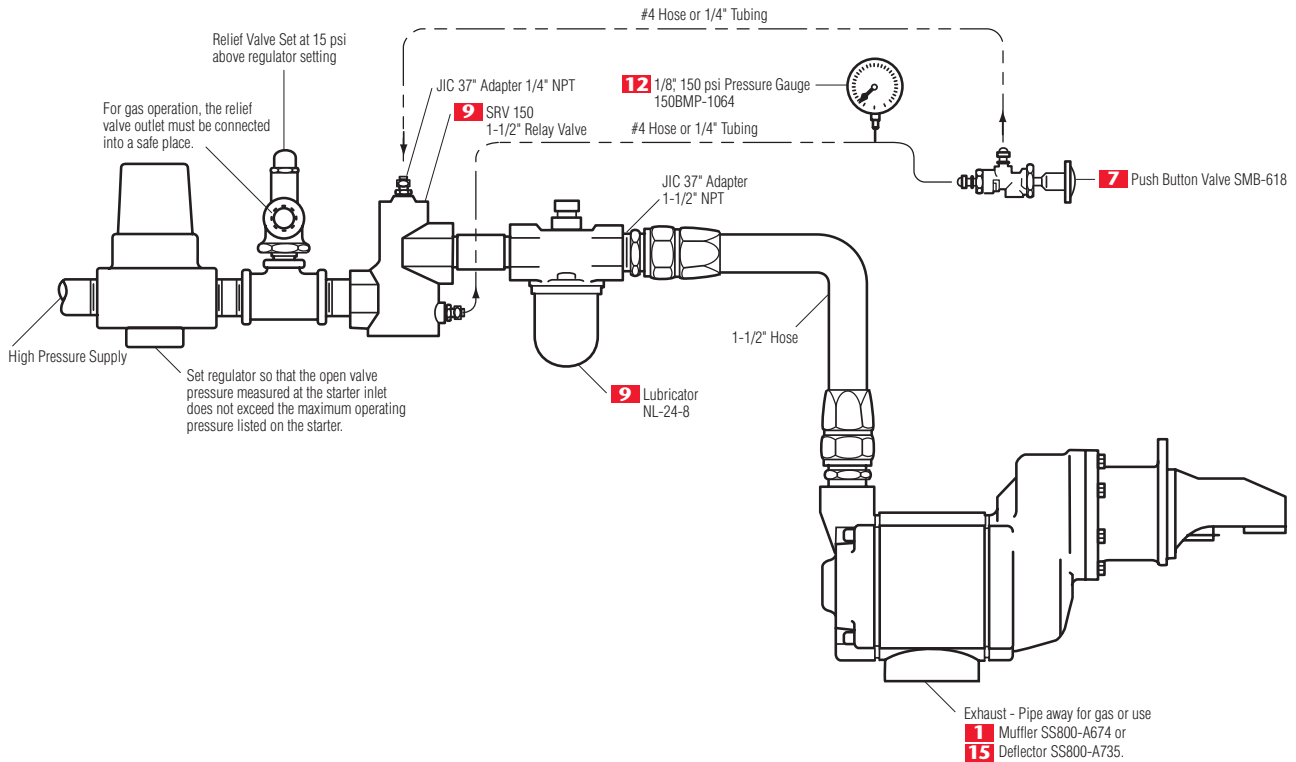

## SS815/SS825/SS850 Typical Stationary Installation

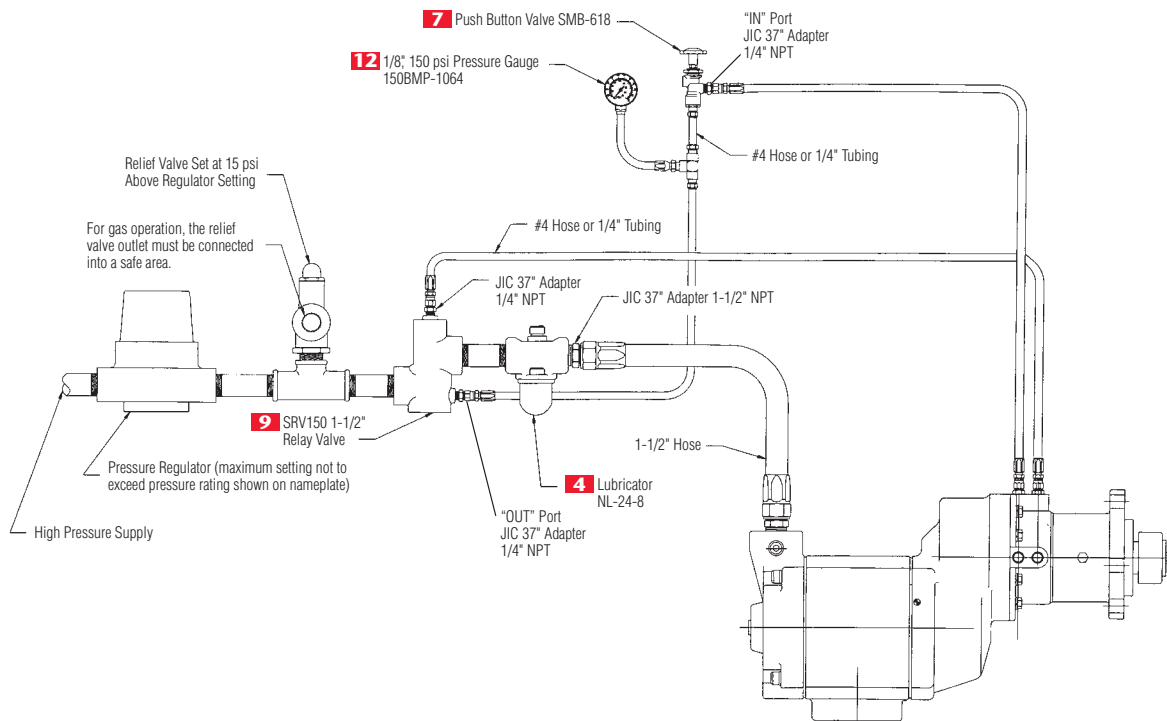

# Air Starters

**Bold Model Numbers** indicate that a remanufactured model is available with the same part number (Add an "R" to the number).

**Most Obsolete Units** ▶

## SS800 Crossover Model Numbers

SS800 Series Available Units	SS800 Obsolete Units	SS660 Obsolete Units	SM450 Obsolete Units	20BM Obsolete Units
<b>SS810GB03L32</b>	SS800GB03L32	SS660LB991A02	SM450LB991A02	20BMB47LH-4
<b>SS810GB03R31</b>		SS660RB991A01	SM450RB991A01	20BMB41RH-1
SS810GB03R31-02M-F				
SS810GB03R31-13B				
SS810GB03R31-13C				
SS810GB03R31-310				
SS810GB03R31-31A				
SS810GB03R31-31P				
SS815FGB03L32				
<b>SS815FGB03R31</b>				
<b>SS815GB03L32</b>	SS800GB03L32	SS660LB991A02	SM450LB991A02	20BMB47LH-4
SS815GB03L32-02G				
SS815GB03L32-22H				
SS815GB03L92-1738				
<b>SS815GB03R25R</b>				
<b>SS815GB03R31</b>				
SS815GB03R31-02B				
SS815GB03R31-02G				
SS815GB03R31-02H				
SS815GB03R31-02K				
SS815GB03R31-11C				
SS815GB03R31-12G				
SS815GB03R31-1323	SS800BR/VRSM-962			
SS815GB03R31-21G				
SS815GB03R31-220				
SS815GB03R31-23C				
SS815GB03R31-23D				
SS815GB03R31-23K				
SS815GB03R31-310				
SS815GB03R91	SS800GB03R91	SS660RB991A08		
SS815GBDPJ3R493				
SS825FGC03L26				
<b>SS825FGC03R25</b>				
<b>SS825GC03L26</b>		SS660LB981A04	SM450LB981A04	20BM21LH-22
SS825GC03L26-1162				
SS825GC03L26-1163				
SS825GC03L26-11E				
SS825GC03L52-21C				
SS825GC03L52-23E				
<b>SS825GC03R25</b>		SS660RB981A03	SM450RB981A03	20BMB21RH-19
SS825GC03R25-02K				
SS825GC03R25-21G				
SS825GC03R25-310				
SS825GC03R25-31D				
SS825GC03R25SR-02G				
SS825GC03R31				
SS850GD09L52		SS660LD971A06	SM450LD971A06	20BMD52LH-26
SS850GD09R51		SS660RD971A05	SM450RD971A05	20BMD52RH-25

### SS800 SERIES MODEL CODING

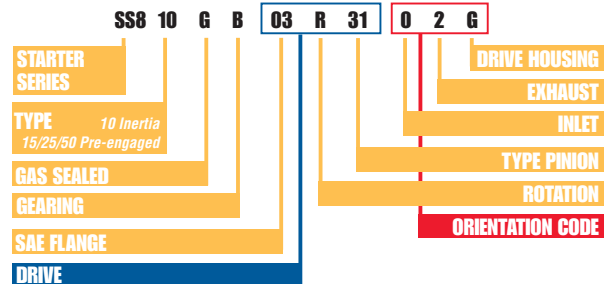

# SS800 Series

*This chart is a condensed list of engines that can be cranked with an IR starter. For a complete list, please contact IR.*

## SS800 Series Engine Selection Guide

Manufacturer	Engine	CID	Liter	CYL	Type	Vane Starter
<b>CATERPILLAR</b>	3412	1649	27.0	12	Diesel	SS815GB03R31
	3512	3158	51.8	12	Diesel	SS815GB03R31
	3516	4210	69.0	16	Diesel	SS815GB03R31
	G3612	13527	221.7	12	Nat. Gas	SS815GB03R31
	G3616	18036	295.6	16	Nat. Gas	2 - SS815GB03R31
	G-398	2946	48.3	12	Nat. Gas	SS815GB03R31
	G-399	3927	64.4	16	Nat. Gas	SS815GB03R31
<b>CES-BESSEMER</b>	GMXE	9420	154.0	12	Nat. Gas	SS850GD09L52
	GMXF	9420	154.0	12	Nat. Gas	SS850GD09L52
	GMXH	9420	154.4	12	Nat. Gas	SS850GD09L52
<b>CUMMINS</b>	K19 SERIES	1150	18.8	6	Diesel	SS815GB03R31
	K38 SERIES	2300	37.7	12	Diesel	SS815GB03R31
	K50 SERIES	3067	50.3	16	Diesel	SS825GC03R31
	QSK45	2746	45.0	12	Diesel	SS815GB03R31
	QST30	1861	30.0	12	Diesel	SS815GB03R31
	VT28	1710	28.0	12	Diesel	SS815GB03R31
	VTA28-C	1710	28.0	12	Diesel	SS815GB03R31
<b>Detroit Diesel</b>	12V-92	1104	18.1	12	Diesel	SS815GB03R31
	16V-149	2384	39.1	16	Diesel	SS815GB03R31
	16V-71	1136	18.6	16	Diesel	SS815GB03R31
	16V-92	1472	24.1	16	Diesel	SS815GB03R31
	12V4000	2928	48	12	Diesel	SS815GB03R31
	16V4000	3904	64	16	Diesel	SS815GB03R31
<b>EMD GM</b>	12-278	6809	111.6	12	Diesel	SS850GD09R51
	12-498	7576	124.1	12	Diesel	SS850GD09R51
<b>WAUKESHA</b>	7044	7040	116.0	12V	Nat. Gas	SS815GB03R31
	12VAT25D	10784	176.7	12	Diesel	SS825GC03R25
	12VAT27	17397	285.0	16	Diesel	SS825GC03R25
	12VAT27GL	13048	214.0	12V	Nat. Gas	SS825GC03R25
	16AT27GL	17397	285.0	16	Nat. Gas	SS825GC03R25
	16VAT25GL	14378	235.6	16	Nat. Gas	SS825GC03R25
	7042G (SI/L)	7040	115.0	12V	Nat. Gas	SS815GB03R31
	8LAT25D	7189	117.8	8	Nat. Gas	SS815GB03R31
	8LAT25GL	7189	117.8	8	Nat. Gas	SS815GB03R31
	8LAT27GL	8699	143.0	8	Diesel	SS815GB03R31
	F1197D	1197	19.6	6	Diesel	SS815GB03R31
	F1905D	1905	31.2	6	Diesel	SS815GB03R31
	F2895G (SI)	2894	47.4	6	Nat. Gas	SS815GB03R31
	F2896D	2894	47.4	6	Diesel	SS815GB03R31
	F3335D	3335	54.7	6	Diesel	SS815GB03R31
	F3336D	3335	54.7	6	Diesel	SS815GB03R31
	F3521G (SI)	3520	58.0	6L	Nat. Gas	SS815GB03R31
	L5788D	5788	94.8	12	Diesel	SS825GC03R25
	L5792D	5788	94.8	12	Diesel	SS825GC03R25
P9390G	9388	154.0	16	Nat. Gas	SS825GC03R25	



# SS800 Series Air Starters

## SS800 Series Genuine Ingersoll-Rand Replacement Kits

Tune Up Kit Part Number	Description
SS800-TK2	SS815 and SS825 Tune Up Kit
SS810-TK2	SS810 Tune Up Kit
SS850-TK2	SS850 Tune Up Kit

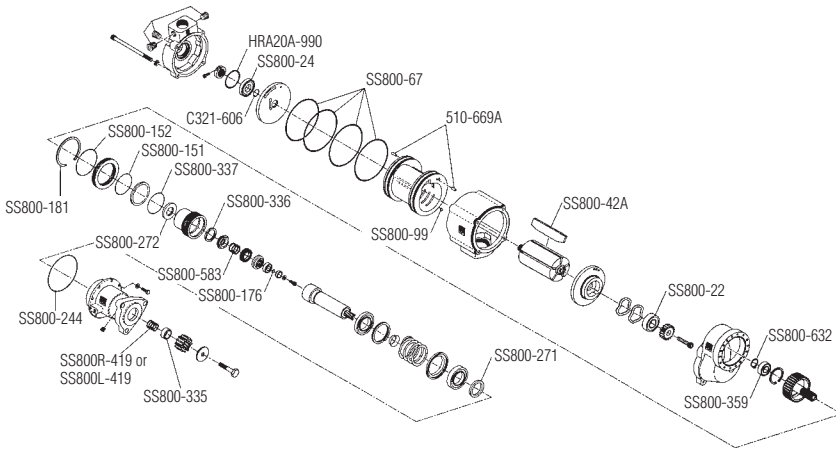

Exploded View of SS800-TK2 Part Location



SS800-TK2 Parts

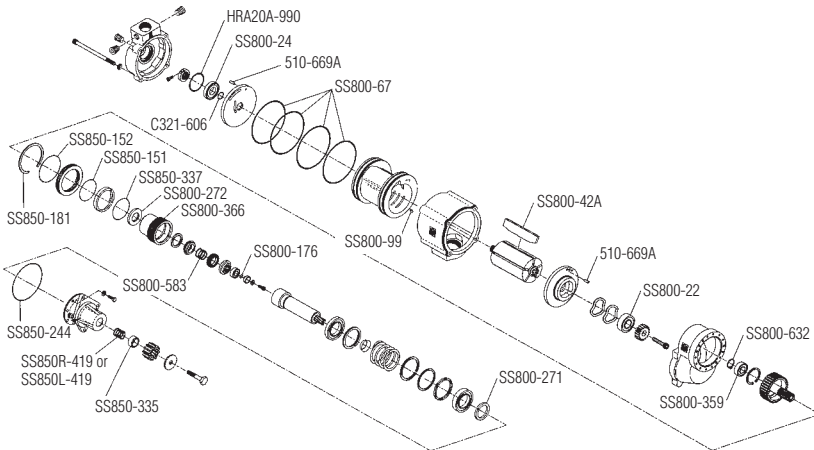

Exploded View of SS850-TK2 Part Location



SS810-TK2 Parts





## Air Starters

# TS700/TS900/TS1400 Series



## Starters for Gas Turbine Engines

### Features/Benefits

- No oil in drive air is necessary
- Splash lubrication system internally lubricates the planetary gears and motor bearings
- Air cooling extends bearing and seal life
- No internal or external shut-off devices

### Versatile

- Multiple spline pinions
- Multiple gear ratios for matching the optimum engine characteristics
- Multiple flange options
- Gas-sealed for application flexibility

## TS700/TS900/TS1400 SERIES MODEL CODING

TS 7 99 B B E E - L E

TURBINE OR  
RECIPROCATING ENGINE

MODEL

ARC: HALF – 50  
FULL – 99

CLUTCH TYPE

GEAR RATIO

E = ELBOW  
M = V CLAMP

PINION ROTATION R = RIGHT  
L = LEFT

SPLINE

FLANGE

## TS725/TS750GBBE-LE DIMENSIONS

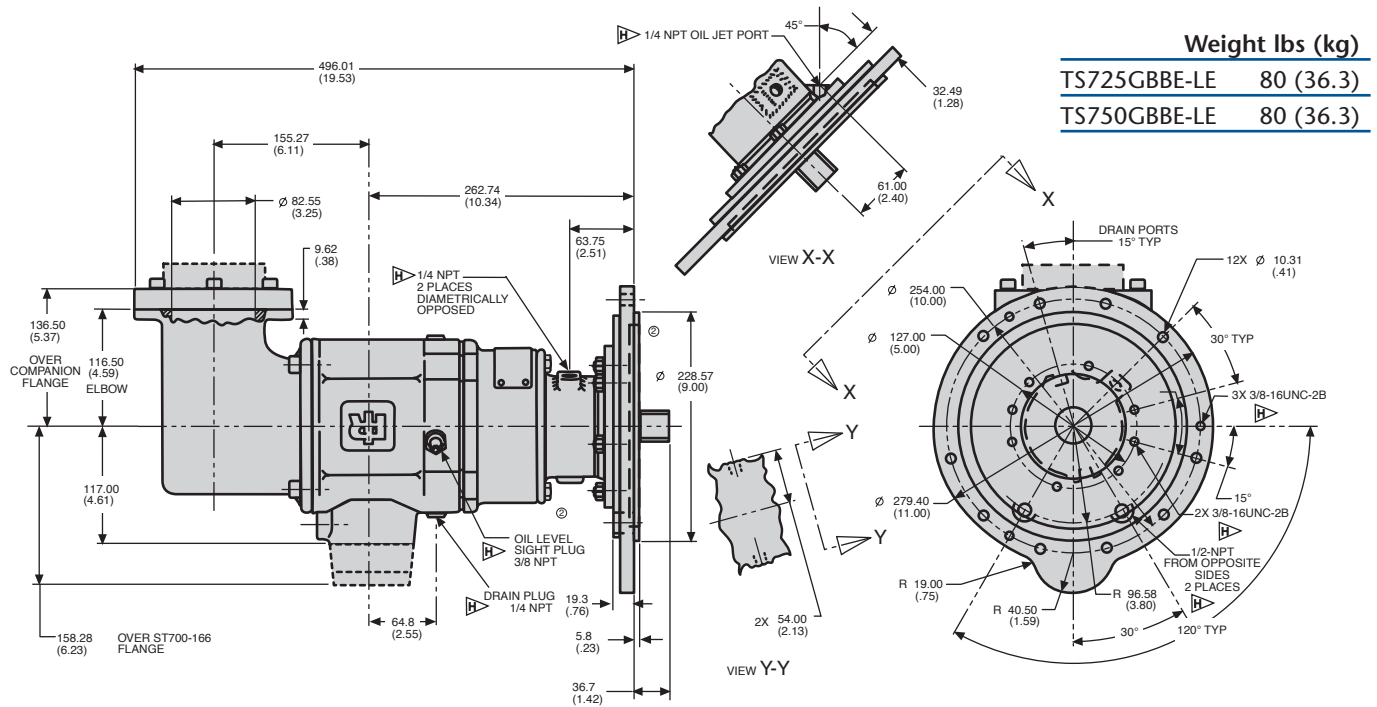

## TS725GBDE-LE DIMENSIONS

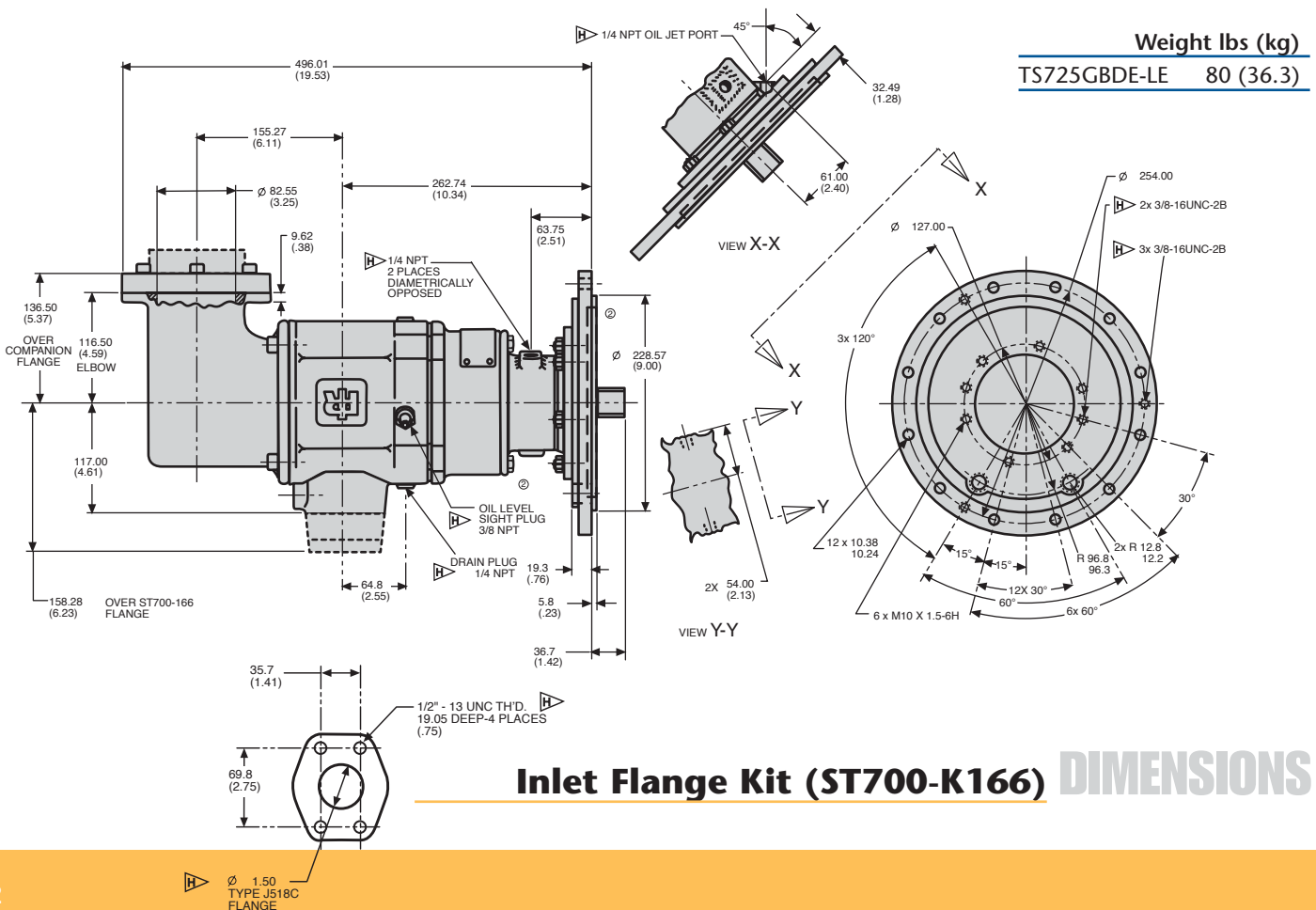

## Inlet Flange Kit (ST700-K166) DIMENSIONS

## TS799BBEF-LE DIMENSIONS

Weight lbs (kg)

TS799BBEF-LE 70 (31.8)

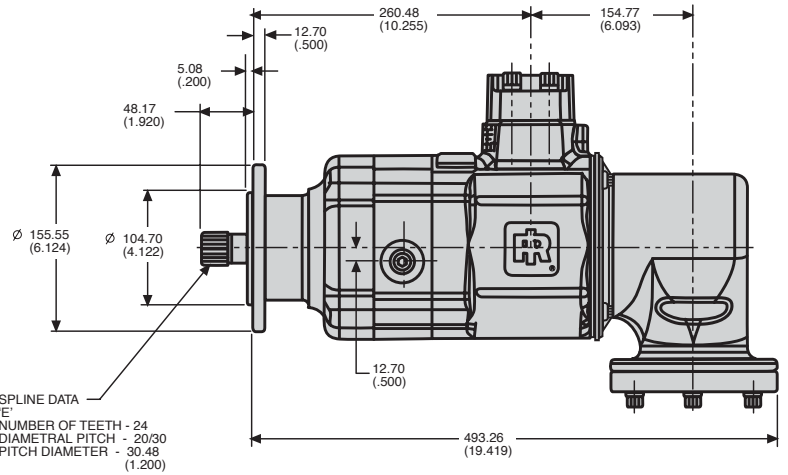
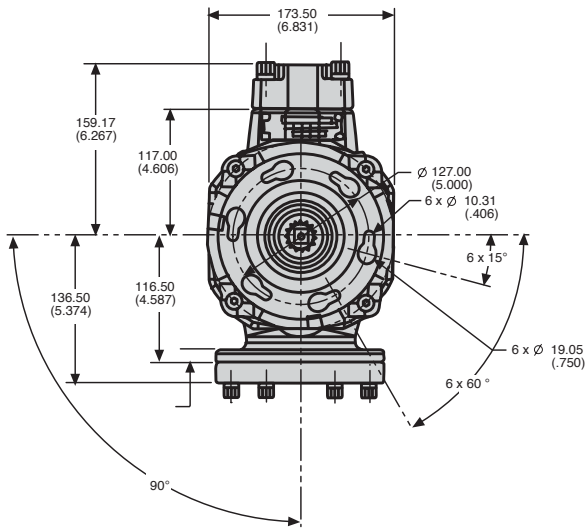

## TS799BBEF-LM DIMENSIONS

Weight lbs (kg)

TS799BBEF-LM 62 (28.1)

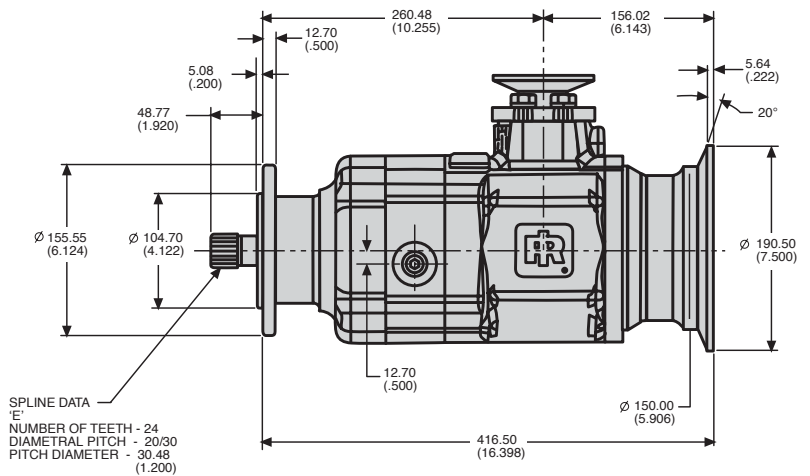
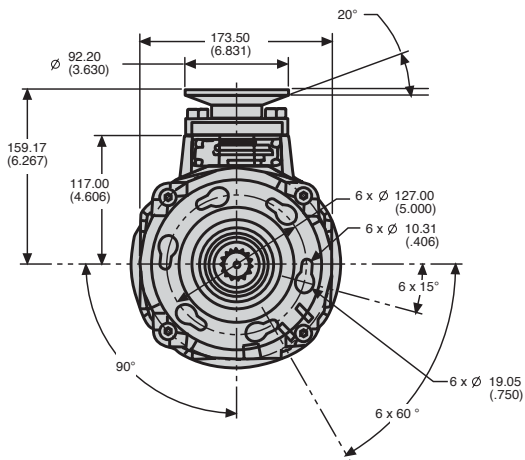

## TS799GBFD-L DIMENSIONS

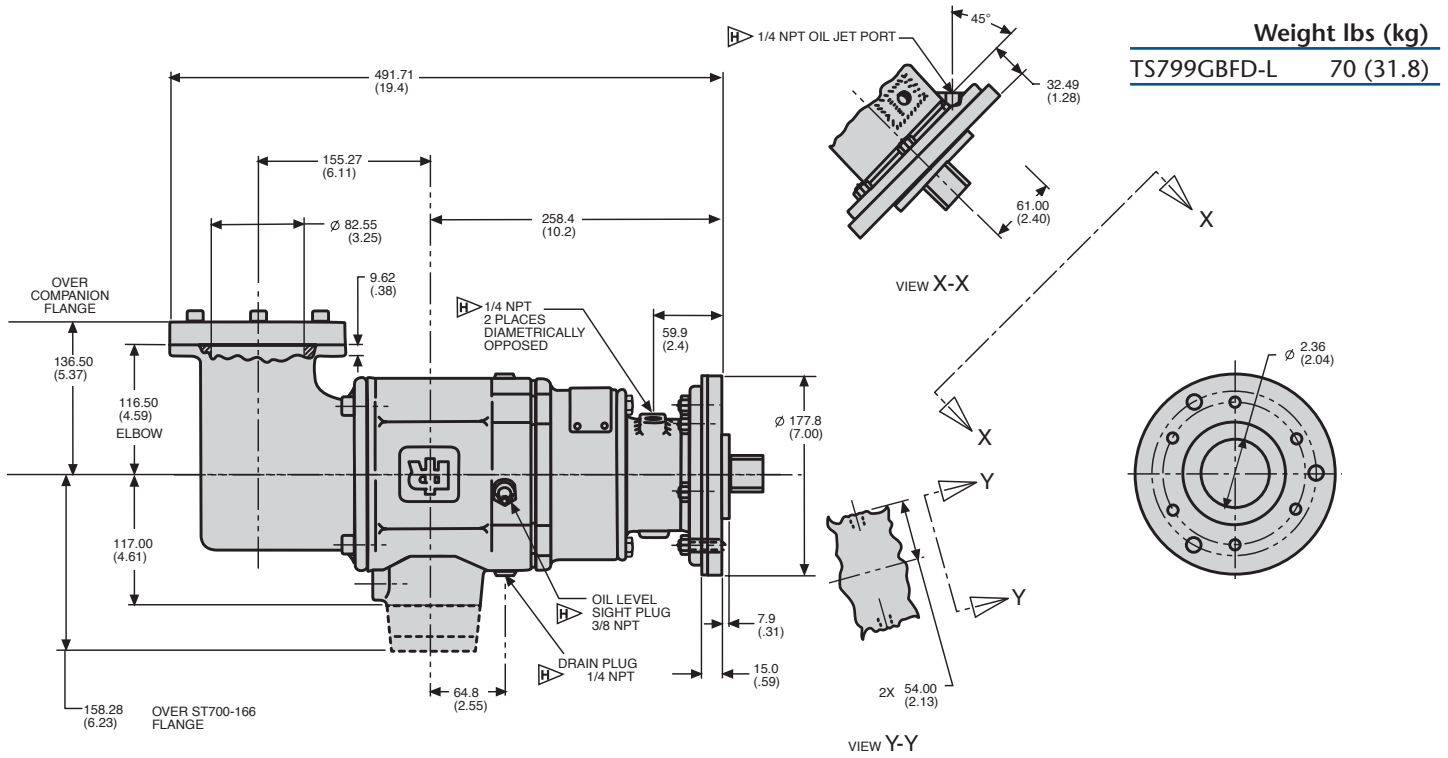

## TS999GZCD-LE DIMENSIONS

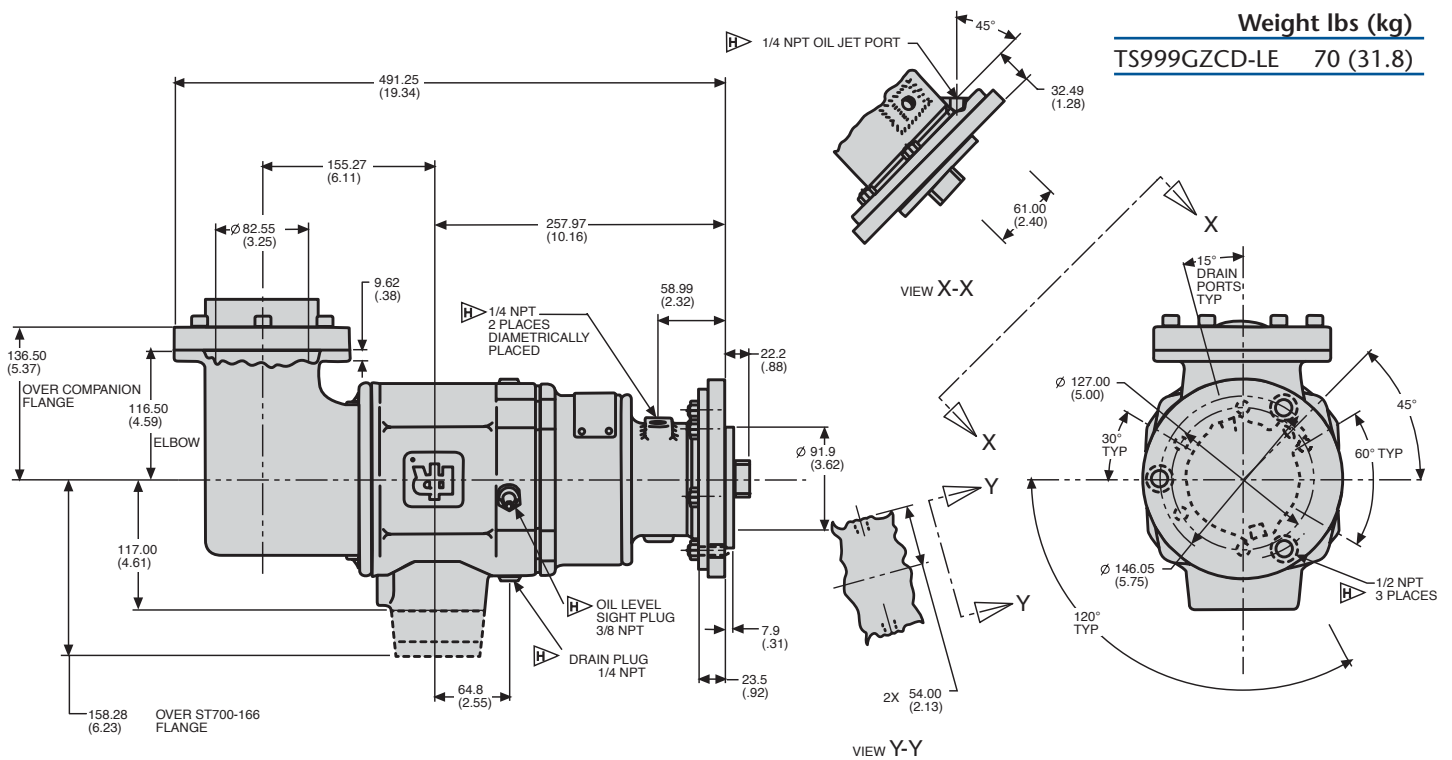

# TS700/TS900/TS1400 Series

Engine Starting Systems

## TS999GZFA-L DIMENSIONS

Weight lbs (kg)	
TS999GZFA-L	58 (26.3)

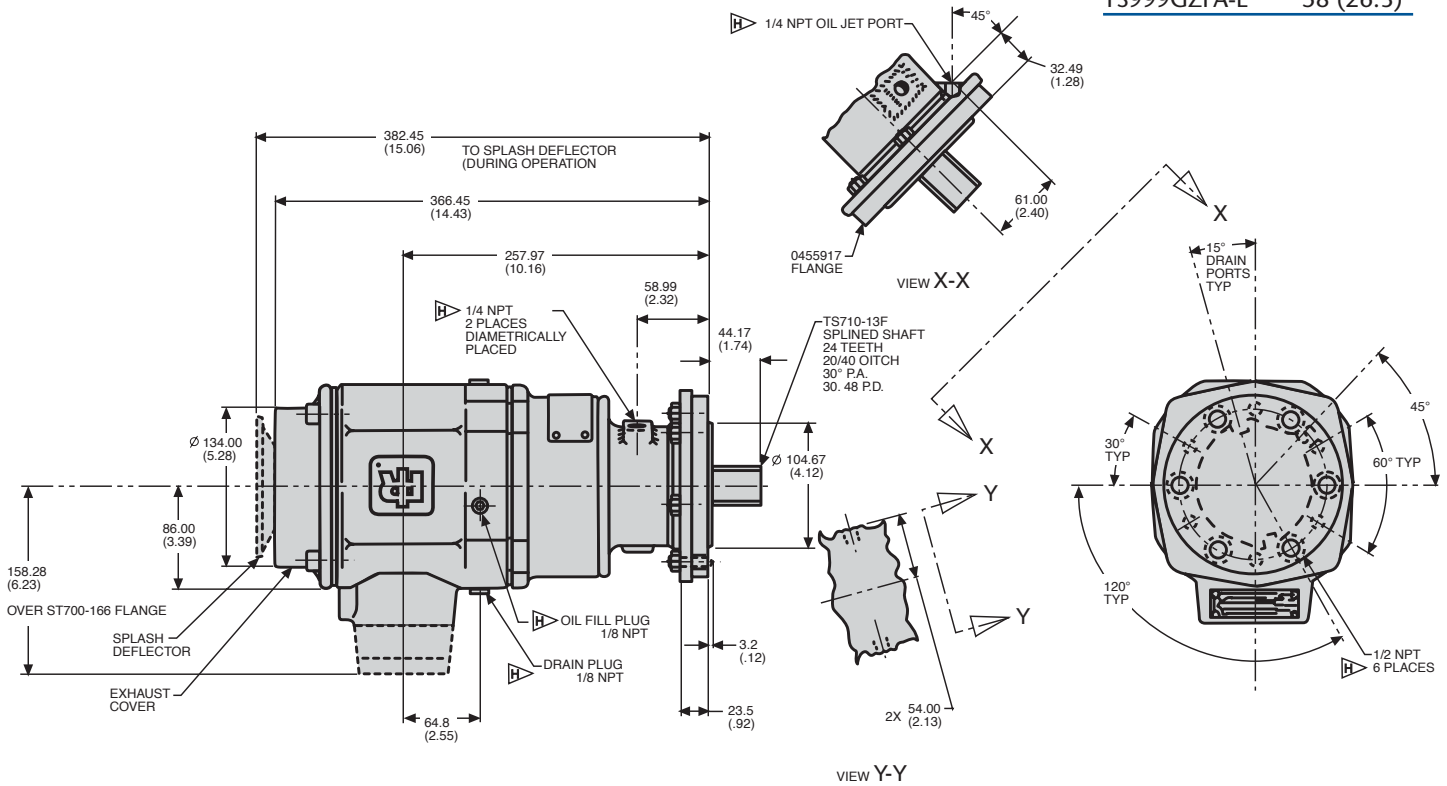

## TS1400 Turbine Units DIMENSIONS

Weight lbs (kg)	
TS1400	124 (56.2)

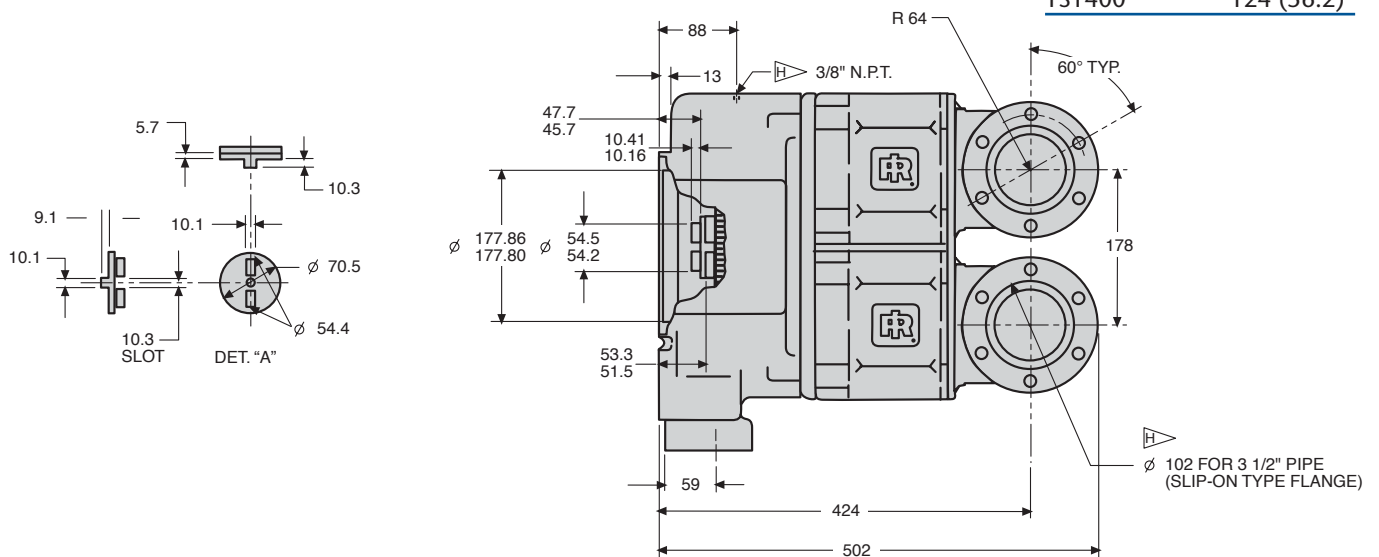

## TS725 Performance Information

Pressure PSI (bar)	Breakaway Torque ft-lb (Nm)	Speed @ Max HP RPM	Max Power HP (kw)	Flow @ Max HP SCFM (L/s)
90 (6.2)	110 (149)	2000	18 (13)	330 (156)
150 (10.3)	180 (243)	2300	40 (30)	515 (243)
225 (15.5)	270 (365)	2500	65 (49)	750 (354)

## TS750 Performance Information

Pressure PSI (bar)	Breakaway Torque ft-lb (Nm)	Speed @ Max HP RPM	Max Power HP (kw)	Flow @ Max HP SCFM (L/s)
90 (6.2)	170 (230)	2200	30 (22)	850 (401)
120 (8.3)	240 (325)	2300	50 (37)	990 (467)
150 (10.3)	300 (407)	2500	70 (52)	1210 (571)

## TS799G Performance Information

Pressure PSI (bar)	Breakaway Torque ft-lb (Nm)	Speed @ Max HP RPM	Max Power HP (kw)	Flow @ Max HP SCFM (L/s)
60 (4.1)	250 (339)	2400	55 (41)	1050 (496)
90 (6.2)	310 (420)	2500	70 (52)	1400 (661)

## TS799B Performance Information

Pressure PSI (bar)	Breakaway Torque ft-lb (Nm)	Speed @ Max HP RPM	Max Power HP (kw)	Flow @ Max HP SCFM (L/s)
150 (10.3)	570 (773)	2500	130 (97)	2200 (1038)

## TS999 Performance Information

Pressure PSI (bar)	Breakaway Torque ft-lb (Nm)	Speed @ Max HP RPM	Max Power HP (kw)	Flow @ Max HP SCFM (L/s)
90 (6.2)	125 (169)	5500	71 (53)	1300 (614)

## TS1400 Performance Information

IR Part Number	Solar Part Number	Max Pressure PSI (bar)	Breakaway Torque ft-lb (Nm)	Speed @ Max HP RPM	Max Power HP (kw)	Flow @ Max HP SCFM (L/s)	Motor Arc
TS1401-102	190475-102	225 (15.5)	420 (567)	3100	124 (93)	1700 (802)	25%
TS1435	190475-301	225 (15.5)	459 (620)	3882	141 (105)	1900 (896)	35%
TS1450	190475-401	150 (10.3)	506 (683)	3034	146 (109)	2500 (1179)	50%

# TS700/TS900/TS1400 Series

Engine Starting Systems

*This chart is a condensed list of engines that can be cranked with an IR starter. For a complete list, please contact IR.*

## TS Engine Selection Guide

Engine	IR Part Number	Solar Part Number	Max Pressure PSI (bar)
<b>Solar Saturn</b>	TS725GBBE-LE	190716-200	225 (15.5)
	TS725GBDE-LE	190716-100	225 (15.5)
	TS750GBBE-LE	-	150 (10.3)
<b>Solar Centaur</b>	TS1435	190475-301	225 (15.5)
	TS1450	190475-401	180 (12.2)
	TS1401-102	190475-102	225 (15.5)
<b>Solar Taurus</b>	TS1435	190475-301	225 (15.5)
	TS1450	190475-401	180 (12.2)
	TS1401-102	190475-102	225 (15.5)
<b>Allison 570</b>	TS799GBFD-L	-	90 (6.2)
<b>Allison 501-KC</b>	TS999GZFA-L	-	90 (6.2)
<b>Allison 501-KB</b>	TS999GZFA-L	-	90 (6.2)
<b>Garret IE831</b>	TS999GZCD-LE	-	90 (6.2)
<b>Pratt &amp; Whitney GG3/F13 , GG4/G14</b>	TS799BBEF-LE	-	150 (10.3)
	TS799BBEF-LM	-	150 (10.3)

## TS700/TS900 Output Spline Data

TS Part Number	Shaft Output Part Number	Teeth	Diametral Pitch	Pressure Angle	Pitch Diameter
<b>TS725GBBE-LE</b>	TS710-13E	24	20/30	30	30.48
<b>TS725GBDE-LE</b>	TS710-13E	24	20/30	30	30.48
<b>TS750GBBE-LE</b>	TS710-13E	24	20/30	30	30.48
<b>TS799BBEF-LE</b>	TS799-18E	24	20/30	30	30.48
<b>TS799BBEF-LM</b>	TS799-18E	24	20/30	30	30.48
<b>TS799GBFD-L</b>	4612834	16	20/30	30	20.32
<b>TS999GZCD-LE</b>	4612834	16	20/30	30	20.32
<b>TS999GZFA-L</b>	TS710A-13F	24	20/40	30	30.48









# TS700/TS900/TS1400 Series Air Starters

## TS700 & TS1400 Series Genuine Ingersoll-Rand Replacement Kits

Tune Up Kit Part Number	Description
TS1400-TK1	Seal and O-Ring Kit
TS1401-RM1	Seals, Bearings, and 2- 25% Arc Motors
TS1401-RM2	Seals, Bearings, and 2- 99% Arc Motors
TS1401-RM3	Seals, Bearings, and 2- 35% Arc Motors
TS1401-RM4	Seals, Bearings, and 2- 50% Arc Motors
TS1401-TK1	Seal and O-Ring Kit
TS700-RM1	Bearing and O-Ring Kit (Includes TS700-TK1)
TS700-TK1	O-Ring Kit

## TS700/TS900/TS1400 Series Accessories

IR Part #	Description	Picture
1 SRV150	1-1/2" Relay Valve For Air	
2 SRV150SS	1-1/2" Gas Rated Relay Valve	
3 150BMP-1064	1/8", 150 psi Pressure Gauge	
4 ST900-267-24	1-1/2" Strainer (300 Mesh)	

IR Part #	Description	Picture
5 ST900-267-32	2" Strainer (300 Mesh)	
6 ST900-266-24	1-1/2" Strainer Element (300 Mesh)	
7 ST900-266-32	2" Strainer Element (300 Mesh)	

**See catalog pages J-1 to J-18 for detailed Accessory information.**





### Accessories Index By Description

Accessory Description	IR Part #	Page Number
Relay Valves	SRV100 SRV125 SRV125T SRV150 SRV150SS SRV150-TK3	J-3 – J-4
Solenoid Control Valves	150BMP-1051B 150BMP-2451B 150BMP-6451B 150BMP-A1051C 150BMP-B2451	J-5
Solenoid Control Valves	ST400-A339M ST400-C339 ST400-K619	J-6
Push Button Control Valves	SMB-618 SMB-G618 White Push Button Replacement Black Push Button Replacement	J-7
Air Strainers	ST900-267-16 ST900-267-24 ST900-267-32 ST900-267-64	J-8 – J-9
Mufflers	3BM-WM07 3BM-A674 150BM-A674 SS350-A674 ST500-674 SS800-A674	J-10
Regulators	NR-24-8 NR24-TK1	J-11 – J-12
In-Line Lubricators	NL-8-8 NL-24-8	J-13 – J-14
One-Shot Lubricators	HDL2 HDL3 HDL2 Replacement Kit HDL3 Replacement Kit	J-15 J-15 J-15
Road Splash Deflectors	150BM-A735 SS350-A735 ST500-A735 SS800-A735	J-16
Exhaust Tube Kit	ST500-K740	J-16
Liquid Sealant	SMB-431 SMB-441	J-16
Check Valves	150BMP-1056 150BMP-1054 ST400-1056	J-17
Drain Valve	150BMP-1067	J-17
Gladhand Coupling	150BMP-1058	J-18
Pressure Gauges	150BMP-1064 150BMP-1064L	J-18

# Accessories Index

## Accessories Index By IR Part Number

IR Part #	Accessory Description	Page Number
150BM-A674	Muffler	J-10
150BM-A735	Road Splash Deflector	J-16
150BMP-1051B	Solenoid Control Valve	J-5
150BMP-1054	Check Valve	J-17
150BMP-1056	Check Valve	J-17
150BMP-1058	Gladhand Coupling	J-18
150BMP-1064	Pressure Gauge	J-18
150BMP-1064L	Pressure Gauge	J-18
150BMP-1067	Drain Valve	J-17
150BMP-2451B	Solenoid Control Valve	J-5
150BMP-6451B	Solenoid Control Valve	J-5
150BMP-A1051C	Solenoid Control Valve	J-5
150BMP-B2451	Solenoid Control Valve Angle Mounting Bracket	J-5
3BM-A674	Muffler	J-10
3BM-WM07	Muffler	J-10
HDL2	One-Shot Lubricator	J-15
HDL2-TK1	HDL2 Replacement Kit	J-15
HDL3	One-Shot Lubricator	J-15
HDL3-TK1	HDL3 Replacement Kit	J-15
NL-24-8	In-Line Lubricator	J-13 – J-14
NL-8-8	In-Line Lubricator	J-13 – J-14
NR-24-8	Regulators	J-11 – J-12
NR24-TK1	NR-24-8 Tune Up Kit	J-11 – J-12
SMB-431	Liquid Sealant	J-16
SMB-441	Liquid Sealant	J-16

IR Part #	Accessory Description	Page Number
SMB-618	Push Button Control Valve	J-7
SMB-619	White Push Button Replacement	J-7
SMB-620	Black Push Button Replacement	J-7
SMB-G618	Push Button Control Valve	J-7
SRV100	Relay Valve	J-3 – J-4
SRV125	Relay Valve	J-3 – J-4
SRV125F	Relay Valve	J-3 – J-4
SRV125T	Relay Valve	J-3 – J-4
SRV150	Relay Valve	J-3 – J-4
SRV150SS	Relay Valve	J-3 – J-4
SRV150-TK3	Relay Valve Tune Up Kit	J-3 – J-4
SS350-A674	Muffler	J-10
SS350-A735	Road Splash Deflector	J-17
SS800-A674	Muffler	J-10
SS800-A735	Road Splash Deflector	J-17
ST400-1056	Check Valve	J-17
ST400-A339M	Solenoid Control Valve	J-6
ST400-C339	Solenoid Control Valve	J-6
ST400-K619	Solenoid Control Valve ST400 Repair Kit	J-6
ST500-674	Muffler	J-10
ST500-A735	Road Splash Deflector	J-16
ST500-K740	Exhaust Tube Kit	J-16
ST900-267-16	Air Strainer	J-8 – J-9
ST900-267-24	Air Strainer	J-8 – J-9
ST900-267-32	Air Strainer	J-8 – J-9
ST900-267-64	Air Strainer	J-8 – J-9

Note: All dimensions shown are for reference only. Specifications subject to change without notice.

# Relay Valves

Ingersoll-Rand Relay Valves provide immediate response to assure Air Starter disengagement and prevent damage to the pinion or flywheel ring gear. The aluminum die cast housing resists abrasion and corrosion while the stainless steel piston return spring will not rust from moisture in the air line.



SRV150



SRV150SS



SRV125F

## Specifications

- Maximum Operating Pressure = 225 psi (15.5 bar)
- Operating Temperature Range = -20 to 250°F (-29 to 121°C)
- Flow/Pressure Drop shown on CSR-352:  $C_v = 28.5$

## Specifications

IR Part Number	NPT Size Inlet – Outlet	Weight – lb (kg)	Description
SRV100	1" – 1"	3.10 (1.41)	3BMG, 5BMG, SS175G Relay Valve
SRV125	1-1/4" – 1-1/4"	2.90 (1.32)	150BM, SS350G, 150T Relay Valve
SRV125T	1-1/4" – 1-1/4"	2.90 (1.32)	150BM, SS350G, 150T Relay Valve for Transportation
SRV150	1-1/2" – 1-1/2"	2.70 (1.22)	SS800, ST700, ST900, ST600 Relay Valve
SRV150SS	1-1/2" – 1-1/2"	7.15 (3.24)	SS800, ST700, ST900 Relay Valve for Natural Gas Use
SRV125F	1-1/4" Flanged	7.40 (3.36)	150T/150BM Transportation Relay/Solenoid Valve

Inlet Pressure vs. Pilot Pressure to Open

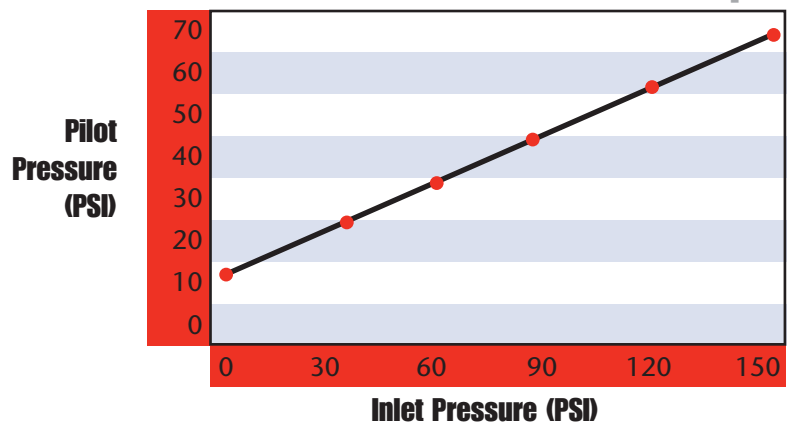

# Relay Valves

## Relay Valves DIMENSIONS

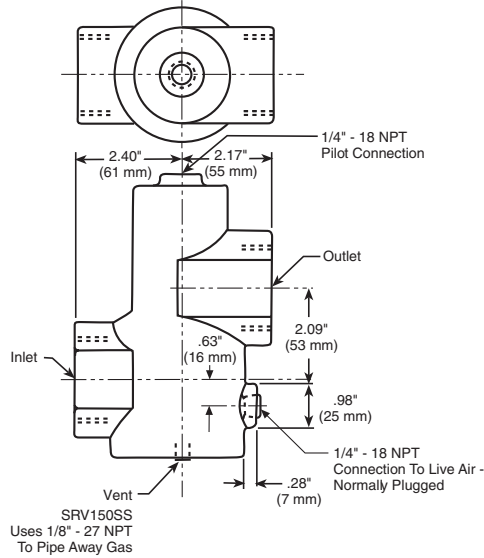
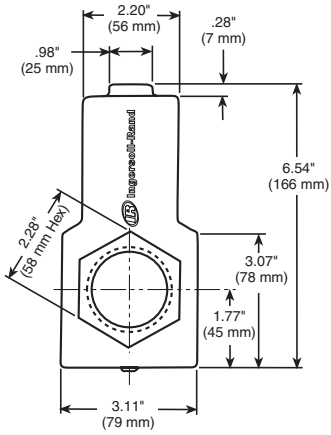

SRV150

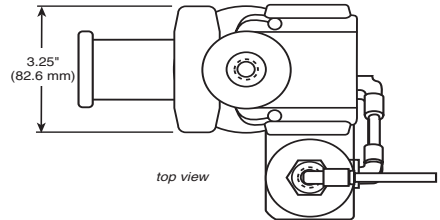
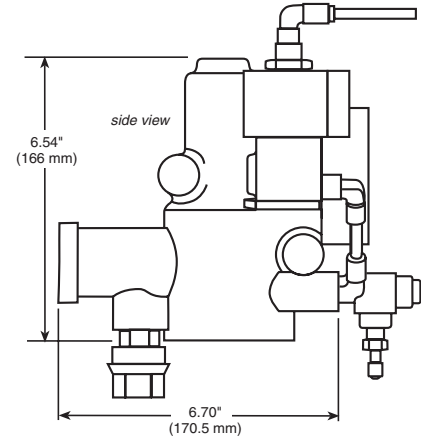

SRV125F

## Relay Valves Genuine Ingersoll-Rand Replacement Kits

### Tune Up Kit Part Number

### Description

SRV150-TK3

For use with SRV100, SRV125, SRV125T, SRV150, and SRV150SS Relay Valves

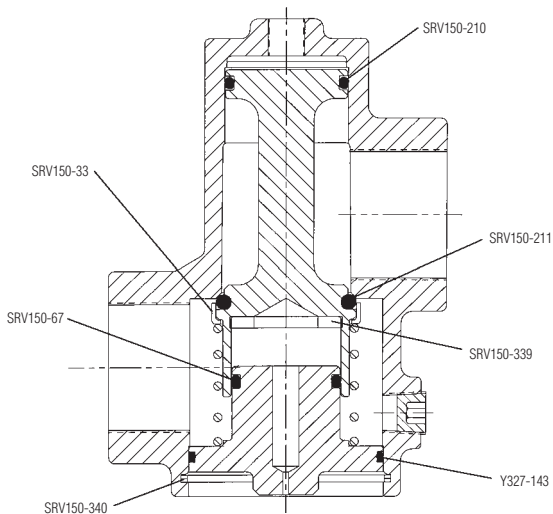

Cross-Section of SRV150-TK3 Part Location



SRV-TK3 Parts

# Solenoid Control Valves

These DC electrically actuated valves are designed for pilot operation of the IR relay valve and are approved for applications affected by the U.S. Department of Transportation safety codes.

## Specifications

- Valve Type: Three-way normally closed  $C_v$  Factor: 0.21
- Power Consumption: 25 watts
- Operating Pressure Range: 0 to 300 psig (0 to 20.7 bar)
- Proof Pressure: 375 psig (25.9 bar)
- Burst Pressure: 1250 psig (86.2 bar)
- Media: Air, Inert gases, water, light oils, natural gases
- Media Temperature: -4 to 392°F (-20° to 200°C)
- Ambient Temperature: -4 to 248°F (-20° to 120°C)
- Seal Material: Viton



150BMP-2451B

## 150BMP Solenoid Control Valves

IR Part Number	Thread Size Inlet - Outlet	Voltage (DC)	Weight lb (kg)	Description
150BMP-1051B*	1/4" - 1/4"	12 volt	1.95 (.88)	24" (61 cm) Long wire leads
150BMP-2451B*	1/4" - 1/4"	24 volt	1.95 (.88)	24" (61 cm) Long wire leads
150BMP-6451*	1/4" - 1/4"	64 volt	1.95 (.88)	24" (61 cm) Long wire leads
150BMP-A1051C*	1/4" - 1/4"	12 volt	1.95 (.88)	Pioneer Connector Lead

\* Can be mounted on 150BMP-B2451 elbow bracket.

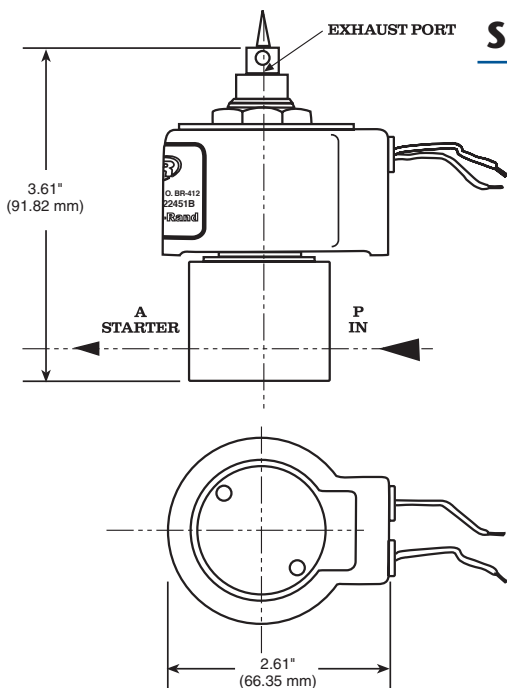

## Solenoid Control Valve & Bracket DIMENSIONS

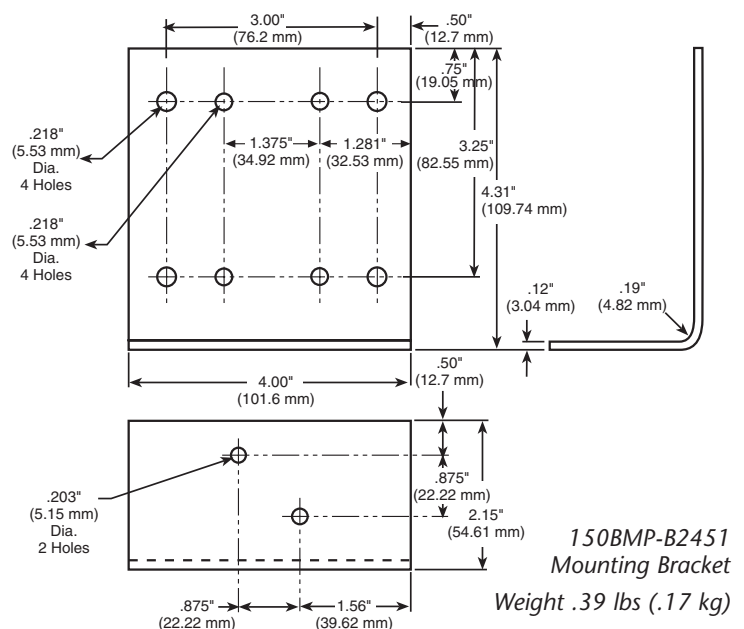

# Solenoid Control Valves

## Specifications

- Rated Operating Pressure: 150 psig
- Rated Operating Voltage: 12-24 VDC
- Rated Current Draw: 750 mA

## ST400 Solenoid Control Valves

IR Part Number	Inlet - Outlet	Weight lb (kg)	Description
ST400-A339M	1" - 1" Flange Style	4.5 (2.04)	Manual Control Valve; must be coupled to Solenoid or Push Button Valve
ST400-C339	1" - 1" Flange Style	2.96 (1.34)	Relay Valve with top mounted Solenoid Valve
ST400-K619	N/A	.30 (.13)	ST400-A339M Repair Kit

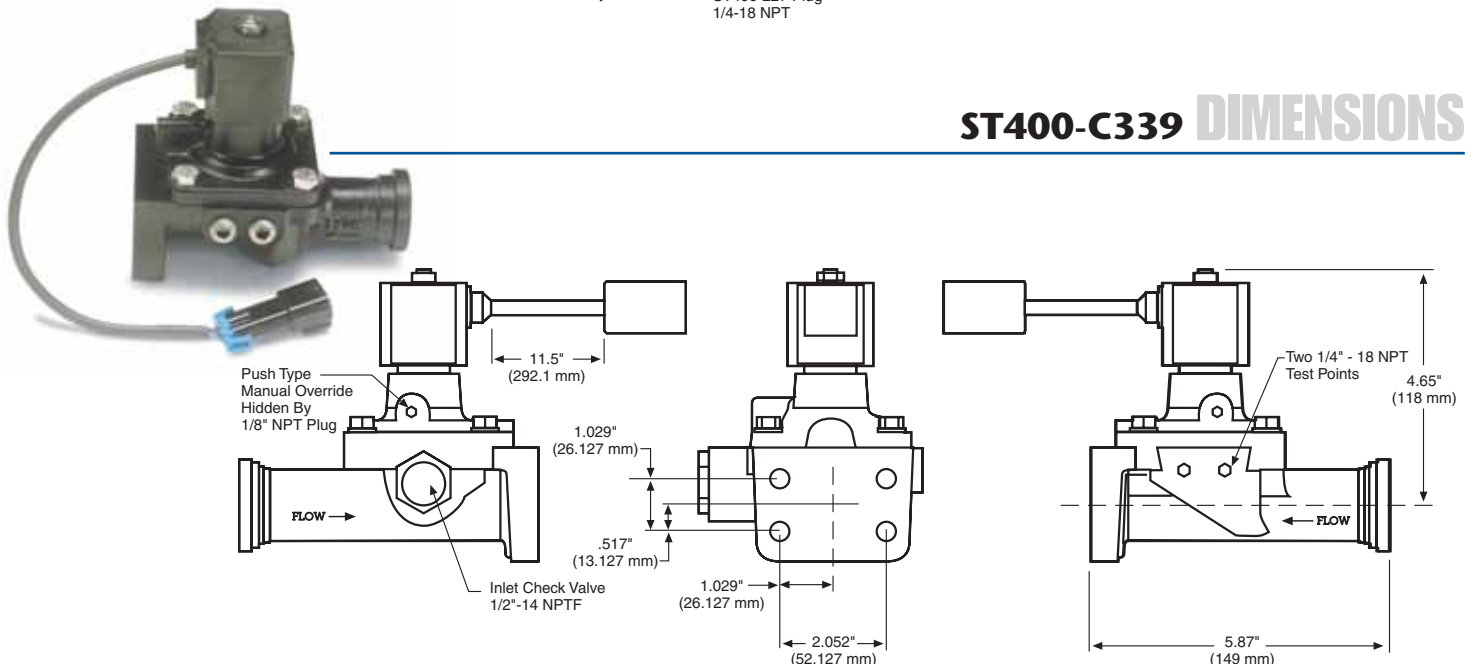
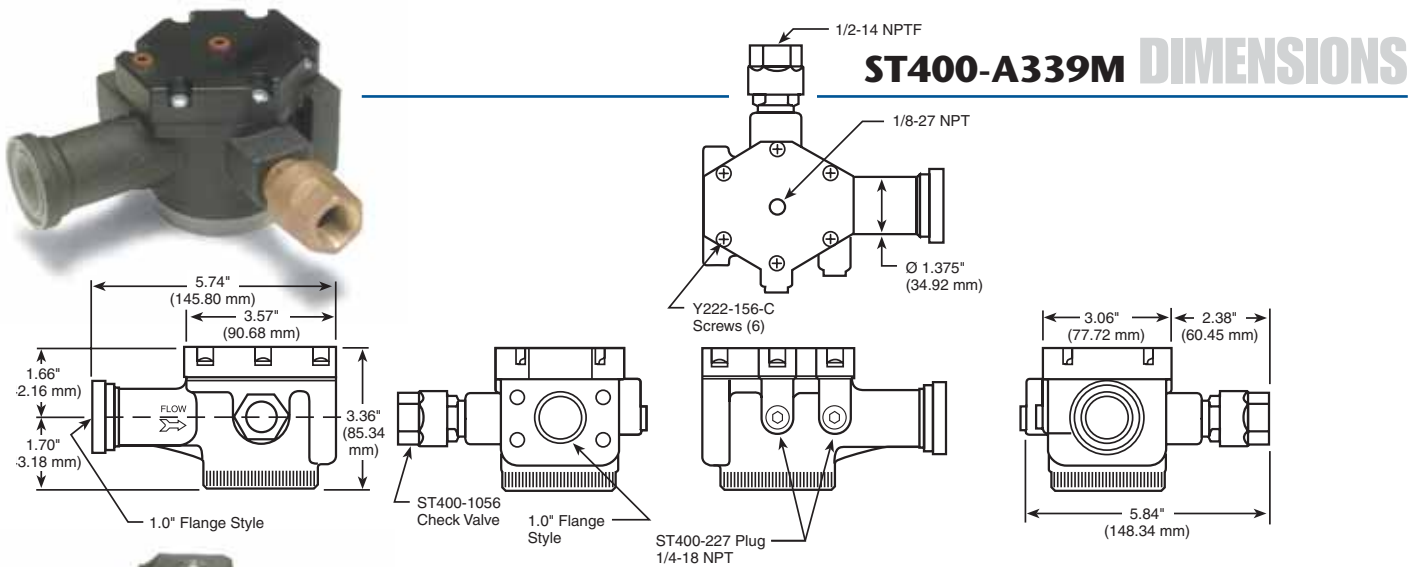

# Push Button Control Valves

The IR manually actuated push button control valve is designed for pilot operation of the IR relay valve. Simple and reliable, this valve readily mounts in a 7/8" diameter hole on dashboards or control panels. The chrome-plated SMB-G618 valve is available for use in marine, offshore, and natural gas applications, while the brass bodies SMB-618 valve is suitable for air applications only.



SMB-618



SMB-G618



SMB-620  
Black Push Button

## Specifications

- Operating Temperature Range: -40 to 200°F (-40 to 93.3°C)
- Maximum Operating Pressure: 225 psi (15.5 bar)

## Push Button Control Valves

IR Part Number	Thread Size Inlet – Outlet	Weight lb (kg)	Description
SMB-618	1/8" – 1/8"	.47 (.21)	Air-approved Push Button Valve
SMB-G618	1/8" – 1/8"	.48 (.21)	Gas-approved Push Button Valve

## Push Button Genuine Ingersoll-Rand Replacement Parts

IR Part Number	Thread Size	Weight lb (kg)	Description
SMB-619	.25" – 28 UNF	.05 (.02)	IR White Push Button
SMB-620	.25" – 28 UNF	.05 (.02)	Black Push Button

## SMB-G618 DIMENSIONS

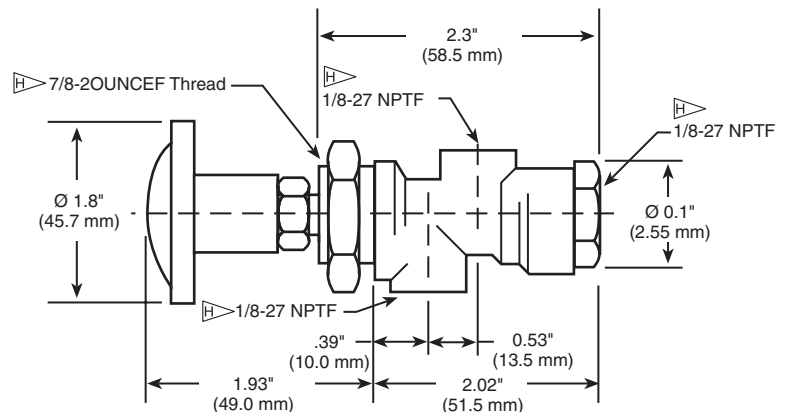

# Air Strainers

IR strainers are used in the air line to assure long starter life where air or gas is contaminated. The strainer screens the starter air utilizing a 300-mesh element reinforced on two sides by a 20-mesh internal stainless steel screen to ensure air integrity.

## Specifications

- Maximum Working Pressure:

Saturated Steam	Water, Oil, Gas	Compressed Air
250 psi @ 400°F	400 psi @ 150°F	500 psi @ 150°F
15.5 bar @ 204°C	27.6 bar @ 66°C	34.4 bar @ 66°C



ST900-267-16  
Air Strainer



ST900-266-16  
Strainer Element

## ST900 Air Strainers

IR Part Number	Thread Size Inlet – Outlet (NPT)	Weight lb (kg)	IR Strainer Element Replacement Part #	Description
ST900-267-16	1" – 1"	3.00 (1.36)	ST900-266-16	3BMG, 5BMG, SS175G Strainer
ST900-267-24	1-1/2" – 1-1/2"	8.00 (3.63)	ST900-266-24	150BM, SS350G, 150T, ST400 Strainer
ST900-267-32	2" – 2"	12.50 (5.67)	ST900-266-32	SS800, ST700, ST900, ST600 Strainer
ST900-267-64	4" – 4"	60 (27.24)	ST900-266-64	SS800, ST700, ST900, ST600 Strainer



# Air Strainers

## Air Strainers DIMENSIONS

IR Part Number	Dim. A in. (mm)	Dim. B in. (mm)	Dim. C in. (mm)
ST900-267-16	4.00 (101.4)	3.25 (82.6)	2.62 (66.5)
ST900-267-24	5.75 (146.1)	5.00 (127.0)	3.87 (98.3)
ST900-267-32	7.00 (177.8)	6.125 (155.6)	4.75 (120.7)
ST900-267-64	13.50 (342.9)	13.00 (330.2)	8.25 (209.6)

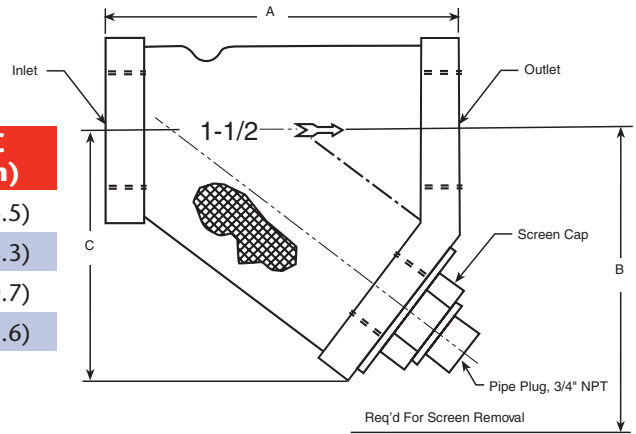

ST900-267-16 (1" Strainer) Pressure Drop at 900 SCFM

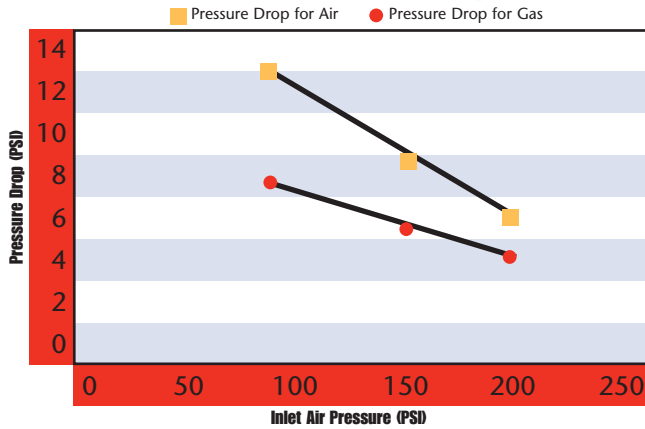

ST900-267-24 (1-1/2" Strainer) Pressure Drop at 1700 SCFM

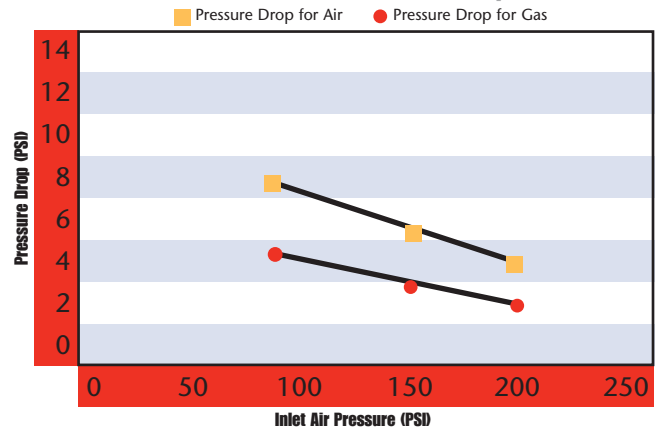

ST900-267-32 (2" Strainer) Pressure Drop at 3400 SCFM

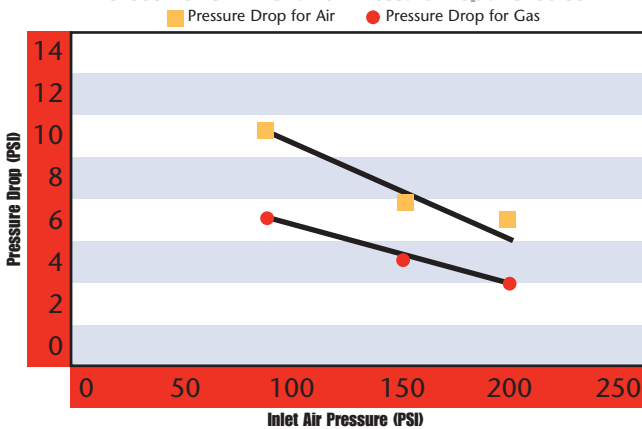

# Mufflers

IR mufflers are designed to effectively limit starting noise levels.

## Features

- Low back pressure provides minimal power loss for full starter power.
- Effective sound attenuation for low noise level.
- Non-freezing for reliable operation.
- Self-cleaning to eliminate clogging and ensure longer life while reducing maintenance time.
- Capable of direct or remote mounting for flexibility of application.

## Muffler DIMENSIONS

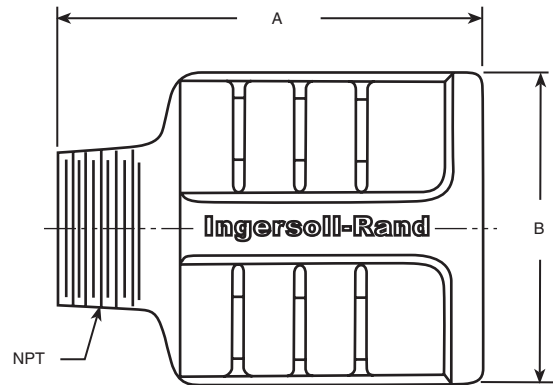

## Specifications

IR Part Number	NPT Size	Dim. A in (mm)	Dim. B in (mm)	Weight lb (kg)	For Model Series
3BM-WM07	3/4"	7.18 (182.37)	2.22 (56.37)	.83 (0.38)	3BM, 5BM (Older Housing)
3BM-A674	1"	8.66 (219.96)	3.85 (97.79)	1.19 (0.54)	3BM, 5BM (New Housing)
150BM-A674	1-1/4"	4.21 (106.9)	3.34 (84.8)	1.50 (0.68)	150BM, SS175
SS350-A674	1-1/2"	4.56 (115.8)	3.31 (84.1)	1.13 (0.50)	SS350
ST500-674	2"	4.82 (122.3)	2.74 (69.6)	1.20 (0.54)	150T, ST500
SS800-A674	2-1/2"	6.66 (169.21)	4.75 (120.77)	3.35 (1.52)	SS800



3BM-WM07



3BM-A674



150BM-A674



SS350-A674



ST500-674



SS800-A674

# Regulators

## Rated Operating Conditions

- Inlet Pressure: 10 to 450 psig (0.7 to 31 bar)
- Maximum Outlet Pressure: 250 psig (17.2 bar)
- Temperature: 0° to 175°F (-18° to 79°C)  
- With dewpoint less than air temperature below 35°F (2°C)
- Air Consumption: 2200 scfm @ 150 psi

## Specifications

- Fluid: Compressed Air
- Type: Standard: Relieving  
Optional: Nonrelieving
- Ports: Main: 1-1/2" or 2" PTF  
Gauge: 1/4" PTF  
Exhaust (Relieving models only): 3/4" PTF
- Outlet Pressure Adjustment Ranges\*:  
Standard: 5 to 125 psig (.3 to 8.6 bar)  
Optional: 2 to 50 psig (.1 to 3.5 bar)  
Optional: 10 to 250 psig (.7 to 17.2 bar)
- Threads: Use SMB-441 sealant on threads of air line fittings. Apply sealant evenly to threads only. Excessive sealant may interfere with valve operation.

\* Outlet pressure adjustment ranges are not minimum or maximum outlet pressure limits. Regulators can be adjusted to zero psig outlet pressure and, generally, to pressures in excess of those specified. The use of these regulators to control pressures outside of the specified ranges is not recommended.



NR-24-8 Pilot Operated Regulator with Integral Pilot

## Regulators

IR Part Number	Description
NR-24-8	Pilot Operated Regulator with Integral Pilot
NR24-TK1	NR-24-8 Tune Up Kit

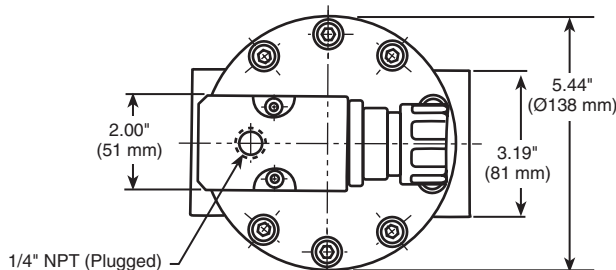

## NR-24-8 DIMENSIONS

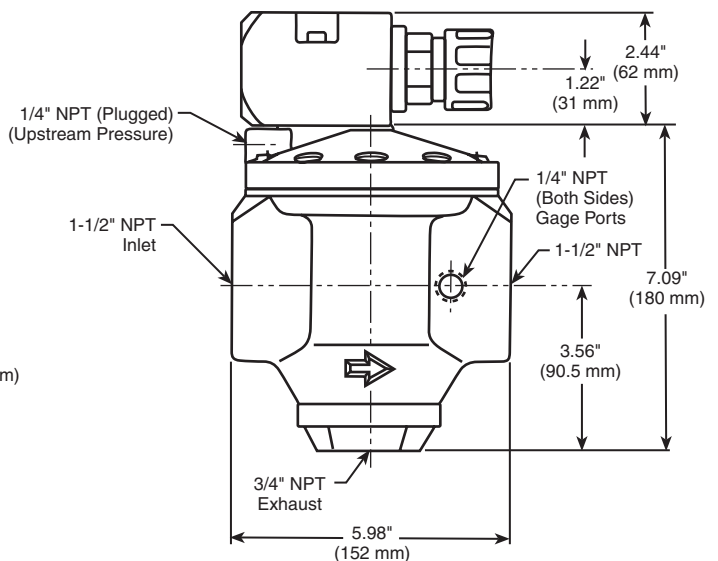

# Regulators

## Pilot Regulator Constant Bleed Feature

The constant bleed feature helps to minimize drop in the outlet pressure when a flow demand is initially placed on the regulator. A very small amount of pilot outlet air continuously escapes to atmosphere. This keeps the pilot valve slightly open to replace the air lost to atmosphere through the constant bleed. Since the valve is always partially open, the pressure drop is minimized when demand is initially increased from no flow to some higher flow. This constant escape of air from the pilot regulator vent is normal and does not indicate a faulty regulator.

## Installation

1. Install a compressed air filter upstream of regulator.
2. In systems with a cyclic demand, install regulator upstream of cycling control valves.
3. System piping should be same size as regulator ports.
4. Install regulator as close as possible to the device being serviced. Regulator can be installed at any angle.
5. Connect piping to proper ports using pipe thread sealant on male threads only. Do not allow sealant to enter interior of regulator. Air flow must be in same direction as arrow on slave regulator body.
6. If desired, connect an outlet pressure gauge to one of the gauge ports. Gauge ports can also be used as additional outlets. Plug unused gauge ports.
7. To reduce noise and protect internal ports, install a muffler (part number M8006A) in the exhaust port (marked "EXH") of relieving type regulators.

## Adjustment

1. Before turning on system pressure, turn pilot regulator adjusting knob counterclockwise until all load is removed from regulating spring.
2. Turn on system pressure.
3. Turn pilot regulator adjusting knob clockwise until the desired outlet pressure is reached.
4. To avoid minor readjustment after making a change in pressure setting, always approach the desired pressure from a lower pressure. When reducing from a higher to a lower setting, first reduce to some pressure less than that desired, then bring up to the desired pressure.
5. Push lockring on adjusting knob downward to lock pressure setting. To release, pull lockring upward.

## Warning

These regulators are intended for use in industrial compressed air systems only. Do not use these regulators where pressure or temperature can exceed rated operating conditions.

If outlet pressure in excess of the regulator pressure setting could cause downstream equipment to rupture or malfunction, install a pressure relief device downstream of the regulator. The relief pressure and flow capacity of the relief device must satisfy system requirements.

The accuracy of the indication of pressure gauges can change, both during shipment (despite care in packaging) and during the service life. If a pressure gauge is to be used with these products and if inaccurate indications may be hazardous to personal property, the gauge should be calibrated before initial installation and at regular intervals during use. For gauge standards refer to ANSI 840, 1-1974.

These products are not designed for use with fluids other than air, for nonindustrial applications, or for life support systems.

## Installation Warning

Do not plug exhaust port in bottom plug of relieving type regulators, as the relief feature will become inoperative.

# In-Line Lubricators

## Specifications

- Reservoir: 1/2 Pint Metal
- Maximum Operating Temperature = 175°F (79°C)
- Maximum Operating Pressure = 250 psi (17.2 bar)
- $C_v = 26$
- Media: Air, Clean natural gas (See Circular Letter A-1077)
- Recommended Operating Flow Range at 100 psig (6.9 bar): 160 to 600 scfm (78 to 283 dm<sup>3</sup>/s)
- Recommended Lubricants: This lubricator will perform satisfactorily using misting type oils rated 150 to 200 SSU (Saybolt seconds) @ 110°F (38°C)
- Material Construction:
  - Body = Aluminum
  - Reservoir = Steel
  - Sight-Feed Dome = Pyrex & Aluminum
  - Elastomers = Neoprene & Buna-N



NL-8-8



NL-24-8

## Installation

- Air line piping should be same size as lubricator ports.
- Install lubricator vertically (sight-feed dome up) in air line downstream of filter and regulator as near as possible to the device being served. This lubricator may be installed upstream or downstream of directional control valves.
- Connect piping to proper ports using pipe thread sealant on male threads only. Do not allow sealant to enter interior of lubricator. Air flow must be in direction of arrow on side of body.
- Remove fill plug and fill reservoir with a good quality lubricant to 3/4" below bottom of threads on dipstick. Do not overfill.

## Adjustment

- Adjust drip rate only when there is a constant rate of flow through the lubricator.
- Determine the average rate of air flow (scfm) through the lubricator, then adjust the needle valve using a 3/32" Allen Wrench to obtain the recommended drip rate (Drops/min). Turn needle valve counterclockwise to increase and clockwise to decrease the drip rate.
- Monitor the device being lubricated for a few days following initial adjustment. Readjust the drip rate if the oil delivery at the device appears either excessive or low.

## Warning

These units must not be used where pressure or temperature may exceed maximum rated operating conditions. See specifications.

In lubrication applications, some oil mist may escape from the point of use into the surrounding atmosphere. Users are referred to OSHA safety and health standards for limiting oil mist contamination and utilization of protecting equipment.

# In-Line Lubricators

## Specifications

IR Part Number	Port Thread Size NPT Inlet – Outlet	Weight lb (kg)
NL-8-8	1/2" – 1/2"	1.70 (.77)
NL-24-8	1-1/2" – 1-1/2"	2.70 (.1.22)
NL24-TK1	N/A	.05 (.02)

### NL-8-8 DIMENSIONS

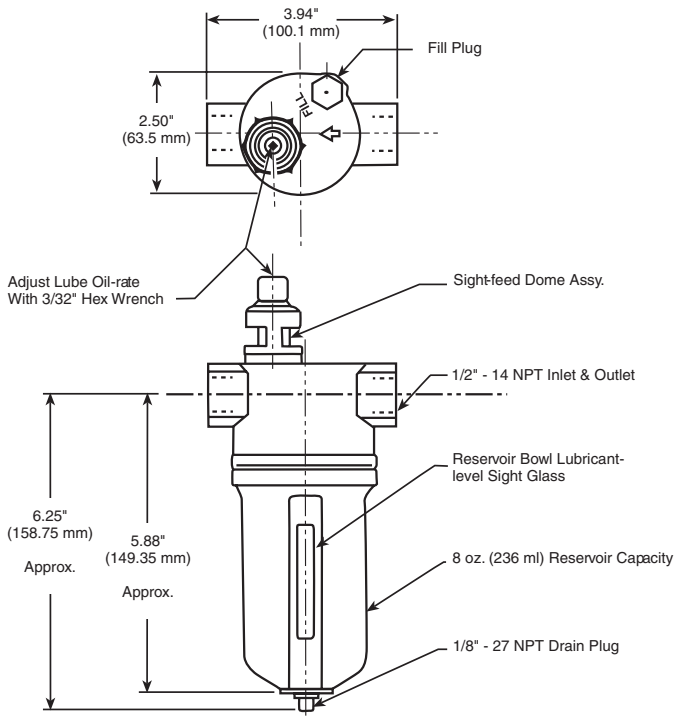

### NL-24-8 DIMENSIONS

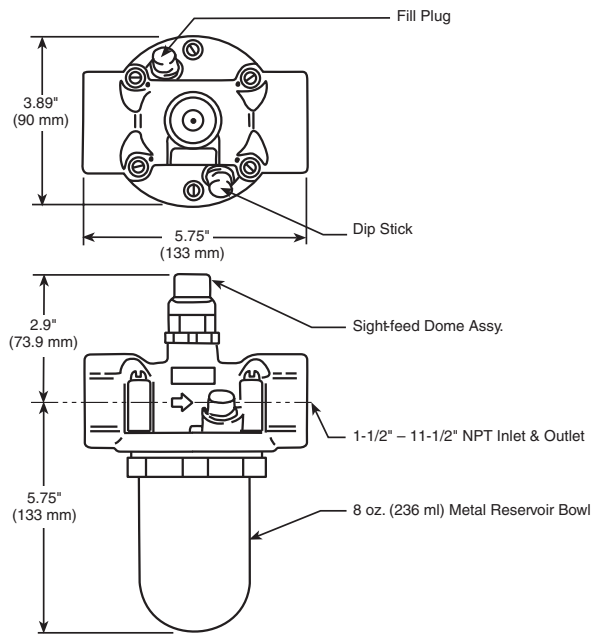

## Recommended Drip Rate

Recommended Drip Rate Settings for Average Lubrication.

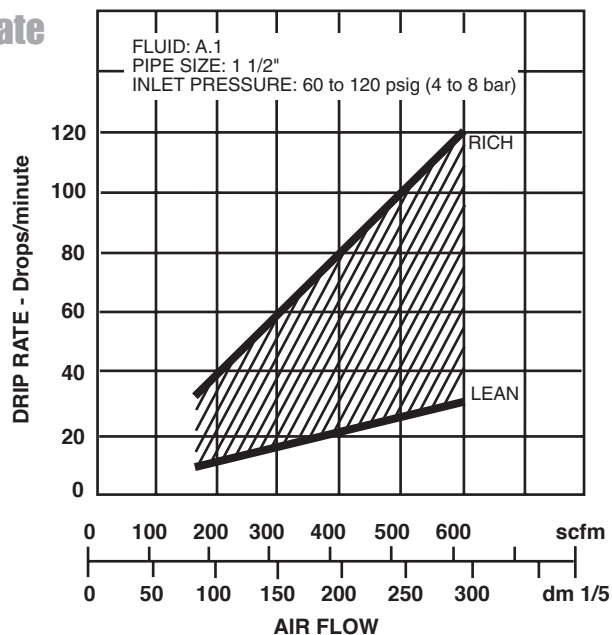

# One-Shot Lubricators

These small, rugged one-shot lubrication devices dispense a controlled amount of lubricant each time the air starter is engaged. Attached directly to the starter, these lubricators are self-priming lubrication pumps, which can draw oil from as far away as 4 feet.

**IR Part Numbers:** HDL2 and HDL3

## Specifications

- Oil inlet must be full of clean oil
- Operating Air Pressure Range: 40 to 250 psi (2.8 to 17.2 bar)
- Operating Temperature: -30°F to 250°F (-34°C to 121°C)
- Operating Lube Pressure: 0-50 psi
- Lubrication Rate: HDL2 = 1.3 cc HDL3 = 0.4 cc
- All-Viton Seals



HDL2

## HDL2/HDL3 DIMENSIONS

IR Part Number	Dim. A in. (mm)	Dim. B in. (mm)
HDL2	2.99 (76)	3.55 (90.2)
HDL3	3.11 (79)	3.67 (93.2)

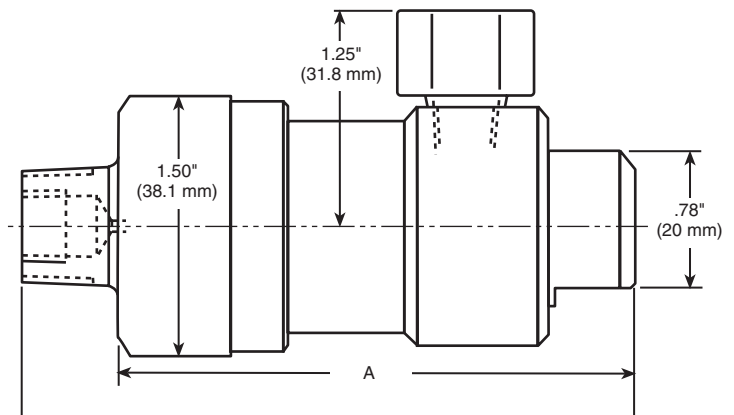

## One-Shot Lubricators Genuine Ingersoll-Rand Replacement Kits

Tune Up Kit Part Number	Description
HDL2-TK1	HDL2 Tune Up Kit
HDL3-TK1	HDL3 Tune Up Kit



HDL2-TK1 Parts



HDL3-TK1 Parts

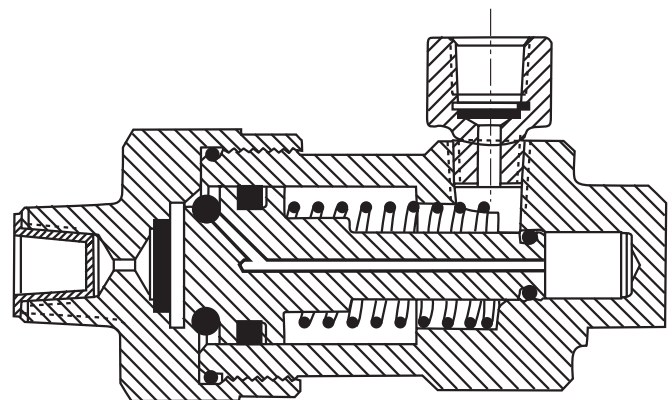

HDL2/HDL3 Cross Section

# Road Splash Deflectors

Constructed of all corrosion-resistant materials, these road splash deflectors are designed to prevent contamination from entering the exhaust port of the starter. Used in applications where a muffler is not required, they allow maximum exhaust air flow for greater starting power and efficiency.

## 150BM-A735 DIMENSIONS

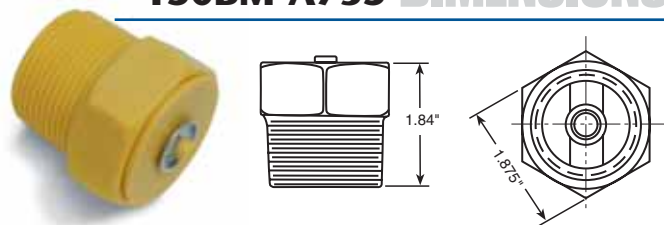

## SS350/ST500/SS800 DIMENSIONS

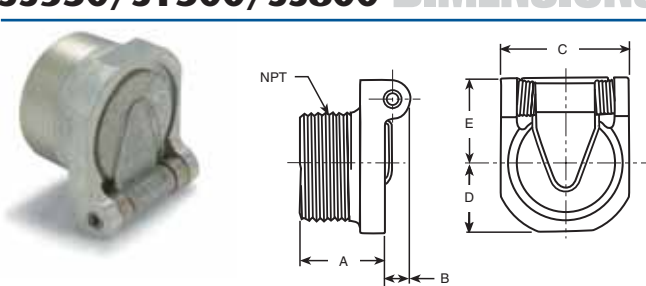

IR Part Number	NPT Size in (mm)	Description	Weight lb (kg)	Dimensions — in (mm)				
				A	B	C	D	E
150BM-A735	1-1/4 (31.75)	150BM Splash Deflector	.12 (0.05)	—	—	—	—	—
SS350-A735	1-1/2" (38.10)	SS350 Splash Deflector	.29 (0.13)	1.40 (35.56)	0.40 (10.16)	2.00 (50.80)	1.00 (25.40)	1.30 (33.02)
ST500-A735	2" (50.80)	150T and ST500 Series Splash Deflector	.45 (0.20)	1.44 (36.50)	0.37 (9.50)	2.63 (66.80)	1.32 (33.60)	1.70 (43.20)
SS800-A735	2-1/2" (63.50)	SS800, SS660, & SM450 Series Splash Deflector	.61 (0.28)	1.90 (48.26)	0.40 (10.16)	3.00 (76.20)	1.50 (38.10)	1.75 (44.45)

# Exhaust Tube Kit

IR Part Number	NPT Size in (mm)	Description
ST500-K740	2" (50.80)	150T & ST500 Duckbill & Clamp



# Liquid Sealant

Liquid sealants should always be used to ensure an air-tight system for air and gas applications.

IR Part Number	Weight lb (kg)	Description
SMB-431	.18 lb (.08 kg)	50 cc "Plastic Gasket" For Gas Sealing
SMB-441	.03 lb (.01 kg)	50 cc Teflon® Sealant For Pipe Threads



© Teflon is a registered trademark of El DuPont de Nemours and Company.



# Check Valves

The 150BMP-1056 is a brass-bodied check valve designed for use in receiver charging systems. It is particularly recommended for vehicular applications. The 150BMP-1054 is a combination check valve/pressure relief valve.

IR Part Number	Thread Size NPT	Weight lb (kg)	Description
150BMP-1056	1/2"	.37 lb (.16 kg)	Check Valve
150BMP-1054	3/4"	.10 lb (.04 kg)	Combination Pressure Relief / Check Valve
ST400-1056	3/4"	.37 lb (.16 kg)	Check Valve with O-Ring

## 150BMP-1056 ST400-1056 DIMENSIONS

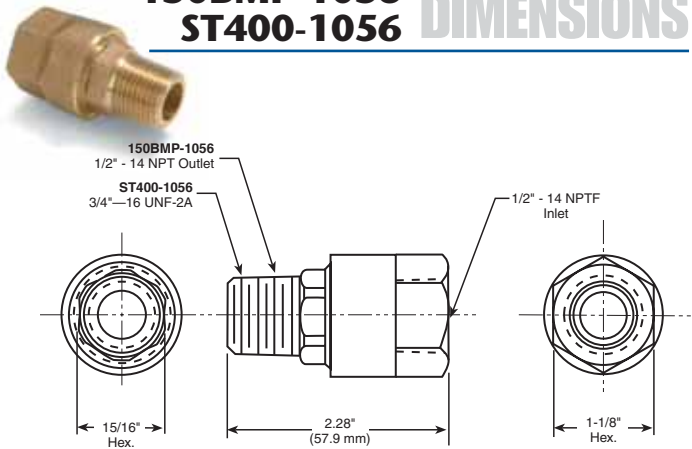

## 150BMP-1054 DIMENSIONS

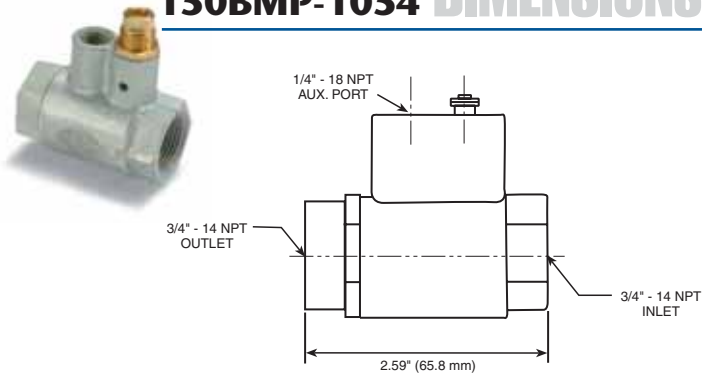

# Drain Valve

Used to keep air supplies clean and free of water and other contaminants.

IR Part Number	Weight lb (kg)	Description
150BMP-1067	.100 lb (.04 kg)	1/2" NPT Connection



## 150BMP-1067 DIMENSIONS

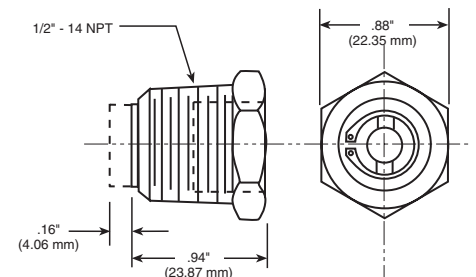

# Gladhand Coupling

Should air pressure ever be lost, the gladhand makes it simple to pump up your system from any nearby truck.

## Specifications

- Maximum Operating Pressure: 150 psi
- Maximum Operating Temperature: 200°F
- Weight: .49 lb (0.22 kg)



150BMP-1058

## 150BMP-1058 DIMENSIONS

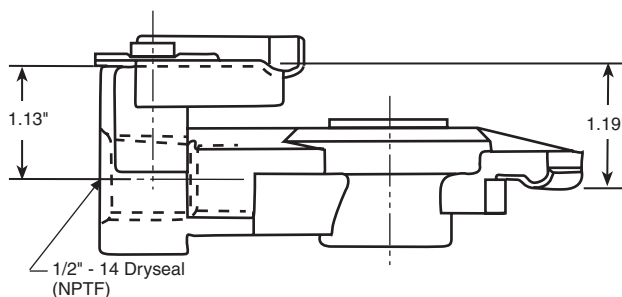
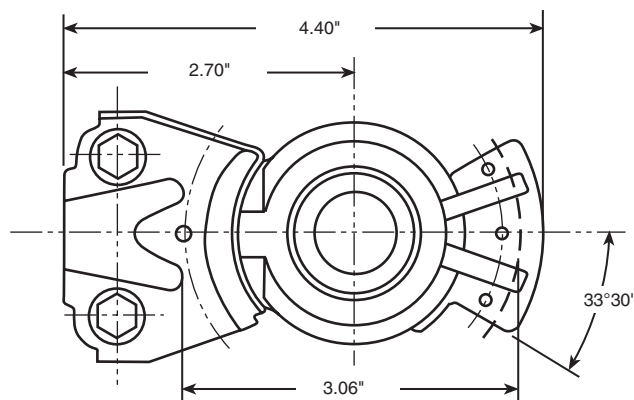

# Pressure Gauges

With a large readout dial, the air pressure gauge assures the user that sufficient air pressure is available for starting before user shuts off engine.



150BMP-1064

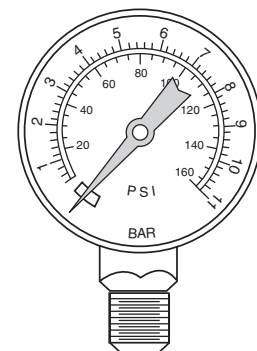

150BMP-1064L

## Specifications

IR Part Number	150BMP-1064	150BMP-1064L	SRV125F-1064
<b>Description</b>	Dash Mount Gauge	Standard Industrial Gauge	Industrial Gauge
<b>Weight - lb (kg)</b>	0.3 (.14)	.16 (.07)	.16 (.07)
<b>Pressure Range (PSI)</b>	0 to 150	0 to 160	0 to 300
<b>Dual Scale Dial</b>	PSI and kPa	PSI and bar	PSI and bar
<b>Diameter Size</b>	2.25" (57.2 mm)	2" (50.8 mm)	2.71" (68.8 mm)
<b>Connection</b>	1/8" NPTF Male Connection on Back	1/4" - 18 NPT Male Connection Centered on Bottom	1/4" - 18 NPT Male Connection Centered on Bottom
<b>Additional Features</b>	5/8" Diameter Lamphole and 2 tighten screws on back	N/A	N/A

**Note:** Accuracy is +/- 2 degrees of full scale